

Complimentary Copy—Not For Sale

OXFORD

New Syllabus

PRIMARY MATHEMATICS

Teacher's
Resource Book



4

Consultant and Author: **Dr Foong Pui Yee**
Authors: **Chang Suo Hui • Brandon Oh**

OXFORD
UNIVERSITY PRESS

CONTENTS

		Scheme of Work	Teaching Notes	Workbook Answers	Problem Solving, Maths Journal and Pupil Review	Lesson Plan	Activity Handbook
Chapter 1	Numbers to 100 000	vi	1				
	1 Counting to 100 000		2	5		6	1 – 5
	2 Comparing and Ordering Numbers		7	9		10	1 – 5
	3 Number Patterns		11	14		15	5 – 7
	4 Rounding Numbers		16 18 20 22	18 20 22		24	
	5 Roman Numerals		25	27	29	28	8
	Review 1			31			
Chapter 2	Multiplication and Division	viii	32				
	1 Factors		33	35		36	
	2 Multiples		37	40		41	9
	3 Multiplying by a 1-Digit Number		42	45		50	10
	4 Multiplying by a 2-Digit Number		46	49		50	
	5 Dividing by a 1-Digit Number		51	55		56	11
	6 Solving Word Problems		57 61	60 62	64	63	12
	Review 2			67			
Chapter 3	Fractions	x	68				
	1 Mixed Numbers		69	72		73	13 – 14
	2 Improper Fractions		74	77		78	15 – 16
	3 Converting Fractions		79	82		88	17 – 18
	4 Comparing and Ordering Fractions		83	87		88	
	5 Fraction of a Set		89	92		93	13
	6 Adding Fractions		94	95		99	13
	7 Subtracting Fractions		96	98		99	13
	8 Solving Word Problems		100	103	104		19 – 23
	Review 3			106			
	Revision 1A			107			
	Revision 1B			108			
Chapter 4	Symmetry	xii	109				
	1 Completing Symmetric Figures		110	112	114	113	24 – 26
	Review 4			116			
Chapter 5	Angles	xiii	117				
	1 Measuring Angles		118	121		125	27
	2 Drawing Angles		122	124		125	
	3 Turns and Right Angles		126	127		128	
	4 8-Point Compass		129	132	134	133	28
	Review 5			136			

		Scheme of Work	Teaching Notes	Workbook Answers	Problem Solving, Maths Journal and Pupil Review	Lesson Plan	Activity Handbook
Chapter 6	Translation and Tessellations	xiv	137				
	1 Translation		138	140		141	29
	2 Recognising Tessellations		142	144	146	145	30 – 31
	Review 6			147			
Chapter 7	Squares and Rectangles	xv	148				
	1 Squares and Rectangles		149	152		153	32 – 33
	2 Drawing Squares and Rectangles		154	160	162	161	34 – 35
	Review 7			164			
	Revision 2A			165			
	Revision 2B			166			
	Mid-Year Revision			167			
Chapter 8	Decimals (I)	xvi	169				
	1 Tenths		170	175		185	36 – 39
	2 Hundredths		176	180		185	37 – 41
	3 Thousandths		181	184		185	37 – 39, 42 – 44
	4 Comparing and Ordering Decimals		186	189		190	37 – 38, 44
	5 Rounding Decimals		191	194		195	
	6 Fractions and Decimals		196	198	200	199	45 – 46
	Review 8			203			
Chapter 9	Decimals (II)	xviii	204				
	1 Adding Decimals		205	208		213	
	2 Subtracting Decimals		209	212		213	47
	3 Multiplying Decimals		214	217		218	
	4 Dividing Decimals		219	225		226	48
	5 Solving Word Problems		227	230	231		49
	Review 9			233			
	Revision 3A			234			
	Revision 3B			235			
Chapter 10	Area and Perimeter	xx	236				
	1 Perimeter of Squares and Rectangles		237	239		240	50
	2 Area of Squares and Rectangles		241	243		244	51 – 53
	3 Area and Perimeter of Composite Figures		245	248		251	54
	4 More on Area and Perimeter		249	250	252	251	
	Review 10			254			
Chapter 11	Tables and Line Graphs	xxii	255				
	1 Tables		256	259		266	
	2 Line Graphs		260	265	267	266	
	Review 11			269			

		Scheme of Work	Teaching Notes	Workbook Answers	Problem Solving, Maths Journal and Pupil Review	Lesson Plan	Activity Handbook
Chapter 12	Time	xxiii	270				
	1 24-Hour Clock		271	273		274	
	2 Duration of Time		275	278		279	
	3 Solving Word Problems		280	282	283		
	Review 12			285			
	Revision 4A			286			
	Revision 4B			287			
	End-of-Year Revision			288			

OXFORD
UNIVERSITY PRESS

CHAPTER 1

Numbers to 100 000

Estimated number of periods: 14

Lesson	Number of Periods	Learning Objectives	Learning Experiences	Textbook Learning	Workbook Practice	Pupil-centred Activities	Concrete Materials
1	3	<p>Counting to 100 000</p> <ul style="list-style-type: none"> Count in ten thousands, thousands, hundreds, tens and ones. 	<ul style="list-style-type: none"> Represent numbers using number discs/placevalue cards and explain place values (e.g. the digit 5 stands for 50 000, 5000, 500, 50 or 5 depending on where it appears in a 5-digit number) Estimate a big number (e.g. the seating capacity of a stadium) 	Textbook 4 P1 – 4	Worksheet 1 Workbook 4A P1 – 6	–	Number discs, place-value chart, place-value cards
2	2	<p>Comparing and Ordering Numbers</p> <ul style="list-style-type: none"> Compare and order numbers within 100 000. 	<ul style="list-style-type: none"> Work in groups using number discs/place-value cards to compare numbers digit by digit from left to right, and use language such as 'greater than', 'greatest', 'smaller than', 'smallest', and 'the same as' to describe the comparison 	Textbook 4 P5 – 7	Worksheet 2 Workbook 3A P3 – 8	–	Number discs, place-value chart, place-value cards
3	2	<p>Number Patterns</p> <ul style="list-style-type: none"> Recognise and complete number patterns. 	<ul style="list-style-type: none"> Use number discs to represent a number that is 10, 100 or 1000 more than/less than a 5-digit number Describe a given number pattern before continuing the pattern or finding the missing number(s) 	Textbook 4 P8 – 12	Worksheet 3 Workbook 3A P9 – 12	Textbook 4 P11	Number discs, mini whiteboard, markers, place-value chart, blank cards, number pattern cards

4	<p>Rounding Numbers</p> <ul style="list-style-type: none"> Round numbers to the nearest 10, 100 or 1000. Estimate the answers in addition and subtraction. 	<ul style="list-style-type: none"> Place a given number on a number line between two consecutive tens/hundreds/thousands and determine which ten/hundred/thousand is nearer to the given number 	<p>Textbook 4 P13 – 15</p> <p>Textbook 4 P16 – 18</p> <p>Textbook 4 P19 – 21</p> <p>Textbook 4 P21 – 22</p>	<p>Worksheet 4A Workbook 4A P13 – 14</p> <p>Worksheet 4B Workbook 4A P15 – 16</p> <p>Worksheet 4C Workbook 4A P17 – 19</p>	<p>–</p> <p>Textbook 4 P18</p> <p>–</p> <p>–</p>	<p>–</p> <p>Markers, mini whiteboard, newspapers</p> <p>–</p> <p>–</p>
5	<p>Roman Numerals</p> <ul style="list-style-type: none"> Understand and write Roman numerals. 	<ul style="list-style-type: none"> Write the numbers represented by the Roman numerals. Write the Roman numerals represented by the numbers. 	<p>Textbook 4 P23 – 25</p>	<p>Worksheet 5 Workbook 4A P20 – 21</p>	<p>–</p> <p>–</p>	<p>Chart paper, scissors, glue, Roman numeral cards</p>
–	<p>Problem Solving, Maths Journal and Pupil Review</p>	<ul style="list-style-type: none"> Estimate real-life living expenses and discuss how the estimation is done 	<p>–</p>	<p>Review 1 Workbook 4A P23 – 26</p>	<p>Textbook 4 P25</p> <p>Workbook 4A P22</p>	<p>–</p>

CHAPTER 2

Multiplication and Division

Estimated number of periods: 28

Lesson	Number of Periods	Learning Objectives	Learning Experiences	Textbook Learning	Workbook Practice	Pupil-centred Activities	Concrete Materials
1	4	<p>Factors</p> <ul style="list-style-type: none"> List all factors of a whole number within 100. Determine if a 1-digit number is a factor of a given number. Identify the common factors of two whole numbers. 	<ul style="list-style-type: none"> Relate the concepts of factor and multiple to multiplication and division Work in groups to express a given number within 100 as a product of two factors and share the different ways of writing the products e.g. $36 = 9 \times 4$ and $36 = 3 \times 12$ 	Textbook 4 P27 – 30	Worksheet 1 Workbook 4A P27 – 30	Textbook 4 P30	Magnetic buttons, dice, markers, mini whiteboard
2	4	<p>Multiples</p> <ul style="list-style-type: none"> List the multiples of a given 1-digit number. Determine if a whole number is a multiple of a given 1-digit number. Identify the common multiples of two 1-digit numbers. 	<ul style="list-style-type: none"> Make a list of the first 12 multiples of a given 1-digit number and use this method to identify the common multiples of two given 1-digit numbers 	Textbook 4 P31 – 35	Worksheet 2 Workbook 4A P31 – 34	Textbook 4 P34	Toothpicks, hundred chart, magnetic buttons, numeral cards
3	4	<p>Multiplying by a 1-Digit Number</p> <ul style="list-style-type: none"> Multiply numbers up to 4-digit by a 1-digit number. 	<ul style="list-style-type: none"> Use number discs to relate to the algorithmic process of multiplication Estimate the answer before doing the calculation to check the reasonableness of calculated answer Work in groups to uncover errors in an algorithm of multiplication 	Textbook 4 P36 – 41	Worksheet 3 Workbook 4A P35 – 48	Textbook 4 P41	Number discs, play money

4	4	<p>Multiplying by a 2-Digit Number</p> <ul style="list-style-type: none"> Multiply numbers up to 3-digit by a 2-digit number. 	<ul style="list-style-type: none"> Use number discs to illustrate and explain the algorithmic process of multiplication by 10 and a multiple of 10 Use mental strategy to multiply numbers up to 3-digit by tens Estimate the answer and use it to check the reasonableness of the calculated answer 	Textbook 4 P42 – 45	Worksheet 4 Workbook 4A P39 – 42	Textbook 4 P45	Number discs, dice
5	4	<p>Dividing by a 1-Digit Number</p> <ul style="list-style-type: none"> Divide numbers up to 4-digit by a 1-digit number. 	<ul style="list-style-type: none"> Use number discs to represent the algorithmic process of division Estimate the answer and use it to check the reasonableness of the calculated answer 	Textbook 4 P46 – 52	Worksheet 5 Workbook 4A P43 – 44	Textbook 4 P52	Number discs, dice, division algorithm template
6	4	<p>Solving Word Problems</p> <ul style="list-style-type: none"> Solve up to 3-step word problems. 	<ul style="list-style-type: none"> Use part-whole and comparison models to represent and solve word problems involving the four operations Work in groups to create 3-step word problems involving the four operations for other groups to solve Solve non-routine problems using different heuristics and share their ideas 	Textbook 4 P53 – 57	Worksheet 6A Workbook 4A P45 – 48	Textbook 4 P56	Markers, mini whiteboard
–	4	<p>Problem Solving, Maths Journal and Pupil Review</p>	<ul style="list-style-type: none"> Apply 'Look for pattern' and 'Make a List' strategies to solve non-routine problems Identify errors in a multiplication and division algorithm 	Textbook 4 P57 – 59	Worksheet 6B Workbook 4A P49 – 50	–	–
–	–				Review 2 Workbook 4A P53 – 58	Textbook 4 P59 – 60 Workbook 4A P51 – 52	

CHAPTER 3

Fractions

Estimated number of periods: 20

Lesson	Number of Periods	Learning Objectives	Learning Experiences	Textbook Learning	Workbook Practice	Pupil-centred Activities	Concrete Materials
1	2	Mixed Numbers <ul style="list-style-type: none"> Write mixed numbers. Simplify mixed numbers. 	<ul style="list-style-type: none"> Use fraction discs/number line to represent fractions greater than one whole as mixed numbers Make connections between common factors and simplifying fraction Give examples of mixed numbers in everyday situations 	Textbook 4 P61 – 66	Worksheet 1 Workbook 4A P59 – 62	Textbook 4 P65	Fraction discs, fraction cards, fraction bars
2	2	Improper Fractions <ul style="list-style-type: none"> Write improper fractions. Simplify improper fractions. 	<ul style="list-style-type: none"> Use fraction discs/number line to represent fractions greater than one whole as improper fractions. Make connections between common factors and simplifying fractions 	Textbook 4 P67 – 72	Worksheet 2 Workbook 4A P63 – 66	Textbook 4 P71	Fraction discs, fraction cards
3	2	Converting Fractions <ul style="list-style-type: none"> Convert between mixed numbers and improper fractions. 	<ul style="list-style-type: none"> Achieve mastery of conversion between mixed numbers and improper fractions by playing games using fraction cards including digital games 	Textbook 4 P73 – 77	Worksheet 3 Workbook 4A P67 – 70	Textbook 4 P76 – 77	Computer (ICT), fraction cards, fraction discs
4	2	Comparing and Ordering Fractions <ul style="list-style-type: none"> Compare and order fractions. 	<ul style="list-style-type: none"> Compare two fractions using fraction discs and then without fraction discs by changing to common denominators 	Textbook 4 P78 – 84	Worksheet 4 Workbook 4A P71 – 74	Textbook 4 P83	Fraction discs, fraction cards

5	4	<p>Fraction of a Set</p> <ul style="list-style-type: none"> Fraction as part of a set of objects. 	<ul style="list-style-type: none"> Divide a given set of concrete objects into equal parts and use this to illustrate the concept of fraction of a set Find a fraction of a set by adding up the objects in the parts Use a pictorial model to represent and find a fraction of a quantity 	Textbook 4 P85 – 89	Worksheet 5 Workbook 4A P75 – 78	Textbook 4 P88	Multilink cubes, fraction discs
6	2	<p>Adding Fractions</p> <ul style="list-style-type: none"> Add two fractions with answers greater than one. 	<ul style="list-style-type: none"> Use fraction discs to illustrate addition of fractions 	Textbook 4 P90 – 91	Worksheet 6 Workbook 4A P79 – 80	–	Fraction discs
7	2	<p>Subtracting Fractions</p> <ul style="list-style-type: none"> Subtract two fractions. 	<ul style="list-style-type: none"> Use fraction discs to illustrate subtraction of fractions 	Textbook 4 P92 – 94	Worksheet 7 Workbook 4A P81 – 82	–	Fraction discs
8	2	<p>Solving Word Problems</p> <ul style="list-style-type: none"> Solve up to 2-step word problems involving addition and subtraction of fractions. 	<ul style="list-style-type: none"> Work in groups to create 2-step word problems involving addition and subtraction of fractions for other groups to solve. 	Textbook 4 P95 – 100	Worksheet 8 Workbook 4A P83 – 86	Textbook 4 P99	Fraction cards, numeral cards, drawing block, markers
–	2	<p>Problem Solving, Maths Journal and Pupil Review</p>	–	–	Review 3 Workbook 4A P87 – 92	Textbook 4 P100 – 101 Workbook 4A P86	–

CHAPTER 4

Symmetry

Estimated number of periods: 6

Lesson	Number of Periods	Learning Objectives	Learning Experiences	Textbook Learning	Workbook Practice	Pupil-centred Activities	Concrete Materials
1	4	Completing Symmetric Figures <ul style="list-style-type: none"> Complete a symmetric figure with respect to a given line of symmetry on square grid. 	–	Textbook 4 P102 – 105	Worksheet 1 Workbook 4A P105 – 106	–	Square grid paper, ruler, pencil, symmetric figure cards, markers
–	2	Problem Solving, Maths Journal and Pupil Review	<ul style="list-style-type: none"> Create symmetric figures with origami paper 	–	Review 4 Workbook 4A P107 – 108	Textbook 4 P106 Workbook 4A P106	Origami paper, scissors, square grid paper

CHAPTER 5

Angles

Estimated number of periods: 12

Lesson	Number of Periods	Learning Objectives	Learning Experiences	Textbook Learning	Workbook Practice	Pupil-centred Activities	Concrete Materials
1	2	Measuring Angles <ul style="list-style-type: none"> Use notation such as $\angle ABC$ and $\angle a$ to name angles. Measure angles in degrees. 	<ul style="list-style-type: none"> Estimate before measuring angles using a protractor 	Textbook 4 P107 – 111	Worksheet 1 Workbook 4A P109 – 110	Textbook 4 P110	Protractor
2	2	Drawing Angles <ul style="list-style-type: none"> Draw angles using a protractor. 	<ul style="list-style-type: none"> Draw angles using a protractor 	Textbook 4 P112 – 114	Worksheet 2 Workbook 4A P111 – 114	–	Protractor, ruler, pencil
3	2	Turns and Right Angles <ul style="list-style-type: none"> Relate quarter, half and complete turns to angles in degrees. 	<ul style="list-style-type: none"> Associate the amount of turn (rotation), clockwise or anticlockwise, with an angle measured in degrees i.e. $\frac{1}{4}$ turn is 90°, $\frac{1}{2}$ turn is 180°, $\frac{3}{4}$ turn is 270° and a complete turn is 360° 	Textbook 4 P115 – 116	Worksheet 3 Workbook 4A P115 – 116	–	Clock
4	4	8-Point Compass <ul style="list-style-type: none"> Find angles (in degrees) between two 8-point compass directions. Use an 8-point compass to name and describe directions. 	<ul style="list-style-type: none"> Find angles (in degrees) between two 8-point compass directions 	Textbook 4 P117 – 122	Worksheet 4 Workbook 4A P117 – 119	–	–
–	2	Problem Solving, Maths Journal and Pupil Review	–	–	Review 5 Workbook 4A P121 – 124	Textbook 4 P123 – 124 Workbook 4A P120	–

CHAPTER 6

Translation and Tessellations

Estimated number of periods: 8

Lesson	Number of Periods	Learning Objectives	Learning Experiences	Textbook Learning	Workbook Practice	Pupil-centred Activities	Concrete Materials
1	2	Translation <ul style="list-style-type: none"> Describe the translation of an object in terms of units. 	<ul style="list-style-type: none"> Describe how an object is moved from its initial position to its final position in terms of translation Draw the shape after translation 	Textbook 4 P125 – 127	Worksheet 1 Workbook 4A P125 – 126	–	Square grid paper, markers, chessboard, chess pieces
2	2	Recognising Tessellations <ul style="list-style-type: none"> Recognise if a pattern is a tessellation Make tessellations using the given shapes 	<ul style="list-style-type: none"> Recognise tessellations Make tessellations using the given shapes 	Textbook 4 P128 – 131	Worksheet 2 Workbook 4A P127	Textbook 4 P130	Shapes for tessellations, scissors, tape, drawing block
–	4	Problem Solving, Maths Journal and Pupil Review	–	–	Review 6 Workbook 4A P129 – 130	Textbook 4 P131 Workbook 4A P128	–

CHAPTER 7

Squares and Rectangles

Estimated number of periods: 10

Lesson	Number of Periods	Learning Objectives	Learning Experiences	Textbook Learning	Workbook Practice	Pupil-centred Activities	Concrete Materials
1	4	Squares and Rectangles <ul style="list-style-type: none"> Recognise the properties of rectangles and squares. 	<ul style="list-style-type: none"> To describe the properties of squares and rectangles in terms of perpendicular and parallel lines To discuss how squares and rectangles are related 	Textbook 4 P132 – 136	Worksheet 1 Workbook 4A P131 – 134	–	Shapes, square grid paper
2	2	Drawing Squares and Rectangles <ul style="list-style-type: none"> Draw rectangles and squares on square grid paper and according to a given dimension using protractor, ruler and set squares. Observe the different orientations of a rectangle when it is rotated. 	<ul style="list-style-type: none"> Work in pairs to explore how to draw different squares and rectangles on square grid Sketch and draw squares and rectangles according to given dimension using ruler, protractor and set squares. Observe the different orientations of a rectangle when it is rotated through 90°, 180°, 270° and 360° clockwise and anticlockwise 	Textbook 4 P137 – 146	Worksheet 2 Workbook 4A P135 – 137	Textbook 4 P138, 145	Set squares, protractor, ruler, square grid paper, play cards
–	4	Problem Solving, Maths Journal and Pupil Review	–	–	Review 7 Workbook 4A P139 – 142	Textbook 4 P146 – 147 Workbook 4A P138	Scissors, glue

CHAPTER 8

Decimals (I)

Estimated number of periods: 24

Lesson	Number of Periods	Learning Objectives	Learning Experiences	Textbook Learning	Workbook Practice	Pupil-centred Activities	Concrete Materials
1		<p>Tenths</p> <ul style="list-style-type: none"> Read and write 1-place decimals. Interpret 1-place decimals in terms of place value. 	<ul style="list-style-type: none"> Use number discs to extend the place-value concept of whole numbers to decimals Count in tenths/hundredths/thousandths using number discs from 0.01 to 1.2, from 0.01 to 0.12, or from 0.001 to 0.012, e.g. 12 tenths is 1.2 	Textbook 4 P148 – 155	Worksheet 1 Workbook 4B P1 – 6	Textbook 4 P154	Number and decimal discs, dice, real-life objects, place-value chart, decimal bars, 1-/ beaker
2	12	<p>Hundredths</p> <ul style="list-style-type: none"> Read and write 2-place decimals. Interpret 2-place decimals in terms of place values. 	<ul style="list-style-type: none"> Recognise that a decimal is made up of a whole-number part and a fractional part, represent the decimal on a number line, and make connections between decimals, fractions and measurement 	Textbook 4 P156 – 162	Worksheet 2 Workbook 4B P7 – 12	Textbook 4 P161	Measuring tape, drawing block, marker, number lines
3		<p>Thousandths</p> <ul style="list-style-type: none"> Read and write 3-place decimals. Interpret 3-place decimals in terms of place values. 	<ul style="list-style-type: none"> Record length/mass/volume of liquid in decimal notation and identify the whole-number parts, tenths, hundredths and thousandths in the decimal Recognise the common usage of decimals in real-life context e.g. shopping and measuring such as person's height and mass 	Textbook 4 P163 – 168	Worksheet 3 Workbook 4B P13 – 16	Textbook 4 P167	Numeral cards, number lines

4	4	<p>Comparing and Ordering Decimals</p> <ul style="list-style-type: none"> Compare and order decimals. 	<ul style="list-style-type: none"> Compare and order two decimals by first comparing the whole number part, and then compare the tenths/hundredths/thousandths Compare and order decimals using number line Use number and decimal discs to represent a number that is 0.1, 0.01 or 0.001 more than/less than a given decimal Create, describe and continue number sequences such as 0.3, 0.6, 0.9, 1.2, ... Look for decimals in every day situation 	Textbook 4 P169 – 174	Worksheet 4 Workbook 4B P17 – 20	Textbook 4 P173	Number and decimal discs, mini whiteboard, numeral cards, place-value chart, number lines
5	4	<p>Rounding Decimals</p> <ul style="list-style-type: none"> Round numbers to the nearest whole number, 1 decimal place and 2 decimal places. 	<ul style="list-style-type: none"> Place a given decimal on a number line between two consecutive whole numbers/tenths/hundredths/thousandths, and determine which is nearer to the given decimal 	Textbook 4 P175 – 180	Worksheet 5 Workbook 4B P21 – 24	Textbook 4 P180	Ruler, measuring tapes, mini whiteboard, markers
6	2	<p>Fractions and Decimals</p> <ul style="list-style-type: none"> Convert fraction to decimal when the denominator of the fraction is a factor of 10 or 100. Convert decimal to fraction. 	–	Textbook 4 P181 – 184	Worksheet 6 Workbook 4B P25 – 27	–	–
–	2	<p>Problem Solving, Maths Journal and Pupil Review</p>	<ul style="list-style-type: none"> Represent equivalent decimals such as 0.8, 0.80 and 0.800 and explain that they are the same number 	–	Review 8 Workbook 4B P29 – 32	Textbook 4 P184 – 185 Workbook 4B P27 – 28	–

CHAPTER 9

Decimals (II)

Estimated number of periods: 30

Lesson	Number of Periods	Learning Objectives	Learning Experiences	Textbook Learning	Workbook Practice	Pupil-centred Activities	Concrete Materials
1		Adding Decimals <ul style="list-style-type: none"> Add decimals of up to 2 decimal places. 	<ul style="list-style-type: none"> Use number and decimal discs to illustrate the addition and subtraction algorithms and make connections between the algorithms for decimals and for whole numbers Use a variety of mental strategies for addition and subtraction and explain the process 	Textbook 4 P186 – 190	Worksheet 1 Workbook 4B P33 – 34	–	Number and decimal discs, place-value chart
2	10	Subtracting Decimals <ul style="list-style-type: none"> Subtract decimals of up to 2 decimal places. 	<ul style="list-style-type: none"> Work in groups on problem solving involving decimals in everyday situations such as food prices in school canteen and budgeting Estimate the answer before doing the calculation and check the reasonableness of calculated answer by comparing it with the estimated answer 	Textbook 4 P191 – 195	Worksheet 2 Workbook 4B P35 – 38	Textbook 4 P195	Markers, number and decimal discs, place-value chart, mini whiteboard, chart paper, decimal addition and subtraction cards

3	<p>Multiplying Decimals</p> <ul style="list-style-type: none"> Multiply decimals (up to 2 decimal places) by a 1-digit whole number. 	<ul style="list-style-type: none"> Use number and decimal discs to illustrate the multiplication and division algorithms and make connections between the algorithms for decimals and for whole numbers 	Textbook 4 P196 – 200	Worksheet 3 Workbook 4B P39 – 42	Textbook 4 P200	Number and decimal discs, dice, mini whiteboard, markers
4	<p>Dividing Decimals</p> <ul style="list-style-type: none"> Divide decimals (up to 2 decimal places) by a 1-digit whole number. <p>12</p>	<ul style="list-style-type: none"> Estimate the product and quotient using multiplication and division within the multiplication tables and use the estimation to check the reasonableness of the calculated answer Divide a whole number by a 1-digit whole number and write the answer as a decimal instead of quotient and remainder 	Textbook 4 P201 – 211	Worksheet 4 Workbook 4B P43 – 48	Textbook 4 P210	Number and decimal discs, mini whiteboard, markers, division algorithm cards
5	<p>Solving Word Problems</p> <ul style="list-style-type: none"> Solve up to 2-step word problems involving the four operations. Round answers to a specified degree of accuracy. <p>6</p>	<ul style="list-style-type: none"> Work in groups to create 2-step word problems based on everyday experiences e.g. using data from supermarket advertisements for other groups to solve 	Textbook 4 P212 – 216	Worksheet 5 Workbook 4B P49 – 53	Textbook 4 P215	Supermarket advertisement, markers, mini whiteboard
–	<p>Problem Solving, Maths Journal and Pupil Review</p> <p>2</p>	–	–	Review 9 Workbook 4B P55 – 60	Textbook 4 P216 – 217 Workbook 4B P54	–

CHAPTER 10

Area and Perimeter

Estimated number of periods: 24

Lesson	Number of Periods	Learning Objectives	Learning Experiences	Textbook Learning	Workbook Practice	Pupil-centred Activities	Concrete Materials
1	4	Perimeter of Squares and Rectangles <ul style="list-style-type: none"> Find the length of a square given its perimeter. Find one dimension of a rectangle given the other dimension and its perimeter. 	<ul style="list-style-type: none"> Apply multiplication and division concepts to find one dimension of a rectangle given its perimeter and other dimension 	Textbook 4 P218 – 221	Worksheet 1 Workbook 4B P75 – 78	–	Rectangles, rope, wire and/or yarn
2	4	Area of Squares and Rectangles <ul style="list-style-type: none"> Find the length of a square given its area. Find one dimension of a rectangle given the other dimension and its area. 	<ul style="list-style-type: none"> Apply multiplication and division concepts to find one dimension of a rectangle given its area and other dimension Draw and cut out squares of different sizes from 4 cm^2 to 100 cm^2 and commit to memory the areas of the squares 	Textbook 4 P222 – 224	Worksheet 2 Workbook 4B P79 – 82	Textbook 4 P223	Square grid paper, scissors, ruler, markers, mini whiteboard, squares and rectangles
3	6	Area and Perimeter of Composite Figures <ul style="list-style-type: none"> Find the area/perimeter of composite figures made up of rectangles and squares. 	<ul style="list-style-type: none"> Make composite figures using cutouts of rectangles and squares and calculate its area and perimeter Visualise how a L-shaped figure can be partitioned into rectangle and squares or can be formed by removing a rectangle/square from a bigger rectangle/square and calculate the area and perimeter of the figure 	Textbook 4 P225 – 230	Worksheet 3 Workbook 4B P83 – 90	Textbook 4 P229	Coloured paper, square grid paper, glue, scissors

4	8	<p>More on Area and Perimeter</p> <ul style="list-style-type: none"> Solve problems related to finding the area and perimeter of a rectangle or square. 	–	Textbook 4 P231 – 232	Worksheet 4 Workbook 4B P91 – 95	–	–
–	2	<p>Problem Solving, Maths Journal and Pupil Review</p>	–		Review 10 Workbook 4B P97 – 100	Textbook 4 P233 Workbook 4B P96	–

OXFORD
UNIVERSITY PRESS

CHAPTER 11

Tables and Line Graphs

Estimated number of periods: 12

Lesson	Number of Periods	Learning Objectives	Learning Experiences	Textbook Learning	Workbook Practice	Pupil-centred Activities	Concrete Materials
1	4	Tables <ul style="list-style-type: none"> Complete a table from given data. Read and interpret data from tables. Solve 1-step problems using data from tables. 	<ul style="list-style-type: none"> Relate the data represented in a table to the corresponding bar graph and explain why the data is presented in a graph instead of table Discuss examples of data presented in bar graphs/ composite bar graphs found in newspapers and magazines and how the data was collected and displayed in graphical form 	Textbook 4 P234 – 239	Worksheet 1 Workbook 4B P101 – 106	Textbook 4 P238	Newspapers or magazines
2	6	Line Graphs <ul style="list-style-type: none"> Read and interpret data from line graphs. Solve 1-step problems using data from line graphs. 	<ul style="list-style-type: none"> Construct a line graph using a spreadsheet (Excel) and make connections between bar and line graphs and explain which type of graph should be used or both can be used Discuss examples of inappropriate representation of data 	Textbook 4 P240 – 249	Worksheet 2 Workbook 4B P107 – 110	Textbook 4 P246	Computer (ICT), chart paper, ruler, markers
–	2	Problem Solving, Maths Journal and Pupil Review	–	–	Review 11 Workbook 4B P 112 – 113	Textbook 4 P250 – 251 Workbook 4B P111	–

CHAPTER 12

Time

Estimated number of periods: 12

Lesson	Number of Periods	Learning Objectives	Learning Experiences	Textbook Learning	Workbook Practice	Pupil-centred Activities	Concrete Materials
1	2	24-Hour Clock <ul style="list-style-type: none"> Tell time in 24-hour clock. 	<ul style="list-style-type: none"> Read and write time in 24-hour clock and give reasons why 24-hour clock is used instead of 12-hour clock 	Textbook 4 P252 – 255	Worksheet 1 Workbook 4B P114 – 115	–	–
2	2	Duration of Time <ul style="list-style-type: none"> Measure time in seconds. 	<ul style="list-style-type: none"> Develop a sense of 10 seconds e.g. what they can do in 10 seconds Describe everyday events using 24-hour clock, including starting time, finishing time and duration 	Textbook 4 P256 – 261	Worksheet 2 Workbook 4B P 116 – 119	Textbook 4 P258	Stopwatch, geared clock
3	6	Solving Word Problems <ul style="list-style-type: none"> Solve word problems involving time in 24-hour clock. 	<ul style="list-style-type: none"> Represent given information such as starting time, finishing time and duration of activity on a timeline and use it to solve problems Work in groups to create word problems involving time in 24-hour clock for other groups to solve 	Textbook 4 P262 – 264	Worksheet 3 Workbook 4B P120 – 123	Textbook 4 P264	Drawing block, markers
–	2	Problem Solving, Maths Journal and Pupil Review	–	–	Review 12 Workbook 4B P124 – 127	Textbook 4 P265 Workbook 4B P123	–

SYLLABUS MATCHING GRID

CAMBRIDGE PRIMARY MATHEMATICS STAGE 4

Learning Objective	Reference
1. Number	
Numbers and the number system	
Recite numbers 100 to 200 and beyond.	Chapter 1
Read and write numbers to at least 1000.	Chapter 1
Count on and back in ones, tens and hundreds from two- and three-digit numbers.	Chapter 1
Count on and back in steps of 2, 3, 4 and 5 to at least 50.	Chapter 1
Understand what each digit represents in three-digit numbers and partition into hundreds, tens and units.	Chapter 1
Find 1, 10, 100 more/less than two- and three-digit numbers.	Chapter 1
Multiply two-digit numbers by 10 and understand the effect.	Book 4 Chapter 2
Round two-digit numbers to the nearest 10 and round three-digit numbers to the nearest 100.	Book 4 Chapter 1
Place a three-digit number on a number line marked off in multiples of 100.	
Place a three-digit number on a number line marked off in multiples of 10.	
Compare three-digit numbers, use < and > signs, and find a number in between.	Book 2 Chapter 1
Order two- and three-digit numbers.	Book 2 Chapter 1
Give a sensible estimate of a number as a range (e.g. 30 to 50) by grouping in tens.	Chapter 1
Find half of odd and even numbers to 40, using notation such as $13\frac{1}{2}$.	Chapter 3
Understand and use fraction notation recognising that fractions are several parts of one whole, e.g. $\frac{3}{4}$ is three quarters and $\frac{2}{3}$ is two thirds.	Chapter 9
Recognise equivalence between $\frac{1}{2}$, $\frac{2}{4}$, $\frac{4}{8}$ and $\frac{5}{10}$ using diagrams.	Chapter 9
Recognise simple mixed fractions, e.g. $1\frac{1}{2}$ and $2\frac{1}{4}$.	Book 4 Chapter 3
Order simple or mixed fractions on a number line, e.g. using the knowledge that comes half way between $\frac{1}{4}$ and $\frac{3}{4}$, and that $1\frac{1}{2}$ comes half way between 1 and 2.	Chapter 9
Begin to relate finding fractions to division.	Book 4 Chapter 3
Find halves, thirds, quarters and tenths of shapes and numbers (whole number answers).	Book 2 Chapter 13
2. Calculation	
Mental strategies	
Know addition and subtraction facts for all numbers to 20.	Chapter 2
Know the following addition and subtraction facts: – multiples of 100 with a total of 1000 – multiples of 5 with a total of 100	Chapter 2
Know multiplication/division facts for $2\times$, $3\times$, $5\times$, and $10\times$ tables.	Book 2 Chapter 3
Begin to know $4\times$ table.	Book 2 Chapter 5
Recognise two- and three-digit multiples of 2, 5 and 10.	Book 2 Chapter 3
Work out quickly the doubles of numbers 1 to 20 and derive the related halves.	Chapter 3
Work out quickly the doubles of multiples of 5 (< 100) and derive the related halves.	Chapter 3
Work out quickly the doubles of multiples of 50 to 500.	Chapter 3

Addition and Subtraction	
Add and subtract 10 and multiples of 10 to and from two- and three-digit numbers.	Book 2 Chapter 2
Add 100 and multiples of 100 to three-digit numbers.	Book 2 Chapter 2
Use the = sign to represent equality, e.g. $75 + 25 = 95 + 5$.	Chapter 2
Add several small numbers.	Chapter 2
Find complements to 100, solving number equations such as $78 + \square = 100$.	
Add and subtract pairs of two-digit numbers.	Chapter 2
Add three-digit and two-digit numbers using notes to support.	Chapter 2
Re-order an addition to help with the calculation, e.g. $41 + 54$, by adding 40 to 54, then 1.	Chapter 2
Add/subtract single-digit numbers to/from three-digit numbers.	Chapter 2
Find 20, 30, ... 90, 100, 200, 300 more/less than three-digit numbers.	Chapter 2
Multiplication and division	
Understand the relationship between halving and doubling.	Chapter 3
Understand the effect of multiplying two-digit numbers by 10.	Chapter 3
Multiply single-digit numbers and divide two-digit numbers by 2, 3, 4, 5, 6, 9 and 10.	Chapter 3
Multiply teens numbers by 3 and 5.	Chapter 3
Begin to divide two-digit numbers just beyond $10\times$ tables, e.g. $60 \div 5$, $33 \div 3$.	Chapter 3
Understand that division can leave a remainder (initially as 'some left over').	Chapter 3
Understand and apply the idea that multiplication is commutative.	Chapter 3
Understand the relationship between multiplication and division and write connected facts.	Chapter 3
3. Geometry	
Shapes and geometric reasoning	
Identify, describe and draw regular and irregular 2D shapes including pentagons, hexagons, octagons and semi-circles.	Book 2 Chapter 11
Classify 2D shapes according to the number of sides, vertices and right angles.	Book 2 Chapter 11
Identify, describe and make 3D shapes including pyramids and prisms; investigate which nets will make a cube.	Book 2 Chapter 12
Classify 3D shapes according to the number and shape of faces, number of vertices and edges.	Book 2 Chapter 12
Draw and complete 2D shapes with reflective symmetry and draw reflections of shapes (mirror line along one side).	Book 2 Chapter 12
Relate 2D shapes and 3D solids to drawings of them.	Book 2 Chapters 11 and 12
Identify 2D and 3D shapes, lines of symmetry and right angles in the environment.	Chapter 11, and Book 2 Chapters 11 and 12
Identify right angles in 2D shapes.	Chapter 11
Position and movement	
Use the language of position, direction and movement, including clockwise and anti-clockwise.	Book 2 Chapter 17
Find and describe the position of a square on a grid of squares where the rows and columns are labelled.	Chapter 12
Use a set square to draw right angles.	Chapter 11
Compare angles with a right angle and recognise that a straight line is equivalent to two right angles.	Chapter 11

4. Measure

Money

Consolidate using money notation.	Chapter 7
Use addition and subtraction facts with a total of 100 to find change.	Chapter 7

Length, mass and capacity

Choose and use appropriate units and equipment to estimate, measure and record measurements.	Chapters 4, 5 and 6
Know the relationship between kilometres and metres, metres and centimetres, kilograms and grams, litres and millilitres.	Chapters 4, 5 and 6
Read to the nearest division or half division, use scales that are numbered or partially numbered.	Chapters 4, 5 and 6
Use a ruler to draw and measure lines to the nearest centimetre.	Chapter 4
Solve word problems involving measures.	Chapters 4, 5 and 6

Time

Suggest and use suitable units to measure time and know the relationships between them (second, minute, hour, day, week, month, year).	Chapter 10
Read the time on analogue and digital clocks, to the nearest 5 minutes on an analogue clock and to the nearest minute on a digital clock.	Chapter 10
Begin to calculate simple time intervals in hours and minutes.	Chapter 10
Read a calendar and calculate time intervals in weeks or days.	

5. Handling data

Organising, categorising and representing data

Answer a real-life question by collecting, organising and interpreting data, e.g. investigating the population of mini-beasts in different environments.	Chapter 8
Use tally charts, frequency tables, pictograms (symbol representing one or two units) and bar charts (intervals labelled in ones or twos).	Chapter 8 and Book 2 Chapter 16
Use Venn or Carroll diagrams to sort data and objects using two criteria.	

6. Problem solving

Using techniques and skills in solving mathematical problems

Choose appropriate mental strategies to carry out calculations.	Chapter 2
Begin to understand everyday systems of measurement in length, weight, capacity and time and use these to make measurements as appropriate.	Chapters 4, 5, 6 and 10
Make sense of and solve word problems, single (all four operations) and two-step (addition and subtraction), and begin to represent them, e.g. with drawings or on a number line.	Chapter 2
Check the results of adding two numbers using subtraction, and several numbers by adding in a different order.	Chapter 2
Check subtraction by adding the answer to the smaller number in the original calculation.	Chapter 2
Check multiplication by reversing the order, e.g. checking that $6 \times 4 = 24$ by doing 4×6 .	Chapter 3
Check a division using multiplication, e.g. check $12 \div 4 = 3$ by doing 4×3 .	Chapter 3
Recognise the relationships between different 2D shapes.	Book 2 Chapter 11
Identify the differences and similarities between different 3D shapes.	Book 2 Chapter 12
Estimate and approximate when calculating, and check working.	Chapter 2
Make a sensible estimate for the answer to a calculation, e.g. using rounding.	Chapter 2
Consider whether an answer is reasonable.	Chapter 2

Using understanding and strategies in solving problems	
Make up a number story to go with a calculation, including in the context of money.	Chapters 2, 3 and 7
Explain a choice of calculation strategy and show how the answer was worked out.	Chapters 2 and 3
Explore and solve number problems and puzzles, e.g. logic problems.	Chapters 1, 2 and 3
Use ordered lists and tables to help to solve problems systematically.	Chapters 1, 2 and 3
Describe and continue patterns which count on or back in steps of 2, 3, 4, 5, 10, or 100.	Chapters 1, 2 and 3
Identify simple relationships between numbers, e.g. each number is three more than the number before it.	Chapters 1, 2 and 3
Identify simple relationships between shapes, e.g. these shapes all have the same number of lines of symmetry.	Chapter 11
Investigate a simple general statement by finding examples which do or do not satisfy it, e.g. when adding 10 to a number, the first digit remains the same.	Chapters 1, 2 and 3
Explain methods and reasoning orally, including initial thoughts about possible answers to a problem.	Chapters 1, 2 and 3

OXFORD
UNIVERSITY PRESS

INTRODUCTION

The Teacher's Resource Book has been designed to promote good teaching practices for teachers to effectively implement the Primary Mathematics Curriculum.

This series provides teachers with the flexibility to choose the elements that are right for their learners. The key focus in Lower Primary Mathematics comprise of the following:

1. pupil-centred learning
2. active participation
3. problem solving
4. critical thinking
5. real-life contextual exercises
6. mathematical communication and reasoning

Teachers must provide a conducive environment for learning Mathematics in the classroom that encourages creativity and enjoyment. When introducing a concept to pupils, teachers need to ensure that pupils are able to relate mathematical activities and problems to relevant and real-life situations. Teaching mathematical concepts in real-life contexts and providing hands-on experience assist pupils to understand the concepts. Therefore, teachers need to provide mathematical contexts that are relevant to the pupils. Pupils need to apply the concepts and skills in various areas of Mathematics to find solutions to problems involving real-life situations. This series engages the pupils to learn by the Concrete-Pictorial-Abstract (C-P-A) approach:

Exploring concepts using **concrete** materials, leading to the use of **pictorial** representations and then, the **abstract**. Using this approach, pupils are first introduced to a concept through real-life examples or hands-on activities. The exercises then progress with the help of pictorial representations. Once they have a good understanding of the concept, mathematical notation; symbols and computations are introduced to achieve mastery in the abstract.

The Teacher's Resource Book provides instructions on the use of resources to help them carry out the abovementioned objectives. If a concept is taught in a comprehensive manner with clear instructions supplemented with hands-on activities and practice, most pupils would be able to achieve the set assessment target. Each pupil has a set pattern and pace of grasping concepts, but the expectation is the plateau of mathematical competency for all. In this regard, the Teacher's Resource Book serves as a support to teachers using this series.

The five main strands of the Primary Mathematics Curriculum are:

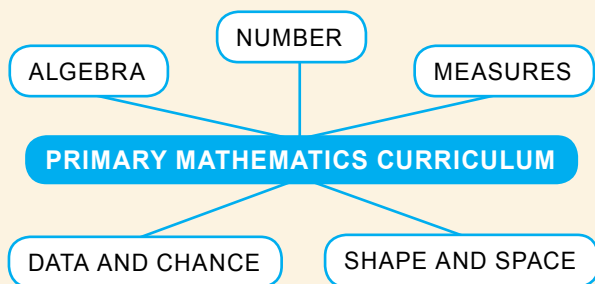

The Teacher's Resource Book supports a meaningful and holistic approach to teaching the strands of Mathematics. The buildup of concepts throughout this series is progressive and comprehensive.

With the implementation of hands-on activities, the learning of a mathematical concept is complemented with experiences that make learning Mathematics enjoyable and give pupils the ownership of independent and group practices. Multiple strategies are implemented through activities in the form of games, model work, standard and non-standard materials and resources. The Teacher's Resource Book facilitates teachers to implement this aspect of the series proficiently. The Teacher's Resource Book provides a structure whereby teachers and coordinators can select, combine and improvise various pedagogical practices for the pupil-centric textbook and workbooks.

In this regard, the Teacher's Resource Book provides the following elements:

- **Scheme of Work** - A tabulated guide showing a breakdown of each lesson's learning objectives, learning experiences, page references of relevant resources, concrete materials required and suggested number of periods required to conduct the lesson, keeping in mind the level of difficulty of the content.
- **Syllabus Matching Grid** - A tabulated guide referring the chapters in this series to the learning objectives of the Cambridge Primary Mathematics curriculum.
- **Exposition of Lessons** - A guide for teachers to prepare and conduct lessons.
- **Answers** - Solutions to questions in the textbook and workbook are provided, along with detailed steps where required.
- **Activities** - Additional activities to assist teachers to support struggling learners and challenge advanced learners.
- **Lesson Plans** - Detailed lesson plans for the lessons to formalise the teaching approach for the teachers. It encompasses prior learning, pre-emptive pitfalls, introduction, problem solving and mathematical communication support.
- **Navigating through the Assessment Activities and Exercises** - An essay explaining to teachers how to use the resources provided effectively when conducting the lessons. The resources include formative and progressive exercises, activities and assessments provided in the textbook and workbook.
- **Activity Handbook** - Activity templates and worksheets for pupils to use when carrying out activities and to supplement the lessons.

NUMBERS TO 100 000

CHAPTER

1

Numbers to 100 000 CHAPTER 1



How can you estimate the number of people that can be seated in a stadium?

COUNTING TO 100 000 LESSON 1

RECAP



Thousands	Hundreds	Tens	Ones
6	4	3	5

$6435 = 6 \text{ thousands } 4 \text{ hundreds } 3 \text{ tens } 5 \text{ ones}$
 $6435 = 6000 + 400 + 30 + 5$
We write 6435 as six thousand, four hundred and thirty-five.

1 CHAPTER 1 OXFORD UNIVERSITY PRESS

Textbook 4 P1

Related Resources

NSPM Textbook 4 (P1 – 26)
NSPM Workbook 4A (P1 – 26)

Materials

Number discs, place-value cards, place-value chart, blank cards, markers, mini whiteboard, number pattern cards, newspapers, chart paper, scissors, glue, roman numeral cards

Lesson

Lesson 1 Counting to 100 000
Lesson 2 Comparing and Ordering Numbers
Lesson 3 Number Patterns
Lesson 4 Rounding Numbers
Lesson 5 Roman Numerals
Problem Solving, Maths Journal and Pupil Review

INTRODUCTION

In Grade Three, pupils have learnt to read and write 4-digit numbers and to interpret the place values of each digit. The learning experiences in this chapter will extend the number system to 5-digit numbers with the use of number cards and place-value cards. Mastery of place-value concept will facilitate their understanding of the four operations algorithms in the later chapters. Pupils will be introduced to the concept of rounding numbers, a pre-requisite for estimating answers.

To make sense of big numbers (up to 100 000), pupils could be asked to find real-life examples of such numbers. Pupils could also be given the opportunity to use number discs/number line to compare numbers.

LESSON

1

COUNTING TO 100 000

LEARNING OBJECTIVE

- Count in ten thousands, thousands, hundreds, tens and ones.

Numbers to 100 000

CHAPTER

1



How can you estimate the number of people that can be seated in a stadium?

COUNTING TO 100 000

RECAP

1000 1000

1000 1000

1000 1000

100 100

100 100

10 10

10

1 1

1 1

1

Thousands	Hundreds	Tens	Ones
6	4	3	5

LESSON

1

6435 = 6 thousands 4 hundreds 3 tens 5 ones
 6435 = 6000 + 400 + 30 + 5
 We write 6435 as **six thousand, four hundred and thirty-five**.

1 CHAPTER 1

OXFORD UNIVERSITY PRESS

RECAP

To recap, elicit responses to read the number. Then ask pupils to write the number in words on their mini whiteboards.

Allow pupils to work in groups to represent the number using number discs, noting in particular the number of thousands, hundreds, tens and ones in the number.

Ask the pupils the following questions:

- What does the digit __ stand for?
- Which digit is in the thousands place?
- What is the value of the digit __?

Repeat with another 4-digit number.



How many people attended a soccer match at the stadium?

LET'S LEARN

1. 43 567 people attended a soccer match at the stadium.



Ten Thousands	Thousands	Hundreds	Tens	Ones
4	3	5	6	7

$$\begin{aligned}
 43\ 567 &= 4 \text{ ten thousands } 3 \text{ thousands } 5 \text{ hundreds } 6 \text{ tens } 7 \text{ ones} \\
 &= 40\ 000 + 3\ 000 + 500 + 60 + 7 \\
 &= 43\ 000 + 567
 \end{aligned}$$

The digit 4 is in the **ten thousands** place. It stands for 40 thousands or 40 000.
 The digit 3 is in the **thousands** place. It stands for 3 thousands or 3000.
 The digit 5 is in the **hundreds** place. It stands for 5 hundreds or 500.
 The digit 6 is in the **tens** place. It stands for 6 tens or 60.
 The digit 7 is in the **ones** place. It stands for 7 ones or 7.

10 000 = 10 thousands



Textbook 4 P2

Use the Chapter Opener (P1) to discuss how they can estimate the number of people that can fill the entire stadium. Prompt the pupils with these questions:

- Who has been inside the stadium?
 - What do you notice about the seating arrangement?
- Allow pupils to work in groups to think about ways to estimate the number of seats. Give hints:
- Estimate the number of seats in each block and count the number of blocks.

Invite the groups to record their estimates on the board.

LET'S LEARN

Write 43 567 on the board. Ask pupils:

- How many digits are there in this number?
- How do we read this number?

Teacher reads the number aloud and writes:

Forty-three thousand, five hundred and sixty-seven

Guide the pupils to read the number aloud pointing to the numerals. Tell the pupils that when writing a 5-digit number, we leave a gap between the thousand and hundred digit.

Show pupils the 'ten thousands' number disc. Work with pupils to use the appropriate number discs to represent the number and fill in the place-value chart. Reinforce the place-value concept for each digit by asking:

- What does the digit ___ stand for?
- Which digit is in the ___ place?
- What is the value of the digit ___?

Next, use place-value cards to represent 43 567. Use individual cards to show the value of each digit.

Show how 43 567 can be written in words by starting from the ten thousands place, then going on to the thousands place, the hundreds place, the tens place and finally the ones place.

For Let's Learn 2, use number discs and place-value cards to guide pupils to fill in the blanks.

We can also use place-value cards to show the number.

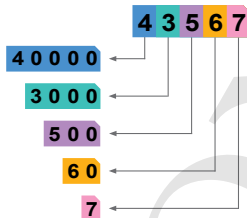

The value of the digit 4 is 40 000.
 The value of the digit 3 is 3000.
 The value of the digit 5 is 500.
 The value of the digit 6 is 60.
 The value of the digit 7 is 7.
 We write 43 567 as **forty-three thousand, five hundred and sixty-seven**.

2. Show 14 359 using and .

Ten Thousands	Thousands	Hundreds	Tens	Ones
1	4	3	5	9

14 359 = 1 ten thousand 4 thousands 3 hundreds 5 tens 9 ones

$$\begin{aligned}
 14\ 359 &= (1 \times 10\ 000) + (4 \times 1\ 000) + (3 \times 100) + (5 \times 10) + (9 \times 1) \\
 &= 10\ 000 + 4\ 000 + 300 + 50 + 9
 \end{aligned}$$

How do you write this number in words?

Fourteen thousand, three hundred and fifty-nine

Textbook 4 P3

3. What is the number represented by the set of number discs? Write the number in numerals and in words.



54 336; Fifty-four thousand, three hundred and thirty-six

4. What does the digit 5 stand for in each of the following numbers?

- (a) 50 789 50 000
 (b) 15 032 5000
 (c) 43 657 50



PRACTICE

1. Write in numerals.
 (a) Fifty-five thousand, three hundred and fifteen 55 315
 (b) Twenty thousand and six 20 006
2. Write in words.
 (a) 25 612 Twenty-five thousand, six hundred and twelve
 (b) 68 001 Sixty-eight thousand and one
3. In 43 815.
 (a) The digit 3 is in the thousands place.
 (b) The digit 1 has a value of 10.
 (c) The digit 4 stands for 40 000

Complete Workbook 4A, Worksheet 1 • Pages 1–6

OXFORD
UNIVERSITY PRESS

NUMBERS TO 100 000

4

Textbook 4 P4

For Let's Learn 3, allow pupils to work in pairs to read and write the the number in words and in numerals.

For Let's Learn 4, allow pupils to work in pairs using number discs and place-value cards to find the answers.

PRACTICE



Work with pupils on the practice questions.

For better understanding, select items from **Worksheet 1** and work these out with the pupils

Independent seatwork

Assign pupils to complete Worksheet 1 (Workbook 4A P1 – 6).

1. (a)

Ten Thousands	Thousands	Hundreds	Tens	Ones
6	3	2	9	4

The number is 63 294.

(b)

Ten Thousands	Thousands	Hundreds	Tens	Ones
7	0	9	0	1

The number is 70 901.

(c)

Ten Thousands	Thousands	Hundreds	Tens	Ones
2	4	0	7	8

The number is 24 078.

(d)

Ten Thousands	Thousands	Hundreds	Tens	Ones
3	0	0	9	0

The number is 30 090.

2. (a) 19 872
 (b) 26 518
 (c) 79 421
 (d) 50 720

3. (a) Twelve thousand, nine hundred and forty-two
 (b) Thirty-seven thousand, eight hundred and fifty-one
 (c) Sixty thousand and fourteen
 (d) Twenty thousand and five

4. (a) 80 000
 (b) 3000
 (c) 67 527
 (d) 30 904
 (e) 54 032
 (f) 68 000

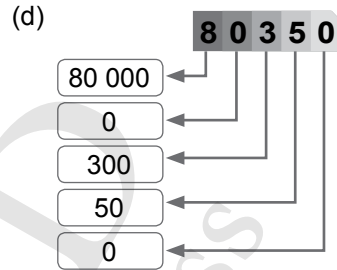
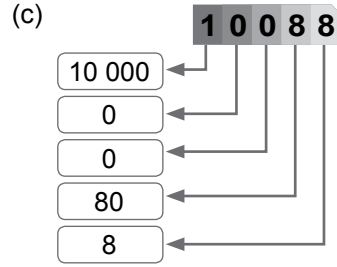
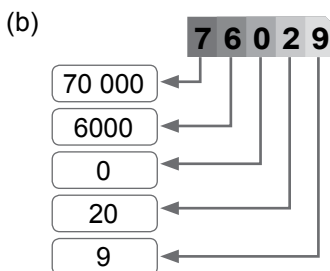
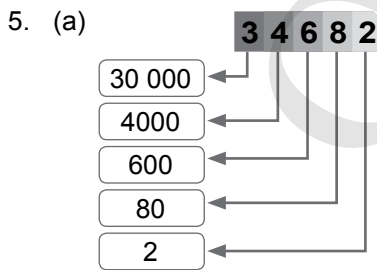

6. (a) 300
 (b) 50 000
 (c) 6
 (d) 8
 (e) 5

*7. 51 009

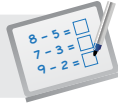
**Specific Learning Focus**

- Count in ten thousands, thousands, hundreds, tens and ones.

Suggested Duration

3 periods

Prior Learning

Pupils should have grasped the place-value concept in 4-digit numbers and the application of the four operations on 4-digit numbers in the earlier grade. This chapter extends their learning experience to 5-digit numbers, where pupils move on from learning place-value concept in 4-digit numbers to 5-digit numbers.

Pre-emptive Pitfalls

Some pupils might find working with 5-digit numbers challenging, especially when they are required to write in expanded form, a number with the digit '0' in one or more of the places in a 5-digit number.

Introduction

Verbalise the 'Recap' (Textbook 4 P1) to the pupils and give a real-life example of a 5-digit number – the number of spectators in a stadium or the number of audience at a concert. The teacher may also mention a match that has recently taken place in the country. Using number discs, elicit individual responses for the expanded form of the number 6435. Recapitulate with pupils the spelling of 6435 in words, on the board. Introduce the ten thousand place value as the value of the first digit on the left of a 5-digit number. Emphasise that when we write a 5-digit number in numerals, a gap is left between the digit in the hundreds place and the digit in the thousands place. Show how 43 567 can be written in expanded form with the help of a place-value chart. Use number discs and place-value cards while going through the questions in 'Let's Learn' and 'Practice' in class.

Problem Solving

When introducing a 5-digit number, take the pupils to the school auditorium and talk about the estimated number of seats, which would be in hundreds. Then ask them to guess the number of the rows and number of seats in each row in a stadium during a recent match or the number of audience at a recent concert. Show the estimation on the board or ask individual groups to present on the board the strategy used to estimate the number.

Activities

Get pupils to work in groups to answer the questions in 'Let's Learn' and 'Practice' using number discs and place-value cards.

Resources

- number discs (Activity Handbook 4 P5)
- place-value chart (Activity Handbook 4 P1)
- place-value cards (Activity Handbook 4 P2 – 4)

Mathematical Communication Support

Write a 5-digit number on the board, preferably with the digit '0' in one or more places (e.g. 45 064), and elicit individual responses for the expanded form of the number. Emphasise to pupils that there are zero hundreds in 45 064. Ask for real-life scenarios where 5-digit numbers are used (e.g. total number of days in 50 years, population of a town, amount written on a cheque). Encourage pupils to do research to find more real-life scenarios. If pupils have a good understanding of the application of 5-digit numbers in real life, the teacher may introduce figures related to the economy of the country (e.g. the total number of sales of Toyota cars).

COMPARING AND ORDERING NUMBERS

LEARNING OBJECTIVE

1. Compare and order numbers within 100 000.

COMPARING AND ORDERING NUMBERS

LESSON
2

RECAP

Arrange 3621, 6321 and 3216 in order. Start with the greatest.

Show the numbers using .

Thousands	Hundreds	Tens	Ones
3	6	2	1
Thousands	Hundreds	Tens	Ones
6	3	2	1
Thousands	Hundreds	Tens	Ones
3	2	1	6



6 thousands is greater than 3 thousands.
6321 is the greatest.
6 hundreds is greater than 2 hundreds.
3621 is greater than 3216.

6321, 3621, 3216
greatest → smallest

IN FOCUS

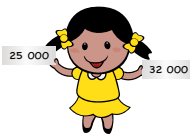

Which number is greater?

5 CHAPTER 1

OXFORD UNIVERSITY PRESS

Textbook 4 P5

RECAP

When reviewing the comparison of 4-digit numbers, ask the following questions:

- What should we compare first, the thousands, the hundreds, the tens or the ones?
- What should we do next if the digit in the thousands place is the same?

Remind pupils to start comparing from the largest place value.

IN FOCUS

Ask pupils to read aloud the two numbers held by the girl.

Ask them how they can use the strategy for comparing 4-digit numbers to compare 5-digit numbers.

LET'S LEARN

1. Compare 25 000 and 32 000.

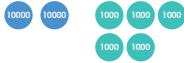

Ten Thousands	Thousands	Hundreds	Tens	Ones
2	5	0	0	0



Ten Thousands	Thousands	Hundreds	Tens	Ones
3	2	0	0	0

3 ten thousands is greater than 2 ten thousands.
32 000 is greater than 25 000.
We can also compare using a **number line**.

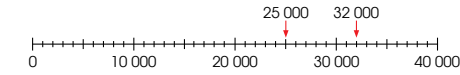

32 000 is greater than 25 000.

2. Which number is smaller, 63 398 or 62 431?



Both numbers have the same digit in the **ten thousands** place.
We compare the digit in the **thousands** place.

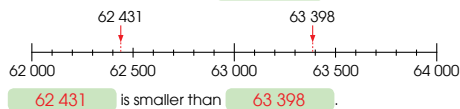

62 431 is smaller than 63 398.

OXFORD UNIVERSITY PRESS

NUMBERS TO 100 000 6

Textbook 4 P6

LET'S LEARN

With the aid of a visualiser, represent the two numbers using number discs. Ask a pupil to fill up the place-value chart on the board.

Ask the class which place value they should compare first.

Highlight to the class that 3 ten thousands is greater than 2 ten thousands. So 32 000 is greater than 25 000. Ask the class:

- Is there another way to compare and order the numbers?

Display the number line using the visualiser. Ask the class where 25 000 and 32 000 should be placed on the number line. Ask the pupils:

- Does the number line show the order of the two numbers? Why?

For Let's Learn 2, guide pupils to compare the numbers using place-value cards. Then illustrate the number lines to check the answers.

3. Compare the numbers 70 070, 77 007 and 70 770.

Arrange the numbers in decreasing order.
Use or a number line to compare.

77 007 is the greatest

70 070 is the smallest

77 007, 70 770, 70 070

'Decreasing' means from the greatest to the smallest.



4. Arrange the numbers in increasing order.

Use or a number line to compare.

67 431, 54 213, 51 234, 32 421

32 421, 51 234, 54 213, 67 431

'Increasing' means from the smallest to the greatest.



PRACTICE



PRACTICE



For Let's Learn 3 and 4, working in groups, pupils can use the place-value chart or number line to compare the numbers. Ask them to discuss the strategies for comparing and ordering the numbers. Hints:

- Find the smallest and the greatest number first.

Work with pupils on the practice questions.

For better understanding, select items from **Worksheet 2** and work these out with the pupils.

Independent seatwork

Assign pupils to complete Worksheet 2 (Workbook 4A P7 – 10).

1. Compare the numbers.

(a) **78 546** **78 000**

78 546 is **546** more than 78 000.

78 546 is greater than 78 000

(b) **39 802** **38 920**

38 920 is smaller than 39 802

(c) **40 044** **44 400** **40 440**

44 400 is the greatest.

40 044 is the smallest.

2. Arrange the numbers in decreasing order.

(a) 41 634, 46 214, 45 201 (b) 67 453, 76 452, 66 789, 78 921

46 214, 45 201, 41 634 78 921, 76 452, 67 453, 66 789

3. Arrange the numbers in increasing order.

(a) 10 540, 10 054, 10 450 (b) 65 666, 65 566, 66 566, 66 656

10 054, 10 450, 10 540 65 566, 65 666, 66 566, 66 656

Complete Workbook 4A, Worksheet 2 • Pages 7 – 10

7 CHAPTER 1

OXFORD UNIVERSITY PRESS

Textbook 4 P7

1. (a) 4589
(b) 9889

2. (a) 9523
(b) 8360

3. 2376, 2673, 3627, 3762

4. 9430, 9034, 3904, 2490

5. (a) 29 898
(b) 30 207
(c) 19 567
(d) 73 669

6. (a) 56 795
(b) 83 515
(c) 40 320
(d) 59 826

7. (a) 48 304
(b) 21 543
(c) 29 310
(d) 12 975

8. (a) 24 300
(b) 67 115
(c) 47 899
(d) 2789

9. (a) 69 840, 69 480, 68 940, 64 980
(b) 28 001, 27 936, 27 396, 26 937
(c) 90 764, 90 746, 9674, 2764

10. (a) 14 369, 14 396, 14 936, 14 963
(b) 58 479, 58 497, 59 798, 59 807
(c) 7237, 7317, 73 217, 77 312

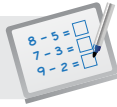
**Specific Learning Focus**

- Compare and order numbers within 100 000.

Suggested Duration

2 periods

Prior Learning

Pupils should be able to compare and order numbers within 10 000 in ascending or descending order. In Grade 4, they are required to do this for numbers within 100 000.

Pre-emptive Pitfalls

This lesson should be relatively less challenging as pupils have been comparing and ordering numbers in the earlier grades. The teacher should emphasise to pupils that they should first compare the numbers and then arrange them in the order specified. Since 5-digit numbers are learnt in this lesson, it might be challenging for some pupils. Provide individual attention to pupils and guide them in writing the numbers in expanded form.

Introduction

Emphasise that when we compare two numbers with the same number of digits, we start comparing the digits in the largest place value first. If the digits are the same, we move on to compare the digits in the next largest place value. In other words, when comparing numbers, we compare the digits from left to right. Number discs, place-value charts and number lines can be used when learning the concept of comparing. Emphasise that on a number line, the numbers increase from left to right.

Problem Solving

In Let's Learn 3 (Textbook 4 P7), the numbers have the digit '0'. Emphasise to pupils that the digit '0' represents a place value of 0. The teacher may ask for individual responses as the questions in Workbook 4A P7 – 10 are being worked out on the board. Encourage pupils to choose their preferred strategy (number line, place-value cards or number discs).

Activities

Get pupils to work in pairs or groups of 4 to solve the questions in 'Practice' (Textbook 4 P7). Distribute number discs and place-value charts (cut and laminate them) to each pair or group.

Resources

- number discs (Activity Handbook 4 P5)
- place-value chart (Activity Handbook 4 P1)
- place-value cards (Activity Handbook 4 P2 – 4)

Mathematical Communication Support

Introduce the terms 'ascending' and 'descending', instead of 'smallest to greatest' and 'greatest to smallest'. Relate the terms to walking up (ascending) and walking down (descending) the staircase.

LEARNING OBJECTIVE

1. Recognise and complete number patterns.

NUMBER PATTERNS

RECAP

What are the missing numbers in the number pattern?

4350	4450	?	?	4750	4850	4950	?
9460	8460	?	6460	5460	4460	?	?

How do you find the missing numbers? Use to find the missing numbers.

IN FOCUS

1. What number is 1000 more than 97 000?
2. What number is 100 less than 53 600?
3. What number is 10 more than 16 330?

How can we use to help us find the answers?

OXFORD UNIVERSITY PRESS NUMBERS TO 100 000 8

LESSON

3

Textbook 4 P8

RECAP

Ask pupils to look at the first number pattern. Ask:

- Are the numbers increasing?

Guide pupils to represent the numbers with number discs. Ask:

- What do you add to make the second number in the pattern?
- Can you do the same for the next number?

Lead pupils to see that the next number is always '100 more than' the number before it.

Working on the second number pattern, guide pupils to see that the next number is always '1000 less than' the number before it.

IN FOCUS

Use number discs to guide pupils in answering the questions presented here.

1. What number is 1000 more than 97 000?

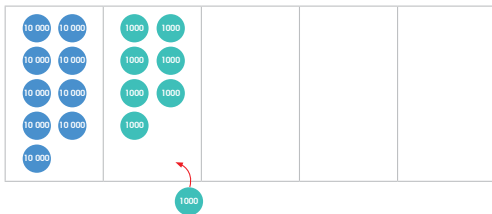

1000 more than 97 000 is 98 000.

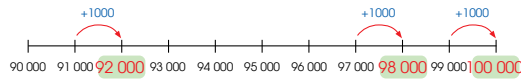

2. What number is 100 less than 53 600?

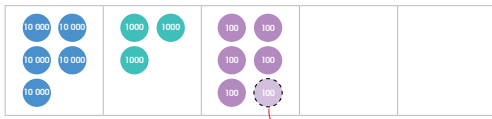

100 less than 53 600 is 53 500.

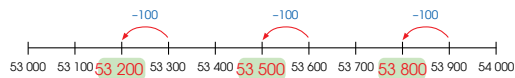

Use number discs to illustrate '1000 more than', '100 less than' and '10 more than' to obtain the answers in Let's Learn 1 to 3.

Then show pupils how to find the missing number using the number lines.

3. What number is 10 more than 16 330?

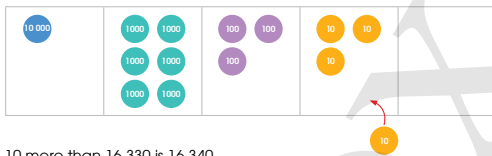

10 more than 16 330 is 16 340.

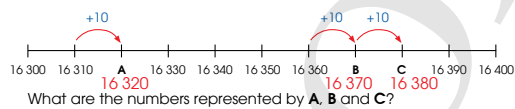

What are the numbers represented by A, B and C?

4. Use  to help you find the answers.



- (a) 10 more than 98 800 is **98 810**.
- (b) 100 more than 43 550 is **43 650**.
- (c) 1000 less than 34 829 is **33 829**.
- (d) **89 099** is 10 more than 89 089.
- (e) **16 610** is 100 more than 16 510.
- (f) **69 211** is 1000 less than 70 211.
- (g) **100** more than 35 980 is 36 080.
- (h) 19 140 is **1000** less than 20 140.
- (i) **10** less than 57 206 is 57 196.
- (j) 68 050 is **100** more than 67 950.

Distribute number discs to pupils and allow them to work in pairs for Let's Learn 4. Then work through each example with the class.

5. Complete the number patterns.
Explain how you get your answers.
- (a) 25 395, 25 405, 25 415, **25 425**, 25 435, **25 445**
- (b) 53 641, 53 541, **53 441**, **53 341**, 53 241
- (c) 30 678, 29 678, **28 678**, 27 678, **26 678**

ACTIVITY  TIME

Work in pairs.

- Think of a 5-digit number.
Show the number with .
- Show the following with the number you have formed.
 - 1 more than,
 - 10 more than,
 - 100 more than, and
 - 1000 more than.
 Write your answers on the .
- Get your partner to check your answers.
- Switch roles and repeat **1** to **3**.
Show the following with the number you have formed.
 - 1 less than,
 - 10 less than,
 - 100 less than, and
 - 1000 less than.

What you need:



For Let's Learn 5, give pupils some time to complete the number pattern and explain verbally how they obtain their answers.

ACTIVITY  TIME

Assign pupils to work in pairs. Provide pupils with number discs. Demonstrate the activity with a pupil for the class to get a better understanding of the activity.

1. Find the missing numbers.
- (a) 10 more than 39 876 is **39 886**.
- (b) 100 less than 47 553 is **47 453**.
- (c) 1000 more than 93 880 is **94 880**.
- (d) **24 518** is 10 less than 24 528.
- (e) **56 330** is 100 more than 56 230.
- (f) **80 022** is 1000 less than 81 022.
- (g) **10** less than 10 298 is 10 288.
- (h) 10 more than 19 990 is **20 000**.
- (i) 100 less than 70 334 is **70 234**.
- (j) **90 563** is 1000 more than 89 563.
- (k) 60 700 is **1000** more than 59 700.
- (l) **10** more than 68 995 is 69 005.
- (m) 96 966 is **100** less than 97 066.

2. Complete the number patterns.
- (a) 17 500, 18 500, 19 500, **20 500**, 21 500
- (b) 49 678, 49 578, **49 478**, 49 378, 49 278
- (c) 32 883, 32 893, **32 903**, **32 913**, 32 923

 Complete Workbook 4A, Worksheet 3 • Pages 11 – 12

PRACTICE 

Work with pupils on the practice questions.

Pupils should be able to do these mentally without the number discs.

Guide pupils to focus on the place-value of the digit based on '___ more than' or '___ less than'.

Independent seatwork

Assign pupils to complete Worksheet 3 (Workbook 4A, P11 – 12).

1. (a) 3809
- (b) 3983
- (c) 7512
- (d) 4779
- (e) 9703
- (f) 8999

2. (a)

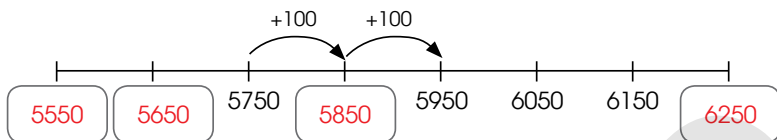

- (b)

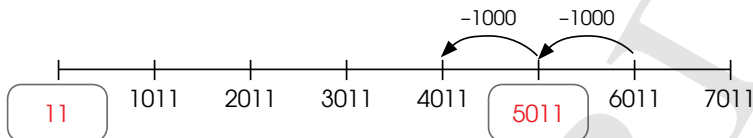

3. (a) 67 544
- (b) 90 099
- (c) 23 055
- (d) 88 115
- (e) 31 909
- (f) 80 798
- (g) 1000
- (h) 1000
- (i) 100

4. (a) 80 650, 80 750
- (b) 97 200, 97 100
- (c) 31 257, 31 237, 31 227
- (d) 70 335, 73 335
- (e) 23 785, 20 785, 18 785

**Specific Learning Focus**

- Recognise and complete number patterns.

Suggested Duration

2 periods

Prior Learning

Pupils should be well-versed with describing and then completing number patterns, as learnt in earlier grades. Explain to pupils that the approach in this lesson is the same, except that the numbers in the number patterns have 5 digits instead of 4 digits. Find the difference between two successive numbers in a number pattern to recognise the pattern. A quick recap of Textbook 4 P8 can be done and elicit individual responses of how they would describe the pattern by asking them the following questions: (i) Is the pattern in an increasing or decreasing order? (ii) What is the difference between two successive numbers? (iii) What operation would you use to find the difference? Emphasise to pupils that the difference is the same between every two successive numbers in the pattern. Encourage the use of number discs to complete the pattern.

Pre-emptive Pitfalls

Pupils might find it challenging to work with patterns involving larger numbers (in this case, 5-digit numbers). However, this can be resolved by emphasising that since they have grasped the concept of writing numbers in expanded form (Lesson 1), and comparing and ordering numbers (Lesson 2), identifying the pattern and difference between two successive numbers should not be an uphill task.

Introduction

Go through 'Let's Learn' (Textbook 4 P11 – 12) with the pupils using number discs and number lines to recognise the pattern and then complete the pattern. For example, in Let's Learn 1 and 2 (Textbook 4 P9), remove or add a number disc and make pupils call out the missing numbers to complete the pattern. Let's Learn 4 (Textbook 4 P10) can be given to pupils as independent seatwork once they have grasped the strategy of recognising and complete number patterns.

Problem Solving

Emphasise to pupils that in Let's Learn 5 (Textbook 4 P11) and question 2 (Textbook 4 P12), they have to first identify the 'jump' between two successive numbers and then add or subtract to complete the number pattern. If the pattern is in an increasing order, the missing number can be found by adding the difference to the preceding number. If the pattern is in a decreasing order, the missing number can be found by subtracting the difference from the preceding number.

Activities

Get pupils to work in groups of 4. Provide them with blank cards and markers. Ask each group to create their own number pattern and ask another group to recognise and complete the pattern. This activity can be carried out for 4 or 5 times.

Resources

- blank cards (Activity Handbook 4 P6)
- place-value chart (Activity Handbook 4 P1)
- markers
- number pattern cards (Activity Handbook 4 P7)

Mathematical Communication Support

Facilitate the critical thinking in pupils by writing a number pattern on the board and ask important questions leading to the completion of the pattern:

- Is the pattern in an increasing or decreasing order?
- What is the difference between two successive numbers?
- What operation would you use to find the difference?
- Is the difference consistent throughout the pattern?
- Can you describe the pattern using terms like 'less than' or 'more than'?
- How can you check if your answer is correct?

ROUNDING NUMBERS

LEARNING OBJECTIVE

1. Round numbers to the nearest 10, 100 or 1000.
2. Estimate the answers in addition and subtraction.

LESSON
4

ROUNDING NUMBERS

IN
FOCUS

Mrs Ali went shopping. She bought a handbag for \$58, a pair of shoes for \$73 and a dress for \$35. What is the cost of each item rounded to the nearest ten dollars?

LET'S LEARN

Rounding numbers to the nearest ten

- The handbag cost \$58.

58 is between 50 and 60.
58 is nearer to 60 than to 50.
We get 60 when we round 58 to the nearest ten.

58 is **approximately** equal to 60.

$58 \approx 60$

The handbag cost about \$60.

The sign \approx means approximately equal to.

To round a number to the nearest ten, look at the digit in the ones place.

13
CHAPTER 1
OXFORD UNIVERSITY PRESS

IN FOCUS

Ask:

- Mrs Gopal tells her friend that she paid about \$50 for the handbag. Is \$50 a good estimate of the actual price?

Write 'rounding numbers' on the board and ask the class what they think it means.

Then tell the class that a good estimate of the cost of the handbag would be to round it to the nearest ten dollars.

LET'S LEARN

Tell pupils that to round a number to the nearest ten, we need to look for the tens nearest to the number.

For Let's Learn 1, ask:

- What are the tens before and after the number 58? Draw a number line on the board with markings from 50 to 60. Ask a pupil to mark the number 58 on the number line. Highlight that 58 is between 5 tens (50) and 6 tens (60).

Then ask:

- Which tens is nearer to the number 58?

So, 58 is 60 when rounded to the nearest ten. Introduce the 'approximate' sign and explain its use.

2. The pair of shoes cost \$73.

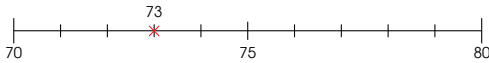

73 is between 70 and 80.
73 is nearer to 70 than to 80.

We get 70 when we round 73 to the nearest ten.

$73 \approx 70$

The shoes cost about \$70.

We round down a number when the digit in the ones place is less than 5.



3. The dress cost \$35.

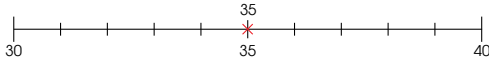

35 is exactly halfway between 30 and 40.

We get 40 when we round 35 to the nearest ten.

$35 \approx 40$

The dress cost about \$40.

We round up a number when the digit in the ones place is 5 or greater.



4. Round 437 to the nearest ten.

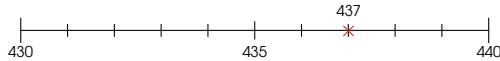

437 is between 430 and 440.

437 is nearer to 440 than to 430.

$437 \approx 440$

Textbook 4 P14

For Let's Learn 2 and 3, repeat the same process and summarise the strategy of looking at the digit in the ones place when rounding to the nearest ten.

For Let's Learn 4, ask:

- What are the tens before and after 437?
- Draw the number line and have a pupil mark 437 on it. Then guide pupils to fill in the blanks

5. Round 7996 to the nearest ten.

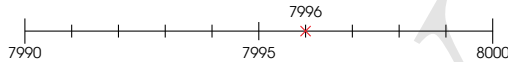

7996 is between 7990 and 8000.

7996 is nearer to 8000 than to 7990.

$7996 \approx 8000$

6. Round each number to the nearest ten.

- | | |
|-----------------------------|-----------------------------|
| (a) 63 \approx 60 | (b) 48 \approx 50 |
| (c) 967 \approx 970 | (d) 591 \approx 590 |
| (e) 3248 \approx 3250 | (f) 6555 \approx 6560 |
| (g) 10 952 \approx 10 950 | (h) 34 599 \approx 34 600 |

7. A number rounded to the nearest ten is 50. What could the original number be?

- (a) What are the possible answers? 45, 46, 47, 48, 49, 50, 51, 52, 53, 54
(b) What is the smallest answer? 45
(c) What is the greatest answer? 54

Use the number line to help you.

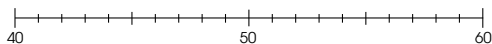

PRACTICE



Round each number to the nearest ten.

- | | | | |
|------------|--------|------------|--------|
| (a) 93 | 90 | (b) 26 | 30 |
| (c) 125 | 130 | (d) 897 | 900 |
| (e) 4305 | 4310 | (f) 9555 | 9560 |
| (g) 72 347 | 72 350 | (h) 19 543 | 19 540 |

Textbook 4 P15

For Let's Learn 5, guide pupils through the same process. Help pupils if they have difficulty seeing the tens after 7990.

For Let's Learn 6, rehearse the strategy for rounding to the nearest ten without the number line before working with the class on the exercises.

For Let's Learn 7, guide pupils to mark the possible answers on the number line using these 3 principles:

- Numbers less than halfway between 2 tens are rounded to the lower ten.
- Numbers more than halfway between 2 tens are rounded to the higher ten.
- Numbers exactly halfway between 2 tens are rounded to the higher ten.

PRACTICE



Work with pupils on the practice questions. Invite pupils to explain how they arrive at their answers.

Independent seatwork

Assign pupils to complete Worksheet 4A (Workbook 4A P13 – 14).

1. (a) 44 is between $\boxed{40}$ and $\boxed{50}$.
 44 is nearer to $\boxed{40}$ than to $\boxed{50}$.
 $44 \approx \boxed{40}$
 - (b) 1006 is between $\boxed{1000}$ and $\boxed{1010}$.
 1006 is nearer to $\boxed{1010}$ than to $\boxed{1000}$.
 $1006 \approx \boxed{1010}$
 - (c) 595 is exactly halfway between $\boxed{590}$ and $\boxed{600}$.
 $595 \approx \boxed{600}$
2. (a) 20
 (b) 140
 (c) 4600
 (d) 32 290
- *3. 55, 56, 57, 58, 59, 61, 62, 63, 64

LET'S LEARN

Rounding numbers to the nearest hundred

1. Junhao, Siti and Bala are taking part in a race. What is the approximate distance that each child has covered?

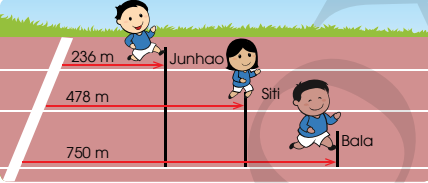

(a) Junhao has covered a distance of 236 m.

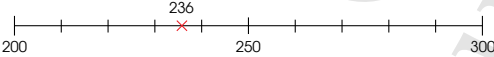

236 is nearer to 200 than to 300.
 We get 200 when we round 236 to the nearest hundred.
 $236 \approx 200$
 Junhao has covered about 200 m.

To round a number to the nearest hundred, look at the digit in the tens place.

(b) Siti has covered a distance of 478 m.

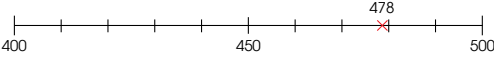

478 is nearer to 500 than to 400.
 We get 500 when we round 478 to the nearest hundred.
 $478 \approx 500$
 Siti has covered about 500 m.

OXFORD UNIVERSITY PRESS NUMBERS TO 100 000 16

Ask the pupils what we should do when we want to find the approximate distance covered by the three runners. Tell pupils in this instance, we can round the numbers to the nearest hundred to get an approximate value.

Rounding a number to the nearest hundred will require us to find the hundreds which are nearest to the number.

For Let's Learn 1(a), ask:

- What are the hundreds before and after 236?

Draw a number line with markings from 200 to 300. Ask a pupil to mark 236 on the line. Highlight that 236 is between 2 hundreds (200) and 3 hundreds (300). Ask:

- Which hundreds is nearer to 236?
- So, 236 is 200 when rounded to the nearest hundred.

Repeat the same process for Let's Learn 1(b) and (c).

Summarise the strategies of rounding to the nearest hundred by looking at the digit in the tens place.

(c) Bala has covered a distance of 750 m.

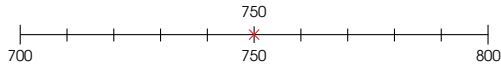

750 is exactly halfway between 700 and 800.
We round it up to 800 to the nearest hundred.
 $750 \approx 800$
Bala has covered about 800 m.

2. Round 4628 to the nearest hundred.

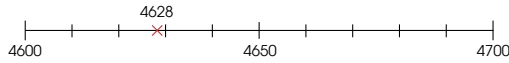

4628 is between 4600 and 4700.
4628 is nearer to 4600 than to 4700.
 $4628 \approx 4600$

3. Round 27 493 to the nearest hundred.

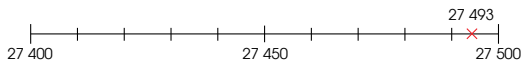

27 493 is between 27 400 and 27 500.
27 493 is nearer to 27 500 than to 27 400.
 $27 493 \approx 27 500$

4. Round each of the following to the nearest hundred.

- (a) $378 \approx 400$ (b) $409 \approx 400$
(c) $7638 \approx 7600$ (d) $5056 \approx 5100$
(e) $63\,248 \approx 63\,200$ (f) $23\,972 \approx 24\,000$

Textbook 4 P17

For Let's Learn 2, ask pupils for the hundreds before and after 4628. Then repeat the process using the number line. Guide pupils to fill in the blanks.

For Let's Learn 3, repeat the process using the number line and then guide pupils to fill in the blanks.

For Let's Learn 4, guide pupils to apply the strategies of rounding to the nearest hundred without using the number line.

Round each number to the nearest hundred.

- (a) 692 **700** (b) 834 **800** (c) 1946 **1900**
(d) 2315 **2300** (e) 9955 **10 000** (f) 10 705 **10 700**

Complete Workbook 4A, Worksheet 4B • Pages 15 – 16

Work in pairs.

1 Look for advertisements on electronics goods in .



2 Pick an item that costs more than \$100.

3 Round the cost of the item to the nearest \$10.

4 Draw a number line to show how you round the cost to the nearest \$10.

Example

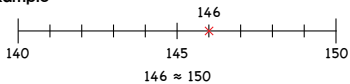

5 Switch roles and repeat 1 to 4.

Try this activity by rounding the costs to the nearest \$100.

Textbook 4 P18

PRACTICE

Work with pupils on the practice questions. Invite pupils to explain how they arrive at their answers.

Independent seatwork

Assign pupils to complete Worksheet 4B (Workbook 4A P15 – 16).

ACTIVITY TIME

Working in pairs, pupils will practise rounding numbers using a real-world context. They will search for items that cost more than \$100 from newspapers. Then using a number line, they will round the price to the nearest \$100.

1. (a) 645 is between $\boxed{600}$ and $\boxed{700}$.
645 is nearer to $\boxed{600}$ than to $\boxed{700}$.
645 \approx $\boxed{600}$
 - (b) 1019 is between $\boxed{1000}$ and $\boxed{1100}$.
1019 is nearer to $\boxed{1000}$ than to $\boxed{1100}$.
1019 \approx $\boxed{1000}$
 - (c) 65 555 is between $\boxed{65\ 500}$ and $\boxed{65\ 600}$.
65 555 \approx $\boxed{65\ 600}$
2. (a) 955 is $\boxed{1000}$ when rounded to the nearest hundred.
 - (b) 1150 is $\boxed{1200}$ when rounded to the nearest hundred.
 - (c) 12 507 is $\boxed{12\ 500}$ when rounded to the nearest hundred.
3. (a) 500
 - (b) 2000
 - (c) 49 600
 - (d) 31 100
 - (e) 36 100

LET'S LEARN

Rounding numbers to the nearest thousand

1.



Nile River
6853 km



Yellow River
5464 km



Okavango River
1500 km

What is the length of each river rounded to the nearest 1000 km?

(a) The Nile River is 6853 km long.

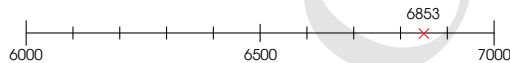

6853 is between 6000 and 7000.
6853 is nearer to 7000 than to 6000.
We get 7000 when we round 6853 to the nearest thousand.

$6853 \approx 7000$

The Nile River is about 7000 m long.

Look at the digit in the hundreds place to round a number to the nearest thousand.



(b) The Yellow River is 5464 km long.

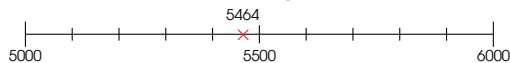

5464 is between 5000 and 6000.
5464 is nearer to 5000 than to 6000.
5464 rounded to the nearest thousand is 5000.

$5464 \approx 5000$

The Yellow River is about 5000 km long.

LET'S LEARN

Start with a short discussion on the length of the longest or most famous rivers in the world. Then read aloud the length of the three rivers in Let's Learn 1. Explain that sometimes large numbers are rounded to the nearest thousand for convenience.

For Let's Learn 1(a), ask:

- What are the thousands before and after 6853?
- Draw a number line on the board. Demonstrate how to count along the number line to mark 6853. Then ask:
- Which thousands are nearer to 6853?
- So, 6853 is 7000 when rounded to the nearest thousand.

Repeat the same process for (b) and (c).

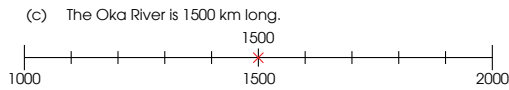

1500 is exactly halfway between 1000 and 2000.
 We round it up to 2000 to the nearest thousand.
 $1500 \approx 2000$
 The Oka River is about 2000 km long.

2. Round 67 584 to the nearest thousand.

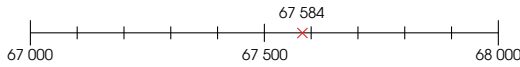

67 584 is between 67 000 and 68 000.
 67 584 is nearer to 68 000 than to 67 000.
 $67 584 \approx 68 000$

3. Round 17 500 to the nearest thousand.

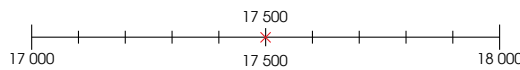

17 500 is exactly halfway between 17 000 and 18 000.
 $17 500 \approx 18 000$

4. Round each number to the nearest thousand.

- (a) $4875 \approx 5000$ (b) $2150 \approx 2000$
 (c) $3901 \approx 4000$ (d) $38 562 \approx 39 000$
 (e) $89 132 \approx 89 000$ (f) $79 860 \approx 80 000$

Textbook 4 P20

Summarise the strategy of rounding to the nearest thousand by looking at the digit in the hundreds place.

For Let's Learn 2 and 3, repeat the process using the number line and guide pupils to fill in the blanks.

For Let's Learn 4, guide pupils to round numbers to the nearest thousand without the number line.

5. A number when rounded to the nearest thousand is 26 000.

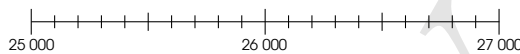

- (a) 25 500 is the smallest possible number.
 (b) 26 499 is the greatest possible number.

PRACTICE

Round each number to the nearest thousand.

- (a) 3499 3000 (b) 5086 5000 (c) 7550 8000
 (d) 9845 10 000 (e) 43 683 44 000 (f) 39 361 39 000
 (g) 89 750 90 000 (h) 65 595 66 000

Complete Workbook 4A, Worksheet 4C • Pages 17 – 19

LET'S LEARN

Estimation

1. 5213 adults and 785 children attended a carnival.
 Find the total number of people at the carnival.
 Estimate to check if your answer is reasonable.

$$5213 + 785 = 5998$$

Method 1



$$\begin{aligned} 5213 &\approx 5000 \\ 785 &\approx 800 \\ 5213 + 785 &\approx 5000 + 800 \\ &= 5800 \end{aligned}$$

5998 is close to 5800, so the answer is reasonable.

Textbook 4 P21

For Let's Learn 5, guide pupils to mark the possible answers on the number line based on these 3 principles:

- Numbers less than halfway between 2 thousands are rounded to the lower thousand.
- Numbers more than halfway between 2 thousands are rounded to the higher thousand.
- Numbers exactly halfway between 2 thousands are rounded to the higher thousand.

PRACTICE

Work with pupils on the practice questions. Invite pupils to explain how they arrive at their answers.

Independent seatwork

Assign pupils to complete Worksheet 4C (Workbook 4A P17 – 19).

1. (a) 5645 is between **5000** and **6000**.
 5645 is nearer to **6000** than to **5000**.
 5645 \approx **6000**
- (b) 9099 is between **9000** and **10 000**.
 9099 is nearer to **9000** than to **10 000**.
 9099 \approx **9000**
- (c) 34 500 is exactly halfway between **34 000**
 and **35 000**.
 34 500 \approx **35 000**
2. (a) 1250 is **1000** when rounded to the nearest thousand.
- (b) 21 500 is **22 000** when rounded to the nearest thousand.
- (c) 59 850 is **60 000** when rounded to the nearest thousand.
3. (a) 1000
 (b) 3000
 (c) 10 000
 (d) 43 000
 (e) 70 000
 (f) 98 000
- *4. 45 499, 44 500

5. A number when rounded to the nearest thousand is 26 000.

(a) **25 500** is the smallest possible number.
 (b) **26 499** is the greatest possible number.

PRACTICE

Round each number to the nearest thousand.

(a) 3499 **3000** (b) 5086 **5000** (c) 7550 **8000**
 (d) 9845 **10 000** (e) 43 683 **44 000** (f) 39 361 **39 000**
 (g) 89 750 **90 000** (h) 65 595 **66 000**

Complete Workbook 4A, Worksheet 4C • Pages 17 – 19

LET'S LEARN

Estimation

1. 5213 adults and 785 children attended a carnival. Find the total number of people at the carnival. Estimate to check if your answer is reasonable.

$5213 + 785 = 5998$

Method 1

5213 \approx 5000
 785 \approx 800
 $5213 + 785 \approx 5000 + 800 = 5800$
 5998 is close to 5800, so the answer is reasonable.

21 CHAPTER 1 OXFORD UNIVERSITY PRESS

LET'S LEARN

Discuss: "Why do we learn rounding numbers?"
 Explain that rounding numbers is useful when doing estimation. Estimation helps us check the reasonableness of our calculation.

Using Let's Learn 1, ask pupils to solve the problem, then guide them to estimate by first rounding 5213 to the nearest thousand (Method 1) and 785 to the nearest hundred. Ask:

- Can we get another estimate that is closer to the answer?

Method 2

$$5213 \approx 5200$$

$$785 \approx 800$$

$$5213 + 785 \approx 5200 + 800$$

$$= 6000$$

5998 is close to 6000, so the answer is reasonable.



There were 5998 people at the carnival.

2. Find the value of $4692 - 708$.
Estimate to check if your answer is reasonable.

$$4692 - 708 = 3984$$

Method 1

$$4692 \approx 5000$$

$$708 \approx 1000$$

$$4692 - 708 \approx 5000 - 1000$$

$$= 4000$$

3984 is close to 4000, so the answer is reasonable.



Method 2

$$4692 \approx 4700$$

$$708 \approx 700$$

$$4692 - 708 \approx 4700 - 700$$

$$= 4000$$

3984 is close to 4000, so the answer is reasonable.



3. Estimate and find the value of each of the following.

(a) $6427 + 568$

(b) $2649 - 1398$

(a) $6427 \approx 6400$

$568 \approx 600$

$6400 + 600 = 7000$

$6427 + 568 = 6995$

(b) $2649 \approx 2600$

$1398 \approx 1400$

$2600 - 1400 = 1200$

$2649 - 1398 = 1251$

Can you estimate in more than one way to check the reasonableness of your answers?



Guide pupils to round both numbers to the nearest hundred (Method 2). Then ask pupils to compare the two methods.

- Which is easier to calculate?
- Which method gives an estimate that is closer to the answer?

Repeat the same process with Let's Learn 2.

For Let's Learn 3, allow pupils to work in pairs. Instruct pupils to estimate using the methods in Let's Learn 1. Go through the example.

OXFORD UNIVERSITY PRESS

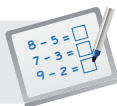
**Specific Learning Focus**

- Round numbers to the nearest 10, 100 or 1000.
- Estimate the answers in addition and subtraction.

Suggested Duration

3 periods

Prior Learning

Rounding numbers is a new concept that is introduced in Grade 4. This is a prerequisite to estimating a value.

Pre-emptive Pitfalls

Pupils might find it challenging to learn a new concept. However, if its application to real life is emphasised (e.g. the estimated amount needed for Mrs Gopal's shopping expenses, the estimated amount of money needed for a school trip, or the estimated number of sandwiches needed to be prepared for a class on a school trip), pupils should find the concept easier to understand.

Introduction

Introduce rounding numbers using number line. In Let's Learn (Textbook 4 P13), point out that 55 is the benchmark to decide if the number should be rounded up or down.

Problem Solving

It is important that pupils identify the range when rounding a number. In Let's Learn 2 (Textbook 4 P17), identify that to round 4628 to the nearest hundred, the range that it lies in is between 4600 and 4700. Using a number line, pupils should identify if 4628 should be placed on the left or right side of 4650.

Activities

Bring cut-outs of newspaper or magazine advertisements, or supermarket price lists to the class. Select the price of an item and round the price to the nearest tens or hundreds.

Resources

- newspapers
- mini whiteboard
- markers

Mathematical Communication Support

Introduce the approximation sign ' \approx ' and explain to pupils that this sign is used to represent rounding numbers. Write the steps to Let's Learn 2 (Textbook 4 P20) on the board and ask pupils for the range to be indicated on the number line. The middle number is found by adding the two extreme numbers and dividing the sum by two. Encourage pupils to do research and come up with real-life examples of the estimation of 4- and 5-digit numbers (e.g. an estimated population of a district, estimated length of a local river or a bridge, or estimated distance between two towns). Ask pupils to write their findings on chart paper with the approximation sign and put up on the class soft board.

LESSON

5

ROMAN NUMERALS

LEARNING OBJECTIVE

1. Understand and write Roman numerals.

ROMAN NUMERALS

IN
FOCUS



What do the letters on the clock represent?

LET'S LEARN

1. The letters on the clock are Roman numerals. Write the Roman numerals for 1 to 8.

I = 1	IV = 4
II = 2	V = 5
III = 3	VI = 6
	VII = 7
	VIII = 8

V is 5. So I before V is 1 less than 5.



2. Write the Roman numerals for 9 and 10.

IX = 9
X = 10

X is 10. So I before X is 1 less than 10.



LESSON
5

IN
FOCUS

Ask pupils to look at the letters on the clock. Let them know that the letters on the clock are known as Roman numerals. Get them to recall the numbers shown on a typical analogue clock and compare to the clock in In Focus.

LET'S LEARN

In Let's Learn 1, introduce the Roman numerals for 1 to 8. Guide them to see that since I is 1 and V is 5, I before V is 1 less than 5, while I after V is 1 more than 5.

In Let's Learn 2, lead pupils to see that for 9 and 10, X is used when writing the Roman numerals. Explain that since I is 1 and X is 10, I before X is 1 less than 10.

23 CHAPTER 1
OXFORD UNIVERSITY PRESS

Textbook 4 P23

3. Write the Roman numerals for 11 to 19.

- XI = 11
- XII = 12
- XIII = 13
- XIV = 14
- XV = 15
- XVI = 16
- XVII = 17
- XVIII = 18
- XIX = 19



4. The Roman numerals for numbers to 100 make use of other letters.

- XX = 20
- XXX = 30

- XL = 40
- L = 50
- LX = 60
- LXX = 70
- LXXX = 80

- XC = 90
- C = 100

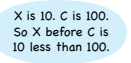
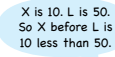

5. What number does XXXIX represent?

XXX = 30 and IX = 9
XXXIX represents 39.



PRACTICE

1. The Gregorian calendar is named after Pope Gregory XIII. What number does XIII represent? 13

2. What numbers do these represent?

- (a) XIV = 14
- (b) XXV = 25
- (c) LX = 60
- (d) XCI = 91

OXFORD UNIVERSITY PRESS

NUMBERS TO 100 000

24

Textbook 4 P24

In Let's Learn 3, introduce to pupils the Roman numerals for 11 to 19. Lead them to see that XII can be broken into X and II, where X is 10 and II is 2, so XII is 10 + 2 = 12. Ask pupils why XIX is 19.

In Let's Learn 4, lead pupils to see that Roman numerals for numbers to 100 make use of other letters (L and C). Explain to them that L is 50 and C is 100.

In Let's Learn 5, help pupils to see XXXIX as a combination of XXX and IX, and hence find what number XXXIX represents.

PRACTICE



Work with pupils on the practice questions.

For better understanding, select items from **Worksheet 5** and work these out with the pupils.

3. Write the Roman numerals for these numbers.

- (a) XIX = 19
- (b) XLIII = 43
- (c) LXXV = 75
- (d) XCIX = 99

Complete Workbook 4A, Worksheet 5 • Pages 20 – 21



MIND WORKOUT

A number has five digits.
The digit 4 is in the thousands place.
Two digits in the number are 3.
The digit 3 stands for 30 000 and 3.
The value of the digit 8 is 800.
The value of 5 is 50.
The number is 34 853.

MATHS JOURNAL

Mr Tan earns \$2650 a month.
The following shows his living expenses for one month.

Room rental: \$650	Transport: \$308
Clothes: \$114	Entertainment: \$145
Food: \$489	

Does Mr Tan have enough money to pay for his living expenses?
Describe how you can use estimation to find out.

25

CHAPTER 1

OXFORD UNIVERSITY PRESS

Textbook 4 P25

Independent seatwork

Assign pupils to complete Worksheet 5 (Workbook 4A P20 – 21).

1.

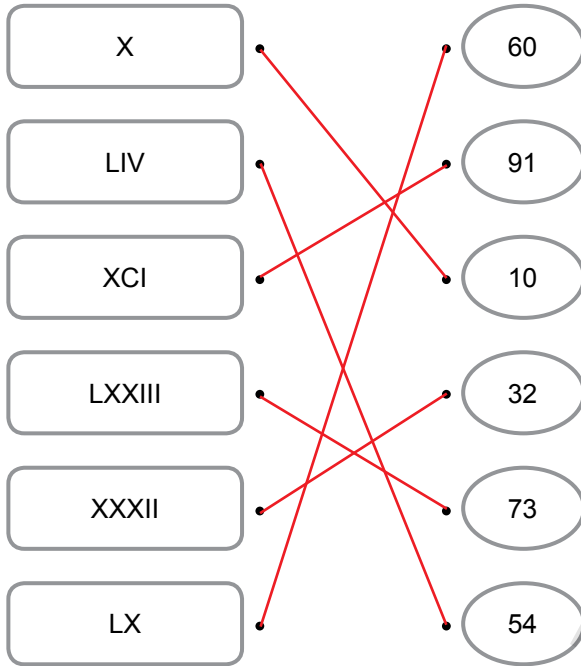

2.

Number	Roman Numeral
12	XII
20	XX
37	XXXVII
49	XLIX
53	LIII
65	LXV
74	LXXIV
88	LXXXVIII
100	C

OXFORD UNIVERSITY PRESS

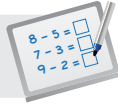

Specific Learning Focus

- Understand and write Roman numerals.

Suggested Duration

2 periods

Prior Learning

Roman numerals have not been introduced to pupils in the earlier grades. However, they should be familiar with them since they come across Roman numerals on items like watches, clocks, home address plaques and historical buildings.

Pre-emptive Pitfalls

This should be a relatively easy lesson, where pupils are introduced to Roman numerals, which are a numeral system that originated in ancient Rome. Roman numerals are denoted by letters of the alphabet.

Introduction

The teacher may share the history behind Roman numerals during the lesson and invite pupils who know about the history to share with their classmates. Introduce the symbols on the board in the form of a table:

1 to 3	as	I, II, III
5	as	V
4	as	IV
6, 7, 8	as	VI, VII, VIII
10	as	X
9	as	IX
11 to 18	as	XI, XII, XIII, ..., XVIII
19, 20, 30	as	XIX, XX, XXX
50	as	L
40	as	XL
60	as	LX
70	as	LXX
80	as	LXXX
100	as	C (century)
90	as	XC

Problem Solving

Explain to pupils that 10 is represented by X in Roman numerals and C represents 100. Emphasise that XC is 10 less than 100, which is 90. Also, since L is 50, 'X' before or after 'L' is 10 less or 10 more than 50, so LX is 60 and LXXX is $50 + 10 + 10 + 10 = 80$.

Activities

Ask pupils to bring cut-outs of pictures with Roman numerals (e.g. a historic building with Roman numerals on it or a grandfather clock). Provide them with chart paper and glue, and have them present to the class real-life examples of Roman numerals. Put up the chart papers on the class soft board.

Resources

- chart paper
- scissors
- glue
- Roman numeral cards (Activity Handbook 4 P8)

Mathematical Communication Support

Discuss the hieroglyphs (Egyptian) and the Roman history, but not in detail. Talk about the Roman and Egyptian civilisations and then explain that Roman numerals are no longer in use now, but we still see them in real life, such as on buildings, addresses and clocks.

PROBLEM SOLVING, MATHS JOURNAL AND PUPIL REVIEW



Mind Workout

Date: _____

Think of the greatest and the smallest numbers which can be rounded to the nearest hundred to get 85 500.

The numbers are and .

22 Chapter 1

OXFORD
UNIVERSITY PRESS



Mind Workout

Hints:

Draw a number line to include the hundreds before and after 85 500.

Mark the midpoint between the hundreds and use the principles of rounding to find the answers.

Workbook 4A P22

3. Write the Roman numerals for these numbers.

- (a) XIX = 19 (b) XLIII = 43
 (c) LXXV = 75 (d) XCIX = 99

Complete Workbook 4A, Worksheet 5 • Pages 20–21



MIND WORKOUT

A number has five digits.
 The digit 4 is in the thousands place.
 Two digits in the number are 3.
 The digit 3 stands for 30 000 and 3.
 The value of the digit 8 is 800.
 The value of 5 is 50.
 The number is **34 853**.

MATHS JOURNAL

Mr Tan earns \$2650 a month.
 The following shows his living expenses for one month.

Room rental: \$650	Transport: \$308
Clothes: \$114	Entertainment: \$145
Food: \$489	

Does Mr Tan have enough money to pay for his living expenses?
 Describe how you can use estimation to find out.

Textbook 4 P25



MIND WORKOUT

If pupils have difficulties solving the problem, facilitate by asking the following questions:

- Is the place value of each digit given?
- What can you use to arrange the 5-digit number?

Ten Th	Th	H	T	O
3	4	8	5	3

Ans: 34 853



MATHS JOURNAL

Pupils are to work individually and then compare their estimation with their partner.

I know how to...

- count to 100 000.
- write numbers up to 100 000 in numerals and in words.
- tell the value of a digit in a number.
- compare and order numbers within 100 000.
- complete number patterns.
- round whole numbers to the nearest ten.
- round whole numbers to the nearest hundred.
- round whole numbers to the nearest thousand.
- read and write Roman numerals I to C.

SELF-CHECK



The self-check can be done after pupils have completed **Review 1** (Workbook 4A P23 – 26).

SELF-CHECK



Textbook 4 P26

1. (a) 35 060
(b) 80 308
2. (a) Fourteen thousand, three hundred and fifty-six
(b) Sixty thousand and twenty
3. (a) 7000
(b) hundreds
(c) 5
(d) 900
4. (a) 2000
(b) 67 908
(c) 500
(d) 90 000
5. 21 347, 23 073, 23 800, 24 009
6. 40 870, 40 807, 4780, 4078
7. LIX
8. (a) 89 090, 89 190
(b) 40 950, 36 950
9. (a) 3020
(b) 2100
(c) 12 000

10.

Days of the week	Number of Children	Rounded to the nearest ten
Monday	853	850
Tuesday	1007	1010
Wednesday	452	450
Thursday	998	1000
Friday	315	320
Saturday	1983	1980
Sunday	2017	2020

11.

Across (round to the nearest hundred):	Down (round to the nearest thousand):
a. 7364	c. 3547
b. 5973	e. 47 495
c. 40 813	f. 27 764
d. 854	g. 7499

MULTIPLICATION AND DIVISION

CHAPTER

2

Multiplication and Division CHAPTER 2

Which boxes can hold exactly 8 doughnuts?

Box A
Box B
Box C

FACTORS LESSON 1

IN FOCUS

Box A
Box B
Box C

Can you write a multiplication equation to show the number of doughnuts in each box?

27 CHAPTER 2 OXFORD UNIVERSITY PRESS

Textbook 4 P27

Related Resources

NSPM Textbook 4 (P27 – 60)
NSPM Workbook 4A (P27 – 58)

Materials

Number discs, numeral cards, magnetic buttons, coloured counters, toothpicks, play money, division algorithm template, mini whiteboard, markers, hundred chart and dice (0 to 9)

Lesson

Lesson 1 Factors
Lesson 2 Multiples
Lesson 3 Multiplying by a 1-digit number
Lesson 4 Multiplying by a 2-digit number
Lesson 5 Dividing by a 1-digit number
Lesson 6 Solving Word Problems
Problem Solving, Maths Journal and Pupil Review

INTRODUCTION

In Grade Four, pupils would have the prerequisite mastery in multiplication tables to learn the concept of factors and multiples. Pupils will learn to express a whole number as a product of two factors. To find the multiple of a number, they will learn to multiply it by another whole number. They will learn that factors and multiples are related to multiplication. Activities incorporating games provide learning experiences for pupils to differentiate the two concepts. Understanding common factors and common multiples will be useful in later chapters (simplifying fraction and changing unlike fractions to like fractions).

This chapter will expand the multiplication and division algorithms to include 4-digit numbers. Pupils are encouraged to estimate the reasonableness of their calculated answers by rounding (Chapter 1). For problem solving, pupils will work in groups to create and solve 3-step word problems as well as non-routine problems involving heuristics.

LESSON

1

FACTORS

LEARNING OBJECTIVES

1. List all factors of a whole number within 100.
2. Determine if a 1-digit number is a factor of a given number.
3. Identify the common factors of two whole numbers.

Multiplication and Division

CHAPTER

2

IN



FOCUS

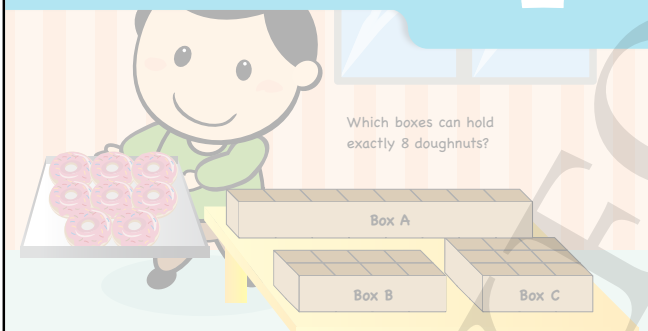

FACTORS

IN  FOCUS



Box A



Box B



Box C

Can you write a multiplication equation to show the number of doughnuts in each box?

27 CHAPTER 2

LESSON
1

OXFORD
UNIVERSITY PRESS

Using the chapter opener, explore the question:

- Which box can hold exactly 8 doughnuts?

Draw 3 rectangular arrays to represent the boxes on the board and use 8 magnetic buttons to represent the doughnuts.

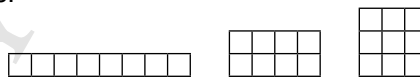

Ask pupils to volunteer to arrange the 8 buttons inside the boxes. Ask pupils if there are equal rows of doughnuts in each box. Allow them to work in pairs to try writing a multiplication equation for the number of doughnuts for each box.

Textbook 4 P27

1. **Box A** 

$8 = 1 \times 8$

The product of 1 and 8 is 8.

8 can be divided exactly by 1.
8 can be divided exactly by 8.

Box B 

$8 = 2 \times 4$

The product of 2 and 4 is 8.
1, 2, 4 and 8 are **factors** of 8.

Can 8 be divided exactly by 2 or 4?

Are there equal rows of 3 doughnuts in Box C?

Box C 

8 cannot be divided exactly by 3.

3 is not a factor of 8.

2. What are all the factors of 16?



$16 = 1 \times 16$



$16 = 2 \times 8$



$16 = 4 \times 4$

The factors of 16 are 1, 2, 4, 8 and 16.

Textbook 4 P28

Let's Learn 1

Box A: Lead pupils to see the rectangular arrangement of 1 row of 8 doughnuts. So, it is $8 = 1 \times 8$.

Refresh pupils on the term '**product**' and relate it to the division concept of ' $8 \div 1 = 8$ ' and ' $8 \div 8 = 1$ '.

Box B: Ask:

- How many equal rows of 4 are there?

Write the multiplication equation ' $8 = 2 \times 4$ ' on the board, then using division determine if 2 and 4 are factors of 8. Referring to the example on Box A and B, stress that '8 can be divided exactly by 1, 2, 4 and 8. So 1, 2, 4 and 8 are factors of 8.

Box C: With the unequal number of doughnuts in each row, show that it is not possible to write a product of two numbers to give 8 for this arrangement. Test that 8 is not divisible by 3. Hence, 3 is not a factor of 8.

For Let's Learn 2, allow pupils to work in groups. Distribute 16 counters to each group to represent the buttons. Guide them to form different rectangular arrays. Ask for the multiplication equation for each array and write them on the board. Finally, list all the factors of 16.

3. Is 7 a factor of 16?

$$\begin{array}{r} 2 \\ 7 \overline{) 16} \\ \underline{14} \\ 2 \end{array}$$

There is a remainder when we divide 16 by 7.
16 cannot be divided exactly by 7.

7 is not a factor of 16.

4. Find all the factors of 28.

$28 = 1 \times 28$

$28 = 2 \times 14$

$28 = 4 \times 7$

Look for factors by dividing.

The factors of 28 are 1, 2, 4, 7, 14 and 28.

5. What are all the factors of 100?

$100 = 1 \times 100$

$100 = 2 \times 50$

$100 = 4 \times 25$

$100 = 5 \times 20$

$100 = 10 \times 10$

The factors of 100 are 1, 2, 4, 5, 10, 20, 25, 50, 100

6. What are all the **common factors** of 24 and 32?

$24 = 1 \times 24$

$24 = 2 \times 12$

$24 = 3 \times 8$

$24 = 4 \times 6$

$32 = 1 \times 32$

$32 = 2 \times 16$

$32 = 4 \times 8$

Factors of 24: 1, 2, 3, 4, 6, 8, 12, 24

Factors of 32: 1, 2, 4, 8, 16, 32

The common factors of 24 and 32 are 1, 2, 4 and 8.

Textbook 4 P29

For Let's Learn 3, tell pupils we can use division to test if a whole number is a factor. Focusing on the 'remainder', stress that if the remainder is '0', the number is a factor otherwise it is not.

For Let's Learn 4 and 5, guide pupils to see how the factors can be obtained systematically by dividing by 1, then by 2 and so on... until the factors start to repeat.

For Let's Learn 6, write 24 and 32 on the board. Get pupils to suggest the common factors of the two numbers. Hint:

- Think of numbers by which both 24 and 36 can be divided exactly without remainder?

Allow pupils to work in pairs to list down all the factors of 24 and 32. Write the factors of both numbers on the board and ask pupils to circle the common numbers in both lists.

7. What are all the common factors of 8 and 36?

Factors of 8: 1, 2, 4, 8

Factors of 36: 1, 2, 3, 4, 6, 9, 12, 18, 36

The common factors of 8 and 36 are 1, 2, 4.

ACTIVITY TIME

Work in pairs.

1. Throw Four times to form a pair of 2-digit numbers.

What you need:

2. Write the factors of each number on the .

Example

$12 = 1 \times 12$	$36 = 1 \times 36$
$12 = 2 \times 6$	$36 = 2 \times 18$
$12 = 3 \times 4$	$36 = 3 \times 12$
	$36 = 4 \times 9$

What do you notice about the factor 1 of any pair of numbers?



3. Compare the two sets of factors.

Look for factors that are common to both sets.

4. Write down all the common factors of the two 2-digit numbers.

PRACTICE

1. List all the factors of each number.

(a) 15 1, 3, 5, 15

(b) 48 1, 2, 3, 4, 6, 8, 12, 16, 24, 48

(c) 63 1, 3, 7, 9, 21, 63

(d) 80 1, 2, 4, 5, 8, 10, 16, 20, 40, 80

2. What are all the common factors of each pair of numbers?

(a) 4 and 12 1, 2, 4

(b) 15 and 20 1, 5

Complete Workbook 4A, Worksheet 1 • Pages 27–30

OXFORD UNIVERSITY PRESS

MULTIPLICATION AND DIVISION

30

Textbook 4 P30

Continue working in pairs for Let's Learn 7. Pupils are to list down the factors of both numbers and their common factors. Work through the solution with the class.

ACTIVITY TIME

Pupils will have more practice finding factors and common factors by forming 2-digit numbers using dice. For post-activity discussion, teacher will guide the pupils to see that:

- Some numbers have only two factors, 1 and the number itself.
- A whole number greater than 1 has at least two factors (1 and the number itself).
- The smallest factor of a whole number is always 1 and the greatest is always the number itself.

PRACTICE

Work with pupils on the practice questions.

For better understanding, select items from Worksheet 1 and work these out with the pupils.

Independent seatwork

Assign pupils to complete Worksheet 1 (Workbook 4A P27–30).

Answers Worksheet 1 (Workbook 4A P27–30)

1. (a) $9 = 1 \times 9$
 $9 = 3 \times 3$

The factors of 9 are 1, 3 and 9.

(b) $12 = 1 \times 12$
 $12 = 2 \times 6$
 $12 = 3 \times 4$

The factors of 12 are 1, 2, 3, 4, 6 and 12.

2. (a) $18 = 1 \times 18$
 $18 = 2 \times 9$
 $18 = 3 \times 6$

The factors of 18 are 1, 2, 3, 6, 9, 18.

(b) The factors of 14 are 1, 2, 7, 14.

(c) The factors of 23 are 1 and 23.

(d) The factors of 34 are 1, 2, 17, 34

(e) The factors of 60 are 1, 2, 3, 4, 5, 6, 10, 12, 15, 20, 30, 60

(f) The factors of 84 are 1, 2, 3, 4, 6, 7, 12, 14, 21, 28, 42, 84

3.

12	35	67	40	56	15	5	100
53	25	82	45	10	72	58	30

The numbers end with the digit 5 or 0.

4. The common factors of 36 and 45 are 1, 3, 9.

5. The common factors of 48 and 64 are 1, 2, 4, 8, 16.

6. The common factors of 72 and 98 are 1, 2.

**Specific Learning Focus**

- List all factors of a whole number within 100.
- Determine if a 1-digit number is a factor of a given number.
- Identify the common factors of two whole numbers.

Suggested Duration

4 periods

Prior Learning

Pupils should have grasped the multiplication tables up to 10 in their earlier grades. Factors are formally introduced in this grade as an essential part of multiplication. Pupils should be well-versed with the fact that multiplying two numbers gives us a product and dividing (inverse operation of multiplying) the product by the multiplicand gives the multiplier, and vice versa.

Pre-emptive Pitfalls

The direct relation between factors, multiples and multiplication might be challenging for pupils. Using the C-P-A approach would help pupils to grasp the concepts. This lesson is crucial as at a later stage, the knowledge of factors and multiples will be required when simplifying fractions.

Introduction

The chapter opener (Textbook 4 P27) can be made concrete by bringing in doughnuts and boxes to class, to show pupils the significance of equal and even distribution of the doughnuts in the boxes. Referring to the chapter opener, the multiplication equations representing the number of doughnuts in boxes A and B introduce the concept of factors very well. Emphasise to pupils that factors are numbers that the product can be divided exactly by, without any remainder. Therefore, 1 is a factor of every number.

Problem Solving

Factors can be identified using mental strategy. Reinforce that a number cannot be a factor if dividing the product by that number gives a remainder. When the factors of 2 numbers are listed in ascending order, the common factors can be highlighted, with 1 being the lowest common factor and the last common factor being the highest common factor.

Activities

'Activity time' (Textbook 4 P30) can be carried out in pairs or groups of 4.

Resources

- dice
- markers
- magnetic buttons
- mini whiteboard

Mathematical Communication Support

When working on Let's Learn 7 (Textbook 4 P30) and Question 2 (Textbook 4 P30), write the numbers on the board. For example, to find the factors of 36, ask pupils to mentally read the multiplication tables of 2, 3, 4, 6 and 9. Tell them that 36 cannot be in the multiplication table of 5 or 10 as the digit in the ones place of 36 is not 5 or 0. Encourage pair work once a few sums have been done on the board.

LESSON 2

MULTIPLES

LEARNING OBJECTIVES

1. List the multiples of a given 1-digit number.
2. Determine if a whole number is a multiple of a given 1-digit number.
3. Identify the common multiples of two 1-digit numbers.

MULTIPLES

LESSON 2

IN FOCUS

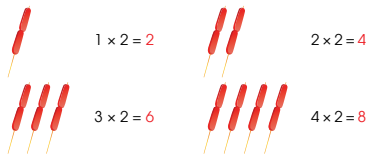

Can you recall the multiplication table of 2 to make more groups of 2?

LET'S LEARN

1. Looking at the number of sausages in the groups, we say 2, 4, 6 and 8 are **multiples** of 2.

$5 \times 2 = 10$	$9 \times 2 = 18$
$6 \times 2 = 12$	$10 \times 2 = 20$
$7 \times 2 = 14$	$11 \times 2 = 22$
$8 \times 2 = 16$	$12 \times 2 = 24$



10, 12, 14, 16, 18, 20, 22 and 24 are also multiples of 2.
We can also see that 2 is a factor of all multiples of 2.

2. List the next 7 multiples of 5.

5, 10, 15, 20, 25, 30, 35, 40, 45, 50, 55, 60

How can you tell if a number is not a multiple of 5?

31 CHAPTER 2

OXFORD
UNIVERSITY PRESS

IN FOCUS

Refer to the sticks of sausages, ask pupils to draw a group of 5 sticks of sausages. Guide the class to write the multiplication equations on the board.

LET'S LEARN

For Let's Learn 1, proceeding from In Focus, continue counting in twos. Then lead pupils to see that 2, 4, 6, 8, 10, 12... are multiples of 2. Guide them to see that 2 is a factor of all multiples of 2.

For Let's Learn 2, lead pupils to recite aloud the multiplication table for 5 and complete the list. Ask pupils what they notice about the digits in the ones place. Then ask if 53 is a multiple of 5.

Textbook 4 P31

3. 18 toothpicks can be arranged into equal groups in different ways.

 $18 = 1 \times 18$

 $18 = 2 \times 9$

 $18 = 3 \times 6$

1, 2, 3, 6, 9 and 18 are factors of 18.

18 is a multiple of 1, 2, 3, 6, 9 and 18.

4. Is 27 a multiple of 3?

$$\begin{array}{r} 9 \\ 3 \overline{) 27} \\ \underline{27} \\ 0 \end{array}$$

3 is a factor of 27.

How can you tell if a number is not a multiple of 3?

27 can be divided exactly by 3.
27 is a multiple of 3.

5. Is 26 a multiple of 3?

$$\begin{array}{r} 08 \\ 3 \overline{) 26} \\ \underline{24} \\ 2 \end{array}$$

Can 26 be divided exactly by 3?

Allow pupils to work in groups for Let's Learn 3. Give each group 18 toothpicks. Ask pupils to divide them into groups with equal numbers of toothpicks. Lead them to see the relationship between factors and multiples.

For Let's Learn 4 and 5, show pupils how division can be used to check if a number is a multiple of a given number by determining whether the division gives a remainder or not.

Lead pupils to see that:

- 27 is a multiple of 3 because 3 is a factor of 27.
- 26 is not a multiple of 3 because 3 is not a factor of 26.

6. Complete the sentences with **factor** or **multiple**.

$$7 \times 9 = 63$$

(a) 7 is a **factor** of 63. (b) 9 is a **factor** of 63.

(c) 63 is a **multiple** of 7. (d) 63 is a **multiple** of 9.

7. Is 60 a **common multiple** of 5 and 6?

Check by division.

$$\begin{array}{r} 12 \\ 5 \overline{) 60} \\ \underline{5} \\ 10 \\ \underline{10} \\ 0 \\ 0 \end{array} \quad \begin{array}{r} 10 \\ 6 \overline{) 60} \\ \underline{6} \\ 0 \\ \underline{0} \\ 0 \\ 0 \end{array}$$

$$60 \div 5 = 12$$

$$60 \div 6 = 10$$

60 can be divided exactly by both 5 and 6.
60 is a common multiple of 5 and 6.

8. What are the first three common multiples of 6 and 9?

List the first 12 multiples of 6 and 9.

Multiples of 6: 6, 12, 18, 24, 30, 36, 42, 48, 54, 60, 66, 72

Multiples of 9: 9, 18, 27, 36, 45, 54, 63, 72, 81, 90, 99, 108

The first three common multiples of 6 and 9 are 18, 36 and 54.

Guide pupils to see that factors and multiples are related in Let's Learn 6.

For Let's Learn 7, get pupils to use division to check if the numbers are multiples of 60. Then ask:

- Can 60 be divided exactly by 5?
- Can 60 be divided exactly by 6?

For Let's Learn 8, guide pupils to use the **systematic listing** method to find the common multiples of two 1-digit numbers.

9. List the first 10 multiples of 4 and 6.

Multiples of 4: 4, 8, 12, 16, 20, 24, 28, 32, 36, 40

Multiples of 6: 6, 12, 18, 24, 30, 36, 42, 48, 54, 60

- (a) What are the first two common multiples of 4 and 6? 12, 24
 (b) Which common multiples are less than 30? 12, 24

10. What is the first common multiple of 6 and 8?

Multiples of 6: 6, 12, 18, 24, 30, 36, 42, 48, 54, 60

Multiples of 8: 8, 16, 24, 32, 40, 48, 56, 64, 72, 80

The first common multiple of 6 and 8 is 24.

ACTIVITY TIME

Work in pairs.

- Take turns to open a 9.
- Place a counter on the multiples of the number shown on your 9.
- Look at the counter placed by you and your partner. Write down the common multiples of the two numbers.
- Repeat 1 to 3 and find the common multiples of another pair of numbers.



Textbook 4 P34

For Let's Learn 9 and 10, repeat the listing process. Then introduce and explain the terms:

- common multiples
- the first common multiple
- the first three common multiples...

Also highlight that the multiple of a number can go on and on, hence they only have to list the number of multiples required to solve the problem.

ACTIVITY TIME

The 100-chart and different coloured counters are used for this activity. Ask:

- What numbers are covered by your counters?
- What numbers are covered by your partner's counters?
- What numbers are covered by two counters?

PRACTICE

1. List the next five multiples for each of the following numbers.

Number	Multiples
6	6, 12, 18, 24, 30, 36, 42
7	7, 14, 21, 28, 35, 42, 49
9	9, 18, 27, 36, 45, 54, 63
25	25, 50, 75, 100, 125, 150, 175
1000	1000, 2000, 3000, 4000, 5000, 6000, 7000

2. Is 28 a multiple of each of the following numbers? Explain your answers.
 (a) 6 No, 28 cannot be divided exactly by 6 (b) 7 Yes, 28 can be divided exactly by 7
3. Is 70 a common multiple of 5 and 6? Explain your answer. No, 70 is not a multiple of 6
4. List the first ten multiples of 3 and 6.
 (a) What are the first two common multiples? 6, 12
 (b) Which common multiples are less than 20? 6, 12, 18
5. What is the first common multiple of 6 and 9? 18
6. Which number does not have a common factor, other than 1, with other numbers in each group?
 (a) 5, 10, 15, 20, 21, 30 21 (b) 6, 12, 24, 25, 30, 36 25
 (c) 7, 14, 21, 28, 35, 40 40

Complete Workbook 4A, Worksheet 2 • Pages 31 – 34

Textbook 4 P35

PRACTICE

Allow pupils to work on their own before working through the solution with the class. Ask pupils for their answers and explanations. For question 6, help pupils understand the requirement of the question.

Independent seatwork

Assign pupils to complete Worksheet 2 (Workbook 4 P31 – 34).

*Workbook:

Question 3: Although 1 and 7 are both acceptable as an answer, encourage pupils to find a number 'other than 1'.

Question 6: Allow pupils to work in pairs before working through with the class.

1. (a) 3, 6, 9, 12, 15, 18, 21, 24, 27, 30, 33, 36
(b) 5, 10, 15, 20, 25, 30, 35, 40, 45, 50, 55, 60
(c) 8, 16, 24, 32, 40, 48, 56, 64, 72, 80, 88, 96
2. (a) factor, multiple
(b) factor, multiple
3. 1 or 7
4. No, 54 cannot be divided exactly by 7 or 8.
5. (a) Multiples of 3: 3, 6, 9, 12, 15, 18, 21, 24, 27, 30, 33, 36
Multiples of 4: 4, 8, 12, 16, 20, 24, 28, 32, 36, 40, 44, 48
The first two common multiples of 3 and 4 are 12 and 24.
- (b) Multiples of 5: 5, 10, 15, 20, 25, 30, 35, 40, 45, 50, 55, 60.
Multiples of 6: 6, 12, 18, 24, 30, 36, 42, 48, 54, 60, 66, 72.
The common multiples of 5 and 6 that are less than 70 are 30, 60.
- (c) Multiples of 3: 3, 6, 9, 12, 15, 18, 21, 24, 27, 30, 33, 36.
Multiples of 5: 5, 10, 15, 20, 25, 30, 35, 40, 45, 50, 55, 60.
The second common multiple of 3 and 5 is 30.
- (d) Multiples of 2: 2, 4, 6, 8, 10, 12, 14, 16, 18, 20, 22, 24.
Multiples of 6: 6, 12, 18, 24, 30, 36, 42, 48, 54, 60, 66, 72.
The third common multiple of 2 and 6 is 18.
- (e) Multiples of 6: 6, 12, 18, 24, 30, 36, 42, 48, 54, 60, 66, 72
Multiples of 9: 9, 18, 27, 36, 45, 54, 63, 72, 81, 90, 99, 108
The second common multiple of 6 and 9 is 36.

*6. 24 and 36

**Specific Learning Focus**

- List the multiples of a given 1-digit number.
- Determine if a whole number is a multiple of a given 1-digit number.
- Identify the common multiples of two 1-digit numbers.

Suggested Duration

4 periods

Prior Learning

Similar to factors, multiples are directly related to multiplication and division. Multiples are formally introduced in this lesson and the multiplication tables are revisited while doing so.

Pre-emptive Pitfalls

The concept of multiples might be challenging as pupils might have difficulties differentiating between factors and multiples.

Introduction

Pupils have been informally introduced to multiples as the numbers in the multiplication tables. Introduce the 'In Focus' activity with concrete materials and revisit the multiplication table of 2. Pupils should be able to list the multiples of numbers in the multiplication tables of 2 to 10 as they have memorised these multiplication tables.

Problem Solving

Guide pupils to use the systematic listing method to find the common multiples of two 1-digit numbers in Let's Learn 8 (Textbook 4 P33).

Activities

In 'Activity Time' (Textbook 4 P34), get pupils to work in pairs. As an extension to the activity, the teacher may get pupils to cross out all the multiples of 2, 3, 5, 7 and 9 on the hundred chart, and identify the numbers that are multiples of 1 and themselves (i.e. these numbers are prime numbers).

Resources

- hundred chart (Activity Handbook 4 P9)
- numeral cards (Activity Handbook 4 P23)
- toothpicks
- magnetic buttons

Mathematical Communication Support

Write the table shown in Textbook 4 P35 on the board and elicit individual responses. Emphasise to pupils that the smallest multiple that is common in both numbers is the lowest common multiple of the two numbers. Differentiate between multiples and factors by asking pupils and emphasising the following:

- What number divides 36 exactly without any remainder?
- 4 is a factor of 36.
- 36 is a multiple of 4.
- Hence a multiple can divide a factor exactly, and a factor can be divided by a multiple exactly.

LESSON

3

MULTIPLYING BY A 1-DIGIT NUMBER

LEARNING OBJECTIVE

1. Multiply numbers up to 4-digit by a 1-digit number.

MULTIPLYING BY A 1-DIGIT NUMBER

LESSON
3

RECAP

A shop sold 7 tables.
Each table was sold for \$121.
How much did the shop collect from the sale of the tables?

$$121 \times 7 = ?$$

Step 1 Multiply the ones by 7.

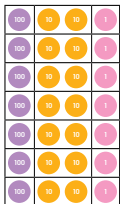

$$\begin{array}{r} 121 \\ \times 7 \\ \hline \end{array}$$

Step 2 Multiply the tens by 7.

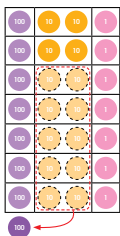

$$\begin{array}{r} 121 \\ \times 7 \\ \hline 47 \end{array}$$

OXFORD
UNIVERSITY PRESS

MULTIPLICATION AND DIVISION

36

Textbook 4 P36

RECAP

Project the problem sum on the board and ask pupils for the number equation. Then write the sum $121 \times 7 = ?$ on the board. Allow pupils to work in pairs to recall the algorithm for multiplying a 3-digit by a 1-digit number learnt in Grade Three. Check for errors:

- multiplication facts
- alignment of numbers according to their place value
- renaming

Next, demonstrate the multiplication algorithm step-by-step using the number discs to relate the concept of place value and the process of renaming.

Step 3 Multiply the hundreds by 7.

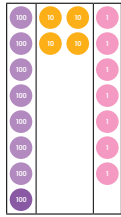

$$\begin{array}{r} 121 \\ \times 7 \\ \hline 847 \end{array}$$

$$121 \times 7 = 847$$

The shop collected \$847 from the sale of the tables.



An electronics store sold 3 such refrigerators.
How much did the store receive from the sale of the refrigerators?

Textbook 4 P37

LET'S LEARN 

1. Each refrigerator was sold for \$1268.

$$1268 \times 3 = ?$$

$$\begin{array}{r} 1268 \\ \times 3 \\ \hline 3804 \end{array}$$

- Step 1 Multiply the ones by 3.
8 ones $\times 3 = 24$ ones
24 ones = 2 tens 4 ones
- Step 2 Multiply the tens by 3.
6 tens $\times 3 = 18$ tens
18 tens + 2 tens = 20 tens
20 tens = 2 hundreds
- Step 3 Multiply the hundreds by 3.
2 hundreds $\times 3 = 6$ hundreds
6 hundreds + 2 hundreds = 8 hundreds
- Step 4 Multiply the thousands by 3.
1 thousand $\times 3 = 3$ thousands

$$1268 \times 3 = 3804$$

The store received \$3804 from the sale of the refrigerators.

Use  to show how you multiply.



Referring to the picture, ask:

- If 1 refrigerator costs \$1268, how much would 3 such refrigerators cost?

Allow pupils to write down the number equation.

For Let's Learn 1, write the number equation on the board.

$$1268 \times 3 = ?$$

Allow pupils to work in groups. Distribute number discs to each group. Ask pupil to represent 1268 using number discs and then to find the answer. Then show pupils how to carry out the multiplication algorithm, relating each step with the use of number discs.

Textbook 4 P38

2. Find the product of 2046 and 7.

$$2046 \times 7 = ?$$

First, we estimate the answer.
 $2046 \approx 2000$
 $2000 \times 7 = 14\ 000$



$$\begin{array}{r} 2\ 0\ 4\ 6 \\ \times \quad 7 \\ \hline 14\ 3\ 2\ 2 \end{array}$$

- Step 1** Multiply the ones by 7.
 $6\ \text{ones} \times 7 = 42\ \text{ones}$
 $42\ \text{ones} = 4\ \text{tens}\ 2\ \text{ones}$
- Step 2** Multiply the tens by 7.
 $4\ \text{tens} \times 7 = 28\ \text{tens}$
 $28\ \text{tens} + 4\ \text{tens} = 32\ \text{tens}$
 $32\ \text{tens} = 3\ \text{hundreds}\ 2\ \text{tens}$
- Step 3** Multiply the hundreds by 7.
 $0\ \text{hundreds} \times 7 = 0\ \text{hundreds}$
 $0\ \text{hundreds} + 3\ \text{hundreds} = 3\ \text{hundreds}$
- Step 4** Multiply the thousands by 7.
 $2\ \text{thousands} \times 7 = 14\ \text{thousands}$

$$2046 \times 7 = 14\ 322$$

Check with your estimated answer.
 Is your answer reasonable?



Textbook 4 P39

3. A metal cube weighs 4538 g.
 How much do 4 identical metal cubes weigh altogether?

$$4538 \times 4 = ?$$

$$\begin{array}{r} 4\ 5\ 3\ 8 \\ \times \quad 4 \\ \hline 3\ 2 \\ 1\ 2\ 0 \\ 2\ 0\ 0\ 0 \\ 1\ 6\ 0\ 0\ 0 \\ \hline 18\ 152 \end{array}$$

Another method of multiplying is shown here.



$$18\ 152$$

$$4538 \times 4 = (8 \times 4) + (30 \times 4) + (500 \times 4) + (4000 \times 4) \\ = 18\ 152$$

4 identical metal cubes weigh **18 152** g altogether.

4. Multiply 6013 by 9.

$$\begin{array}{r} 6\ 0\ 1\ 3 \\ \times \quad 9 \\ \hline 54\ 117 \end{array}$$

5. Multiply.
 Check if your answers are reasonable.

(a) $1230 \times 5 = 6150$ (b) $5121 \times 6 = 30\ 726$

(c) $9361 \times 8 = 74\ 888$ (d) $3685 \times 9 = 33\ 165$

Textbook 4 P40

For Let's Learn 2, first get pupils to estimate the answer by rounding 2046 to the nearest thousand. Then guide pupils to perform the multiplication algorithm. Check pupils' understanding by getting them to fill in the blanks in each step. Finally compare the calculated answer with their estimation to check if the answer is reasonable.

Teacher to demonstrate the multiplication algorithm in Let's Learn 3. Stress the importance of the alignment of numbers according to their place values and the placement of zeros. Get pupils to compare the two methods.

For Let's Learn 4, get pupils to work out the algorithm learnt in Let's Learn 3 before going through.

For Let's Learn 5, allow pupils to use either method to multiply. Encourage them to estimate the answer first and compare their calculated answer against it.

Work in pairs.

- 1 Look at Meiling's working below.

A fan costs \$243.
How much do 5 such fans cost altogether?

$$\begin{array}{r} 243 \\ \times 5 \\ \hline 15 \\ 20 \\ 100 \\ \hline 135 \end{array}$$

5 such fans cost \$135.

ACTIVITY  TIME

What you need:



First check if Meiling's answer is reasonable.



- 2 Is her method correct?
Explain your answer.

- 3 Use  to show the correct method to calculate the answer.

PRACTICE 

Multiply.
Check if your answers are reasonable.

(a) $4576 \times 3 = 13\ 728$

(b) $4098 \times 6 = 24\ 588$

(c) $6340 \times 7 = 44\ 380$

(d) $9 \times 2581 = 23\ 229$

 Complete Workbook 4A, Worksheet 3 • Pages 35 – 38

The activity enables pupils to uncover a common error in multiplication algorithm and explain it using appropriate terms. If time permits, allow the groups to present their findings.

PRACTICE 

Give pupils sufficient time to work out the answers. Highlight errors for class discussion when going through the practice questions.

Independent seatwork

Assign pupils to complete Worksheet 3 (Workbook 4 P35 – 38).

Answers Worksheet 3 (Workbook 4A P35 – 38)

1. (a) 2889
(b) 1168
(c) 3801
(d) 2072

2. (a) $408 \times 8 = 3264$
(b) $673 \times 9 = 6057$

3. (a) 12 195
(b) 45 556
(c) 23 600
(d) 16 824

4. (a) 8445
(b) 5992
(c) 22 710
(d) 20 251

5. (a) $4305 \times 4 = 17\ 220$
(b) $6059 \times 7 = 42\ 413$
(c) $1286 \times 9 = 11\ 574$
(d) $7138 \times 3 = 21\ 414$

MULTIPLYING BY A 2-DIGIT NUMBER

LEARNING OBJECTIVE

1. Multiply numbers up to 3-digit by a 2-digit number.

LESSON
4

MULTIPLYING BY A 2-DIGIT NUMBER



IN FOCUS









A stationery supplier sold 10 such boxes of erasers. How many erasers did she sell altogether?



LET'S LEARN





IN FOCUS

- | | | | |
|---|------|---|-----------------|
|  | × 10 |  | 1 × 10 = 10 |
|  | × 10 |  | 10 × 10 = 100 |
|  | × 10 |  | 100 × 10 = 1000 |

She sold 1000 erasers altogether.
- A restaurant cooks 21 kg of rice each day. What is the total mass of rice they will cook in 30 days?

Method 1

	→ × 10		→ × 3	
$21 \times 10 = 210$				$210 \times 3 = 630$

What do you notice about the product when you multiply by 10?

OXFORD UNIVERSITY PRESS

IN FOCUS

Pose the problem to the pupils. Ask:

- How many erasers were there in each box?
- How many boxes were sold?

Ask pupils to write the number equation on their whiteboard ($100 \times 10 = ?$).

LET'S LEARN

Pupils will learn that they do not need to use the formal algorithm to multiply a whole number by 10 in Let's Learn 1. Lead students to arrive at the strategy of appending a zero to the product when multiplying by 10.

For Let's Learn 2, lead pupils to express 30 as a product of 3 and 10. Explain the three methods of calculating 21×30 with the help of number discs.

Method 2

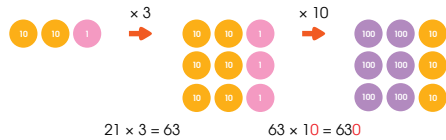

Method 3

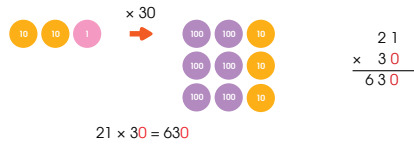

The restaurant will cook 630 kg of rice in 30 days.

3. Bina saves \$135 every month.
How much money will she save in 20 months?

$135 \times 20 = 2700$

Use to show how you multiply.



Bina will save \$ 2700 in 20 months.

4. Multiply.

(a) $52 \times 10 = 520$

(b) $10 \times 943 = 9430$

(c) $30 \times 40 = 1200$

(d) $63 \times 50 = 3150$

(e) $420 \times 70 = 29400$

(f) $20 \times 743 = 14860$

Textbook 4 P43

5. A packet of construction paper contains 15 pieces of paper.
How many pieces of construction paper are there in 36 such packets?

$36 \times 15 = ?$

$$\begin{array}{r} 36 \\ \times 15 \\ \hline 180 \\ 360 \\ \hline 540 \end{array}$$

$36 \times 5 = 180$
 $36 \times 10 = 360$
 $180 + 360 = 540$



$36 \times 15 = 180 + 360 = 540$

There are 540 pieces of construction paper in 36 such packets.

6. Multiply 175 by 12.

$175 \times 12 = ?$

First, we estimate the answer.
 $175 \approx 200$
 $12 \approx 10$
 $200 \times 10 = 2000$



$$\begin{array}{r} 175 \\ \times 12 \\ \hline 350 \\ 1750 \\ \hline 2100 \end{array}$$

$175 \times 2 = 350$
 $175 \times 10 = 1750$
 $350 + 1750 = 2100$



$175 \times 12 = 350 + 1750 = 2100$

2100 is close to 2000, so the answer is reasonable.

7. Multiply.

(a) $57 \times 26 = 1482$

(b) $31 \times 74 = 2294$

(c) $937 \times 49 = 45913$

(d) $67 \times 823 = 55141$

Check if your answers are reasonable.



Textbook 4 P44

Ask pupils to compare the three methods.

Work in pairs for Let's Learn 3. Get pupils to use the three methods taught in Let's Learn 2 to calculate the answer. Pupils may use number discs to illustrate their answers.

For Let's Learn 4, encourage pupils to try working out the answers mentally before using their whiteboard to calculate. Require pupils to show all their workings clearly.



For Let's Learn 5, demonstrate the multiplication algorithm using the addition of 36×5 and 36×10 to find the answer. Emphasise the importance of aligning the numbers according to their place value. For class discussion, ask pupils if they have other ways of multiplying the numbers.

For Let's Learn 6, allow pupils to estimate the product first. Hence, 175×12 can be estimated as 200×10 . Demonstrate the multiplication algorithm using the addition of 175×2 and 175×10 to find the answer. Emphasise the importance of aligning the numbers according to their place values. Ask pupils to check the reasonableness of their answer by comparing it with the estimated value.

For Let's Learn 7, allow pupils to work in pairs. Remind pupils to estimate the answers before calculating.

Play in groups of 4 to 5.

ACTIVITY  TIME

- 1 Take turns to throw the  to get four numbers. What you need: 
- 2 Each player makes two 2-digit numbers. Find the product of these two numbers. The player with the greatest product scores 1 point.
- 3 Repeat 1 and 2. The first player to score 4 points wins!

PRACTICE 

1. Multiply.

- (a) $6 \times 20 = 120$ (b) $8 \times 60 = 480$
 (c) $37 \times 40 = 1480$ (d) $46 \times 50 = 2300$
 (e) $145 \times 30 = 4350$ (f) $80 \times 261 = 20\ 880$

2. Multiply.

Check if your answers are reasonable.

- (a)
$$\begin{array}{r} 68 \\ \times 27 \\ \hline 1836 \end{array}$$
 (b)
$$\begin{array}{r} 73 \\ \times 35 \\ \hline 2555 \end{array}$$
- (c)
$$\begin{array}{r} 248 \\ \times 53 \\ \hline 13\ 144 \end{array}$$
 (d)
$$\begin{array}{r} 569 \\ \times 34 \\ \hline 19\ 346 \end{array}$$

 Complete Workbook 4A, Worksheet 4 • Pages 39 – 42

The game challenges pupils to make two greatest possible 2-digit numbers by throwing the dice. Pupils score points by forming numbers that gives them the greatest product.

PRACTICE 

Give pupils sufficient time to work on the sums. Use pupils' errors for class discussion when working through the practice.

Independent seatwork

Assign pupils to complete Worksheet 4 (Workbook 4 P39 – 42).

1. (a) 240
- (b) 3150
- (c) 2720
- (d) 9060
- (e) 7000
- (f) 1380
- (g) 49 500
- (h) 28 080
- (i) 23 030
- (j) 21 850

2. (a) 792
- (b) 1457
- (c) 3445
- (d) 1008

3. (a)

$$\begin{array}{r}
 217 \\
 \times 15 \\
 \hline
 1085 \\
 2170 \\
 \hline
 3255
 \end{array}$$

(b)

$$\begin{array}{r}
 396 \\
 \times 24 \\
 \hline
 1584 \\
 7920 \\
 \hline
 9504
 \end{array}$$

(c)

$$\begin{array}{r}
 576 \\
 \times 38 \\
 \hline
 4608 \\
 17280 \\
 \hline
 21888
 \end{array}$$

(d)

$$\begin{array}{r}
 938 \\
 \times 47 \\
 \hline
 6566 \\
 37520 \\
 \hline
 44086
 \end{array}$$

4.

$$276 \times 14 = 3864$$

$$68 \times 29 = 1972$$

$$381 \times 11 = 4191$$

$$96 \times 42 = 4032$$

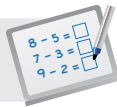

- 1778
- 1972
- 4563
- 4032
- 3864
- 4191

**Specific Learning Focus**

- Multiply numbers up to 4-digit by a 1-digit number.
- Multiply numbers up to 3-digit by a 2-digit number.

Suggested Duration

Lesson 3: 4 periods

Lesson 4: 4 periods

Prior Learning

In lessons 3 and 4, the multiplication algorithm, involving 1-digit multiplicands and then followed by 2-digit multiplicands, is taught. Pupils should be well-versed with multiplication equations.

Pre-emptive Pitfalls

Since division requires the core concepts of multiplication facts, alignment of numbers according to their place value and renaming, some pupils might find lessons 3 and 4 challenging. Give individual attention to pupils and write the steps involved in the multiplication algorithm on the board, using different coloured markers.

Introduction

Recapitulate with pupils that in Grade 3, multiplications involving 1-digit multiplicands were learnt. Revisit the concept by going through such multiplications on the board until the pupils have completely recalled the concept. 'In Focus' (Textbook 4 P37) shows a real-life application of multiplication. Elicit pupils for more real-life examples (e.g. In a class of 23 pupils, each pupil is required to pay Rs 342 for transport for a school trip. How much must 23 pupils pay altogether?). Let's Learn 1 (Textbook 4 P38) needs to be done on the board, with each step verbalised in class. Then, the teacher may prompt pupils for the steps involved in Let's Learn 2 (Textbook 4 P39). In this way, together with ample practice, pupils would grasp the concept of multiplication involving a 1-digit or 2-digit multiplier with a 4-digit multiplicand. Lesson 4 begins with multiplications involving 10, to get pupils to understand that when multiplying a number by 10, a zero is appended to the product. Let's Learn 1 to 4 (Textbook 4 P42 – 43) and questions in Workbook 4A P39 – 40 involve such multiplications. Emphasise the importance of aligning the numbers according to their place value when doing multiplication algorithm.

Problem Solving

Mental strategies can also be used in class, where the 2-digit number can be partitioned into tens and ones, and then multiply the tens and ones individually with the multiplier, and the final product can be obtained by adding the two products obtained. Encourage pupils to estimate the product before finding the exact answer, by rounding the multiplier, to check the reasonableness of their answer.

Activities

'Activity Time' (Textbook 4 P41, 45) can be carried out in pairs or groups of 4.

Resources

- number discs (Activity Handbook 4 P5)
- dice
- play money (Activity Handbook 4 P10)

Mathematical Communication Support

Go through the sums in 'Practice' (Textbook 4 P41, 45) on the board. Discuss the estimated answer to the multiplication first. Encourage individual responses by asking pupils and emphasising the following:

- What numbers would you round the multiplicand and multiplier to?
- What is the estimated product?
- Do not forget to place the zeros, if there are, in the multiplication algorithm.
- Should you start multiplying a 2-digit number from left (tens) to right (ones) or the other way around?
- Is regrouping involved in the multiplication?

Encourage pupils to verbalise the steps when carrying out the multiplication algorithm.

DIVIDING BY A 1-DIGIT NUMBER

LEARNING OBJECTIVE

1. Divide numbers up to 4-digit by a 1-digit number.

DIVIDING BY A 1-DIGIT NUMBER

LESSON
5

RECAP

Mrs Lee bought 8 dictionaries.
She spent \$176 altogether.
How much did each dictionary cost?

$$176 \div 8 = ?$$

We cannot divide 1 hundred into 8 equal groups.
Rename 1 hundred as 10 tens.



Step 1 10 tens + 7 tens = 17 tens
Divide the tens by 8.
17 tens \div 8 = 2 tens with remainder 1 ten

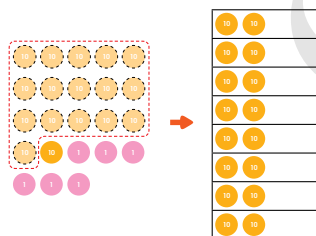

$$\begin{array}{r} 2 \\ 8 \overline{) 176} \\ \underline{16} \\ 1 \end{array}$$

OXFORD
UNIVERSITY PRESS

MULTIPLICATION AND DIVISION

46

Textbook 4 P46

RECAP

Pose the problem to the pupils. Then write the number equation on the board. Allow pupils to work in pairs to recap the division algorithm to divide a 3-digit by a 1-digit learnt in Grade Three.

Teacher to check for errors:

- multiplication/division facts
- alignment of numbers according to place value
- renaming

Work through the division algorithm with whole class using number discs to demonstrate the process of renaming.

If time permits, distribute number discs for pupils to work on the algorithm.

Rename 1 ten 6 ones as 16 ones.

$$\begin{array}{r} 2 \\ 8 \overline{) 176} \\ \underline{16} \\ 16 \\ \underline{16} \\ 0 \end{array}$$

Step 2 Divide the ones by 8.
16 ones \div 8 = 2 ones

$$\begin{array}{r} 22 \\ 8 \overline{) 176} \\ \underline{16} \\ 16 \\ \underline{16} \\ 0 \end{array}$$

$$176 \div 8 = 22$$

Each dictionary cost \$22.



A farmer has 3096 carrots.
He packs them equally into 3 boxes.
How many carrots are there in each box?



47 CHAPTER 2

OXFORD UNIVERSITY PRESS

Textbook 4 P47

LET'S LEARN

LET'S LEARN

1. **Step 1** Divide the thousands by 3.
3 thousands \div 3 = 1 thousand

$$\begin{array}{r} 1 \\ 3 \overline{) 3096} \\ \underline{3} \\ 0 \end{array}$$

Step 2 Divide the hundreds by 3.
0 hundreds \div 3 = 0 hundreds

$$\begin{array}{r} 10 \\ 3 \overline{) 3096} \\ \underline{3} \\ 0 \\ 0 \\ 9 \end{array}$$

Step 3 Divide the tens by 3.
9 tens \div 3 = 3 tens

$$\begin{array}{r} 103 \\ 3 \overline{) 3096} \\ \underline{3} \\ 0 \\ 0 \\ 9 \\ \underline{9} \\ 0 \\ 9 \end{array}$$

Step 4 Divide the ones by 3.
6 ones \div 3 = 2 ones

$$\begin{array}{r} 1032 \\ 3 \overline{) 3096} \\ \underline{3} \\ 0 \\ 0 \\ 9 \\ \underline{9} \\ 0 \\ 9 \\ \underline{9} \\ 6 \\ \underline{6} \\ 0 \end{array}$$

$$3096 \div 3 = 1032$$

There are 1032 carrots in each box.

OXFORD UNIVERSITY PRESS

MULTIPLICATION AND DIVISION

48

Show pupils the division algorithm step-by-step paying particular attention to Step 2.

Get pupils to check the answer by multiplying 1032 by 3.

Textbook 4 P48

2. Divide 3578 by 6.

$$3578 \div 6 = ?$$

First, we estimate the answer.

$$36 \div 6 = 6$$

$$3600 \div 6 = 600$$



Step 1 Divide the hundreds by 6.
 35 hundreds $\div 6 = 5$ hundreds with
 remainder 5 hundreds
 5 hundreds = 50 tens
 50 tens + 7 tens = 57 tens

$$\begin{array}{r} 5 \\ 6 \overline{) 3578} \\ \underline{30} \\ 57 \end{array}$$

Step 2 Divide the tens by 6.
 57 tens $\div 6 = 9$ tens with
 remainder 3 tens
 3 tens = 30 ones
 30 ones + 8 ones = 38 ones

$$\begin{array}{r} 59 \\ 6 \overline{) 3578} \\ \underline{30} \\ 57 \\ \underline{54} \\ 38 \end{array}$$

Step 3 Divide the ones by 6.
 38 ones $\div 6 = 6$ ones with
 remainder 2 ones

$$\begin{array}{r} 596 \\ 6 \overline{) 3578} \\ \underline{30} \\ 57 \\ \underline{54} \\ 38 \\ \underline{36} \\ 2 \end{array}$$

$$3578 \div 6 = 596 \text{ R } 2$$

Textbook 4 P49

Guide pupils to estimate the answer in Let's Learn 2. Help them recall the multiplication table and estimate 3576 as 3600 which is divisible exactly by 6. Next demonstrate the division algorithm step-by-step. Finally check for reasonableness of the answer by comparing it to their estimate.

3. Divide 4361 by 7.

$$4361 \div 7 = ?$$

$$42 \div 7 = 6$$

$$4200 \div 7 = 600$$



Step 1 Divide the hundreds by 7.
 43 hundreds $\div 7 = 6$ hundreds
 with remainder 1 hundred

$$\begin{array}{r} 6 \\ 7 \overline{) 4361} \\ \underline{42} \\ 16 \end{array}$$

Step 2 Divide the tens by 7.
 16 tens $\div 7 = 2$ tens with
 remainder 2 tens

$$\begin{array}{r} 62 \\ 7 \overline{) 4361} \\ \underline{42} \\ 16 \\ \underline{14} \\ 21 \end{array}$$

Step 3 Divide the ones by 7.
 21 ones $\div 7 = 3$ ones

$$\begin{array}{r} 623 \\ 7 \overline{) 4361} \\ \underline{42} \\ 16 \\ \underline{14} \\ 21 \\ \underline{21} \\ 0 \end{array}$$

$$4361 \div 7 = 623$$

Textbook 4 P50

Guide pupils to estimate the answer for Let's Learn 3. Then allow pupils to work in pairs to attempt the division algorithm. Go through the algorithm step-by-step using the blanks to guide the pupils. Compare the answer against the estimate.

4. Divide.

Check if your answers are reasonable.

- (a) $1362 \div 6 = 227$ (b) $4364 \div 8 = 545 \text{ r}4$
 (c) $3459 \div 4 = 864 \text{ r}3$ (d) $4530 \div 3 = 1510$

5. The "Test of Divisibility" helps us decide if a number completely divides another.

Is 2 a factor?

If the last digit is an even number, then 2 is a factor of the number.
 2 is a factor of 200, 138 and 2036.
 2 is not a factor of 187.

Is 3 a factor?

If all the digits add up to a multiple of 3, then 3 is a factor of the number.
 3 is a factor of 624 and 3612.
 3 is not a factor of 1301.

In 624, $6 + 2 + 4 = 12$.
 12 is a multiple of 3.



In 1301, $1 + 3 + 0 + 1 = 5$.
 5 is not a multiple of 3.

Is 4 a factor?

If the last two digits are divisible by 4, then 4 is a factor of the number.
 4 is a factor of 1996 and 4572.

Is 5 a factor?

If the last digit is 0 or 5, then 5 is a factor of the number.
 5 is a factor of 1500 and 4025.

Is 8 a factor?

If the last 3 digits are divisible by 8, then 8 is a factor of the number.

Is 10 a factor?

If the last digit is 0, then 10 is a factor of the number.

Multiples of 1000 are divisible by 8.



Textbook 4 P51

For each sum in Let's Learn 4, ask pupils to estimate the answer first. Give pupils sufficient time to attempt the sums and to check their answer against their estimate. Work through the sum and use pupils' errors for teaching and reinforcing the division algorithm.

In Let's Learn 5, explain to pupils how the "Test of Divisibility" is done to help us decide if a number completely divides another.

Play in groups of 4.

- Take turns to throw .
- Write the number you have thrown in one of the boxes shown.



The numerals can be placed in any box.

- Repeat 1 and 2 until all the boxes are filled.
- Calculate the answer after all the boxes are filled.
- The player with the highest quotient wins!

ACTIVITY TIME

What you need:



ACTIVITY TIME



The game challenges pupils to make decisions in placing the rolled numbers into the appropriate boxes to obtain the highest 4-digit number and the smallest divisor to give the highest quotient.

PRACTICE



PRACTICE



1. Divide.

Check if your answers are reasonable.

- (a) $6 \overline{) 354} \begin{array}{r} 59 \\ \underline{30} \\ 54 \\ \underline{48} \\ 6 \end{array}$ (b) $7 \overline{) 2093} \begin{array}{r} 299 \\ \underline{14} \\ 69 \\ \underline{63} \\ 63 \\ \underline{63} \\ 0 \end{array}$
 (c) $4 \overline{) 6078} \begin{array}{r} 1519 \text{ r}2 \\ \underline{4} \\ 20 \\ \underline{20} \\ 7 \\ \underline{68} \\ 8 \end{array}$ (d) $9 \overline{) 10338} \begin{array}{r} 1033 \text{ r}1 \\ \underline{81} \\ 23 \\ \underline{18} \\ 53 \\ \underline{45} \\ 83 \\ \underline{81} \\ 28 \end{array}$

2. Divide.

Check if your answers are reasonable.

- (a) $168 \div 4 = 42$ (b) $998 \div 9 = 110 \text{ r}8$
 (c) $1086 \div 3 = 362$ (d) $1053 \div 5 = 210 \text{ r}3$
 (e) $6148 \div 6 = 1024 \text{ r}4$ (f) $8960 \div 7 = 1280$

Complete Workbook 4A, Worksheet 5 • Pages 43 - 44

Textbook 4 P52

Give pupils sufficient time to work out the answers. Highlight pupils' errors to them. Then work through the practice questions and use pupils' errors for class discussion.

Independent seatwork

Assign pupils to complete Worksheet 5 (Workbook 4 P43 - 44).

1. (a) $\overline{)51} \text{ r } 5$

$$\begin{array}{r} 7 \overline{) 362} \\ \underline{-35} \\ 12 \\ \underline{-7} \\ 5 \end{array}$$

(b) $\overline{)121}$

$$\begin{array}{r} 7 \overline{) 847} \\ \underline{-7} \\ 14 \\ \underline{-14} \\ 07 \\ \underline{-7} \\ 0 \end{array}$$

(c) $\overline{)103} \text{ r } 3$

$$\begin{array}{r} 9 \overline{) 930} \\ \underline{-9} \\ 030 \\ \underline{-27} \\ 3 \end{array}$$

(d) $\overline{)68}$

$$\begin{array}{r} 8 \overline{) 544} \\ \underline{-48} \\ 64 \\ \underline{-64} \\ 0 \end{array}$$

2. (a) 1080
 (b) 1209 r6
 (c) 1140 r2
 (d) 701

OXFORD
UNIVERSITY PRESS

**Specific Learning Focus**

- Divide numbers up to 4-digit by a 1-digit number.

Suggested Duration

4 periods

Prior Learning

Pupils should be well-versed with the division algorithm, where pupils should be familiar with the positions of the divisor, dividend, quotient and remainder.

Pre-emptive Pitfalls

Reinforce the format of division algorithm using number discs.

Introduction

Recapitulate the division algorithm by revising the key terms 'divisor', 'dividend', 'quotient' and 'remainder'. Emphasise the importance of aligning the numbers according to their place values. Let's Learn 1 (Textbook 4 P48) should be done on the board, while verbalising all the steps.

Problem Solving

Ask pupils to check their answers by carrying out the inverse operation of division, which is multiplication. Get them to multiply the quotient with the divisor to check if it is equal to the dividend. If it is equal, the answer is correct. The "Test of Divisibility" can come in handy when carrying out the division operation and when identifying if a number is a factor. To carry out the various "Test of Divisibility", the following are to be determined:

- T.O.D. of 2: Is the last digit 2, 0 or an even number?
- T.O.D. of 3: Is the sum of all the digits a multiple of 3?
- T.O.D. of 4: Are the last two digits divisible by 4?
- T.O.D. of 5: Is the last digit 0 or 5?
- T.O.D. of 8: Are the last 3 digits divisible by 8?
- T.O.D. of 10: Is the last digit 0?

Activities

'Activity Time' (Textbook 4 P52) can be used as a formative assessment tool. Encourage pupils to assist each other in following the division algorithm format and make sure the numbers are aligned according to their place values.

Resources

- number discs (Activity Handbook 4 P5)
- division algorithm template (Activity Handbook 4 P11)
- dice

Mathematical Communication Support

Verbalise the steps involved in division algorithm by going through them on the board. Guide pupils to use the "Test of Divisibility".

SOLVING WORD PROBLEMS

LEARNING OBJECTIVE

1. Solve up to 3-step word problems.

SOLVING WORD PROBLEMS

LESSON

6

IN FOCUS



Mrs Tan sold 6 identical dresses and 5 identical skirts. She collected \$1109 from the sales. She sold each dress for \$129. How much did she sell each skirt for?

LET'S LEARN

1. **Step 1** Understand the problem. Look for information to help you understand the problem.



53 CHAPTER 2

OXFORD UNIVERSITY PRESS

Textbook 4 P53

IN FOCUS

Ask pupils what they know about the items and the prices and what they need to solve the problem.

LET'S LEARN

Use Let's Learn 1 to model the stages of problem solving.

Step 1: Understand the problem.

- Allow pupils to read the questions silently.
- Underline key elements.
- Set pupils thinking about these questions:
What do I know?
What does the question want us to find?
What do I need to find out first?

Step 2 Think of a plan and carry it out.

Total cost of 6 dresses → ?

\$129 ← Cost of 1 dress

$$\$129 \times 6 = \$774$$

She received \$774 for the 6 dresses.

Total amount received for 6 dresses and 5 skirts → \$1109

Total cost of 5 dresses → \$774

$$\$1109 - \$774 = \$335$$

She received \$335 for the 5 skirts.

\$335 ← Total cost of 5 skirts

Cost of 1 skirt → ?

$$\$335 \div 5 = \$67$$

Mrs Tan sold each skirt for \$67.

Step 3 Check your answer.

Should the cost of each skirt be less than the cost of each dress?

OXFORD UNIVERSITY PRESS MULTIPLICATION AND DIVISION 54

Step 2: Think of a plan and carry it out.

- Ask pupils what is the best way to present the key elements.
- Draw a model for each step and label it clearly including the known and unknown elements. What model do I need to draw first? How can I use it to find other unknown elements?
- Study the model drawn. Do I add, subtract, multiply or divide?
- Then write the number equation to solve for each step and solve them.

Step 3: Check your answer.

- Look back and check if the answer makes sense and is reasonable.

2. Some buttons were sold in large boxes and small boxes. Each large box contained 4500 buttons. A large box contained 6 times as many buttons as a small box. A tailor bought 3 such large boxes and 1 such small box of buttons. How many buttons did she buy in total?

Large box 4500

Small box ?

$$6 \text{ units} = 4500$$

$$1 \text{ unit} = 4500 \div 6 = 750$$

Each small box contained 750 buttons.

4500

$$4500 \times 3 = 13\,500$$

There were 13 500 buttons in 3 large boxes.

13 500 750

$$13\,500 + 750 = 14\,250$$

The tailor bought 14 250 buttons in total.

55 CHAPTER 2 OXFORD UNIVERSITY PRESS

For Let's Learn 2, guide pupils through the 3-step word problem using the stages of problem solving from Let's Learn 1. Set pupils thinking about these questions:

- What do I know?
- How many types of boxes are there?
- What is the relationship between the size of the boxes?
- How many boxes of each did the tailor buy?
- What do we need to find out first?
- What does the question want us to find?

3. A factory made some 3-legged stools and 4-legged chairs. 3000 legs were used to make the stools and chairs. There were 300 more stools than chairs. How many stools and chairs were made?

Make a list to solve the problem.



Number of chairs	Number of legs used for chairs	Number of stools	Number of legs used for stools	Total number of legs used
100	$100 \times 4 = 400$	400	$400 \times 3 = 1200$	1600
200	$200 \times 4 = 800$	500	$500 \times 3 = 1500$	2300
300	$300 \times 4 = 1200$	600	$600 \times 3 = 1800$	3000

300 tables and 600 stools were made.

ACTIVITY TIME

Work in pairs.

- 1 Look at the picture shown.

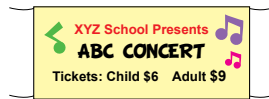

What you need:



- 2 Create a word problem involving any of the operations (+, -, × or ÷).
 3 Show how you solve the problem on .
 4 Exchange word problems with other groups to solve.

Let's Learn 3 is a non-routine question that requires the heuristic strategy of 'Make a List'. Through organised listing, pupils can generate the possible answer that meets all the conditions stipulated in the question. Model the 3-step problem solving:
 Step 1: Lead pupils to see that there should only be 3000 legs and the difference between the number of stools and chairs must be 300.

Step 2: Lead pupils to see that drawing model is not feasible. Guide them to draw the table and explain the steps. Work out the trials with them systematically until the numbers meet the condition stipulated.

Step 3: Check for reasonableness.

ACTIVITY TIME

Pupils are encouraged to pose realistic 3 to 4-digit number word problems. Select some pupils' problems and their solutions for class discussion.

Solve.

1. A laptop costs \$1099 and a tablet costs \$499. What is the total cost of 4 such laptops and 6 such tablets? **\$7390**
2. A bakery sold a total of 3028 coffee buns and blueberry buns. 1560 more coffee buns were sold than blueberry buns. How many coffee buns did the bakery sell? **2294**
3. A shopkeeper had 1246 sacks of rice. Each sack contained 8 kg of rice. He sold 7872 kg of rice. How many sacks of rice did he have left? **262**
4. Mr Wong saved \$350 each month for 26 months. He then spent \$4000. The remaining amount of money was shared equally among his 5 daughters. How much did each daughter receive? **\$1020**
- * 5. Bala had 240 cards and Tom had 780 cards. After Tom gave some cards to Bala, Bala had twice as many cards as Tom. How many cards did Tom give to Bala? **440**

Complete Workbook 4A, Worksheet 6A • Pages 45 - 48

IN FOCUS

$$\begin{array}{l} \text{2 coffee cups} + \text{3 slices of cheesecake} = \text{Rs } 1250 \\ \text{3 coffee cups} + \text{2 slices of cheesecake} = \text{Rs } 1100 \end{array}$$

How much does each slice of cheesecake cost?

PRACTICE

Pupils to work in groups. Remind pupils to follow the 3-step problem solving strategy. Then work through the problems with the class.

Independent seatwork

Assign pupils to complete Worksheet 6A (Workbook 4 P45 - 48).

Note: Teacher can provide assistance to pupils on more challenging word problems marked with *.

1. $7800 \div 4 = 1950$
 $1950 \times 3 = 5850$
 There were 5850 adults.

2. $2040 \times 3 \text{ kg} = 6120 \text{ kg}$
 $9600 \text{ kg} - 6120 \text{ kg} = 3480 \text{ kg}$
 $3480 \text{ kg} \div 5 \text{ kg} = 696$
 696 large bags of flour were packed.

3. $1500 \text{ ml} \div 3 = 500 \text{ ml}$
 $500 \text{ ml} \times 2 = 1000 \text{ ml}$
 $1000 \text{ ml} \times 6 = 6000 \text{ ml}$
 He uses 6000 ml of water to make 6 jugs of fruit punch.

4. $\$25 \times 236 = \5900
 $\$9548 - \$5900 = \$3648$
 $\$3648 \div 8 = \456
 Each table cost \$456.

5. $1344 \div 6 = 224$
 $1280 \div 8 = 160$
 $160 + 224 = 384$
 The baker packed 384 boxes of tarts altogether.

6. $1865 + 767 = 2632$
 $2632 \div 4 = 658$
 $658 - 293 = 365$
 They need to pack 365 more hampers.

- *7. 2 units \rightarrow 64
 1 unit $\rightarrow 64 \div 2 = 32$
 5 units $\rightarrow 32 \times 5 = 160$
 Tom had 160 mables at first.

- *8. 2 units \rightarrow 550 ml
 1 unit $\rightarrow 550 \text{ ml} \div 2 = 275 \text{ ml}$
 6 units $\rightarrow 275 \text{ ml} \times 6 = 1650 \text{ ml}$
 The total volume of water in both bottles was 1650 ml.

PRACTICE 

Solve.

1. A laptop costs \$1099 and a tablet costs \$499.
What is the total cost of 4 such laptops and 6 such tablets? **\$7390**
2. A bakery sold a total of 3028 coffee buns and blueberry buns.
1560 more coffee buns were sold than blueberry buns.
How many coffee buns did the bakery sell? **2294**
3. A shopkeeper had 1246 sacks of rice.
Each sack contained 8 kg of rice.
He sold 7872 kg of rice.
How many sacks of rice did he have left? **262**
4. Mr Wong saved \$350 each month for 26 months.
He then spent \$4000.
The remaining amount of money was shared equally among his 5 daughters.
How much did each daughter receive? **\$1020**
- * 5. Bala had 240 cards and Tom had 780 cards.
After Tom gave some cards to Bala, Bala had twice as many cards as Tom.
How many cards did Tom give to Bala? **440**

Complete Workbook 4A, Worksheet 6A • Pages 45 - 48

IN  FOCUS

$$\begin{array}{l}
 \text{3 cups of coffee} + \text{4 slices of cheesecake} = \text{Rs } 1250 \\
 \text{2 cups of coffee} + \text{4 slices of cheesecake} = \text{Rs } 1100
 \end{array}$$

How much does each slice of cheesecake cost?

Textbook 4 P57

LET'S LEARN 

LET'S LEARN 

Correspondence problems

1. $\text{Rs } 1250 - \text{Rs } 1100 = \text{Rs } 150$
A cup of coffee costs Rs 150.
 $\text{Rs } 150 \times 2 = \text{Rs } 300$
Two cups of coffee cost Rs 300.
 $\text{Rs } 1100 - \text{Rs } 300 = \text{Rs } 800$
Four slices of cheesecake cost Rs 800.
 $\text{Rs } 800 \div 4 = \text{Rs } 200$
Each slice of cheesecake costs Rs 200.

2. Sugar is sold in bags of 200 grams and 500 grams. Bala needs 2400 grams of sugar to bake cupcakes for charity. How many of each bag of sugar should he buy?



Bala can buy 2 bags of 500 grams and 7 bags of 200 grams.

Is there another way to obtain the answer?



3. There are 25 pieces of chocolate in a tin and 40 candy canes in a box. Nora wants to pack the same number of pieces of chocolate and candy canes in a bag. What is the fewest number of tins of chocolate and boxes of candy canes that she should buy?

Multiples of 25: 25, 50, 75, 100, 125, 150, 175, **200**
Multiples of 40: 40, 80, 120, 160, **200**, 240, 280, 320

Nora should buy 8 tins of chocolate and 5 boxes of candy canes.

Ask pupils to interpret the two equations and compare them. Lead them to see that the second equation has one less cup of coffee compared to the first equation, and hence the cost of a cup of coffee can be determined.

For Let's Learn 1, guide pupils to find the cost of a cup of coffee by subtracting the total cost given in the second equation from the total cost given in the first equation. Remind pupils that the cost of each cup of coffee is the same. Likewise, the cost of each slice of cheesecake is the same.

Go through the correspondence problem in Let's Learn 2 with the pupils. Ask pupils if there is another way to obtain the answer.

For Let's Learn 3, emphasise to pupils that the number of items required must be the least. Lead pupils to see that the lowest common multiple of 25 and 40 should be determined to solve this problem.

Textbook 4 P58



- Four belts and three scarves cost \$390. Four belts and four scarves cost \$420. How much does a belt cost? **\$75**
- Sam wants to fill a tank with exactly 4000 millilitres of water. He has two beakers. One has a capacity of 200 millilitres and the other has a capacity of 300 millilitres. How many of each beaker does he need to use? Show two different ways. **8 200-ml beakers and 8 300-ml beakers. 5 200-ml beakers and 10 300-ml beakers.**
- A bell tolls at a regular interval of 20 minutes. A second bell tolls at a regular interval of 50 minutes. They toll together at 3 p.m. At what time will they next toll together? **4.40 p.m.**

Complete Workbook 4A, Worksheet 6B • Pages 49 – 50



MIND WORKOUT

Find the missing numbers.
What pattern do you observe?

$$(1 \times 9) + 2 = 11$$

$$(12 \times 9) + 3 = 111$$

$$(123 \times 9) + 4 = 1111$$

Use the pattern to solve the following.

$$(\underline{1234} \times 9) + \underline{5} = 11\ 111$$

$$(\underline{12345} \times 9) + \underline{6} = 111\ 111$$

How do you solve this?
Share your ideas with the class.



Textbook 4 P59



Check the pupils' understanding by asking if they know what a column and a row are. If possible, get another pupil to verify the answer.

For better understanding, select items from **Worksheet 6** and work these out with the pupils.

Independent seatwork

Assign pupils to complete Worksheet 6B (Workbook 4A P49 – 50).

Answers Worksheet 6B (Workbook 4A P49 – 50)

- $700 - 620 = 80$
Two sacks of potatoes cost Rs 80.
 $80 \div 2 = 40$
A sack of potatoes cost Rs 40.
 - 10×3 litres = 30 litres
 10×1 litre = 10 litres
They need 30 litres of apple juice.
 - Multiples of 6: 6, 12, 18, 24, 30, 36, **42**
Multiples of 7: 7, 14, 21, 28, 35, **42**, 49

After every 42 days, Ahmad and Xinyi have the same day off.
42 days after 10th of March is 22nd of April.
They next have the same day off on 22nd of April.
 - Multiples of 5: 5, 10, 15, 20, 25, **30**
Multiples of 6: 6, 12, 18, 24, **30**, 36

5 bags of apples and 6 bags of bananas cost \$38.
 $6 \times \$38 = \228
30 bags of apples and 36 bags of bananas cost \$228.
- 6 bags of apples and 5 bags of bananas cost \$39.
 $5 \times \$39 = \195
30 bags of apples and 25 bags of bananas cost \$195.

 $\$228 - \$195 = \$33$
11 bags of bananas cost \$33.

 $\$33 \div 11 = \3
1 bag of bananas costs \$3.

 $\$3 \times 6 = \18
6 bags of bananas cost \$18.

 $\$38 - \$18 = \$20$
5 bags of apples cost \$20.

 $\$20 \div 5 = \4
1 bag of apples costs \$4.

 $\$3 + \$4 = \$7$
The total cost of a bag of apples and a bag of bananas is \$7.

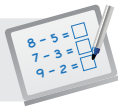
**Specific Learning Focus**

- Solve up to 3-step word problems.

Suggested Duration

4 periods

Prior Learning

Pupils should be well-versed with the 4-step approach to problem solving when solving word problems in their earlier grades.

Pre-emptive Pitfalls

Since pupils are required to comprehend the word problem and go through the 4 steps involved when solving a problem, it might be quite challenging for some pupils. Ample practice (Workbook 4A P45 – 48) and individual attention will help pupils solve word problems with confidence.

Introduction

Use Let's Learn 1 (Textbook 4 P53 – 54) to explain the 4 steps involved when solving a problem. Encourage pupils to do silent reading and highlight the key phrases and information. Ask pupils to do the following:

- identify the information that needs to be found,
- identify which operation(s) should be used,
- translate the information into bar models,
- identify the strategy that should be employed,
- carry out the operation (while carrying out the operation, write mathematical equations and point out that if vertical algorithm is required, ensure that the digits are aligned according to their place values),
- apply the inverse operation (backtrack) or an alternative strategy to check the answer.

Problem Solving

Let's Learn 2 (Textbook 4 P55) requires three different operations. The number of buttons in each small box must be determined first by division. In the next step, to find the total number of buttons in 3 boxes, multiplication is required. Finally, addition is required to find the total number of buttons.

Activities

Divide the class into groups of 4. Provide pupils with mini whiteboards and markers. Ask them to think of a word problem that requires all four operations to solve. Upon writing the word problem on their mini boards, get each pair to swap their mini boards with each other.

Resources

- 4-step approach to problem solving template (Activity Handbook 4 P12)
- markers
- mini whiteboard

Mathematical Communication Support

This lesson involves the heuristic approach and the use of bar models. In Let's Learn 3 (Textbook 4 P56), pupils are required to permute possible answers and tabulate them. Through the correspondence problems (Textbook 4 P58 – 59), algebra and permutations are informally introduced. Encourage pupils to use multiple strategies and come up with different combinations. Question 3 (Textbook 4 P59) involves the listing of multiples of 20 and 50 until the first common multiple is identified. 3 p.m. is the starting time and the lowest common multiple is the duration to be added to 3 p.m. to obtain the answer.

PROBLEM SOLVING, MATHS JOURNAL AND PUPIL REVIEW

PRACTICE

- Four belts and three scarves cost \$390. Four belts and four scarves cost \$420. How much does a belt cost? *\$75*
- Sam wants to fill a tank with exactly 4000 millilitres of water. He has two beakers. One has a capacity of 200 millilitres and the other has a capacity of 300 millilitres. How many of each beaker does he need to use? Show two different ways. *8 200-ml beakers and 8 300-ml beakers, 5 200-ml beakers and 10 300-ml beakers.*
- A bell tolls at a regular interval of 20 minutes. A second bell tolls at a regular interval of 50 minutes. They toll together at 3 p.m. At what time will they next toll together? *4.40 p.m.*

Complete Workbook 4A, Worksheet 6B • Pages 49–50



MIND WORKOUT

Find the missing numbers.
What pattern do you observe?

$$(1 \times 9) + 2 = 11$$

$$(12 \times 9) + 3 = 111$$

$$(123 \times 9) + 4 = 1111$$

Use the pattern to solve the following.

$$(1234 \times 9) + 5 = 11111$$

$$(12345 \times 9) + 6 = 111111$$

How do you solve this?
Share your ideas with the class.



59

CHAPTER 2

OXFORD
UNIVERSITY PRESS



MIND WORKOUT

This Mind Workout is a non-routine problem using the 'Look for the Pattern' strategy. Pupils should be able to recognise the pattern and extend the pattern to the second part.

Textbook 4 P59



Mind Workout

Date: _____

Oranges were sold in 5-kg bags and apples were sold in 4-kg bags. Mrs Lee bought 27 kg of fruits. How many bags of each fruit did she buy?

She bought 3 bags of oranges and 3 bags of apples.

Workbook 4A P51



Mind Workout

A non-routine problem using 'Make a List' strategy which they have encountered earlier in Textbook 4 P58 (Let's Learn 3).

Solution:

Orange 5-kg bags	Mass kg	Mass kg	Apples 4-kg bags	Total Mass 27 kg
1	5	$27 - 5 = 22$	$22 \div 4$ ×	27
2	10	$27 - 10 = 17$	$17 \div 4$ ×	27
3	15	$27 - 15 = 12$	$12 \div 4 = 3$ ✓	27

Answer: 3 bags of oranges and 3 bags of apples



Maths Journal

Look at the working below.

$$\begin{array}{r} 14 \\ 4 \overline{) 5060} \\ \underline{4} \\ 16 \\ \underline{16} \\ 0 \end{array}$$

Is the answer reasonable? Why?

No, it is not complete and it skips the 0s.

Show the correct steps to divide 5060 by 4.

$$\begin{array}{r} 1265 \\ 4 \overline{) 5060} \\ \underline{-4} \\ 10 \\ \underline{-8} \\ 26 \\ \underline{-24} \\ 020 \\ \underline{-20} \\ 0 \end{array}$$

Workbook 4A P52



Maths Journal

This challenges the pupils to uncover errors in the division algorithm. Encourage pupils to use the appropriate terms to explain their answer besides showing the correct steps.

MATHS JOURNAL

Look at the workings shown.
What is wrong with each of them?

$$\begin{array}{r} 253 \\ \times \quad 3 \\ \hline 6159 \end{array} \qquad \begin{array}{r} 23089 \\ \times \quad 5 \\ \hline 17045 \end{array}$$

Explain your answers.

I know how to...

SELF-CHECK

- determine if a 1-digit number is a factor of a given number.
- list all the factors of a given number.
- find the common factors of two given numbers.
- recognise the relationship between factor and multiple.
- list the multiples of a given number.
- determine if a number is a multiple of a given 1-digit number.
- find the common multiples of two given numbers.
- multiply numbers up to 4 digits by a 1-digit number.
- multiply numbers up to 3 digits by a 2-digit number.
- divide numbers up to 4 digits by a 1-digit number.
- solve word problems.

This challenges the pupils to uncover errors in the multiplication algorithm. Encourage pupils to use the appropriate terms to explain their answer besides showing the correct steps.

SELF-CHECK

Before the pupils do the self-check, review the important concepts once more by asking for examples learnt for each objective.

The self-check can be done after pupils have completed **Review 2** (Workbook 4 P53 – 58).

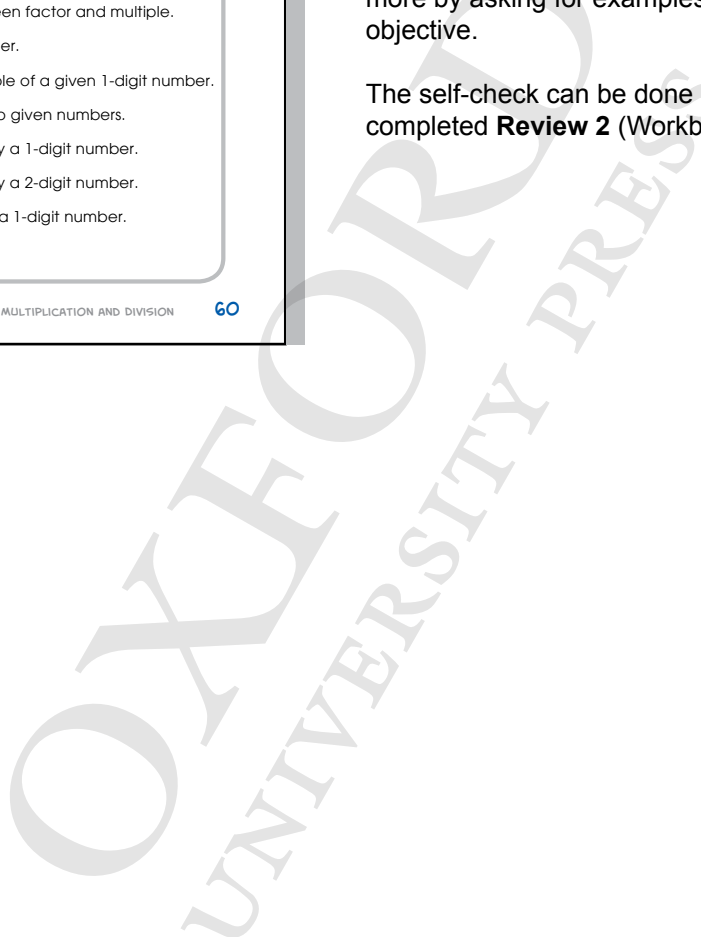

1. (a) 1, 2, 3, 4, 6, 8, 9, 12, 18, 24, 36, 72
 (b) 1, 2, 3, 4, 6, 8, 12, 16, 24, 32, 48, 96

2. 1, 3, 9, 27

3. No, 61 is not a multiple of 7.

4. (a) Multiples of 4: 4, 8, 12, 16, 20, 24, 28, 32, 36, 40, 44, 48
 Multiples of 5: 5, 10, 15, 20, 25, 30, 35, 40, 45, 50, 55, 60

The first common multiple of 4 and 5 is **20**.

- (b) Multiples of 6: 6, 12, 18, 24, 30, 36, 42, 48, 54, 60, 66, 72

Multiples of 8: 8, 16, 24, 32, 40, 48, 56, 64, 72, 80, 88, 96

The second common multiple of 6 and 8 is **48**.

5. (a) 24 102
 (b) 17 468
 (c) 13 050
 (d) 3915
 (e) 323
 (f) 325 r1

6. $5 \times 136 = 680$
 $8 \times 257 = 2056$
 $680 + 2056 = 2736$

She sold 2736 stalks of roses altogether.

7. $128 \times 12 = 1536$
 $1680 - 1536 = 144$
 $144 \div 6 = 24$

24 boxes were needed for the remaining eggs.

8. $55 \times 125 = 6875$
 $45 \times 80 = 3600$
 $3600 + 6875 = 10\,475$

Meiling used 10 475 beads in total.

9. $219 + 673 = 892$
 $892 \times 2 = 1784$

1784 people registered for the competition in the end.

10. $2793 - 325 = 2468$
 $2468 \div 4 = 617$
 $617 + 325 = 942$

There were 942 apples at first.

11. $\$2590 - \$320 = \$2270$
 $\$2270 \div 5 = \454

$\$454 + \$2590 = \$3044$
 Raju had \$3044 at first.

FRACTIONS

CHAPTER

3

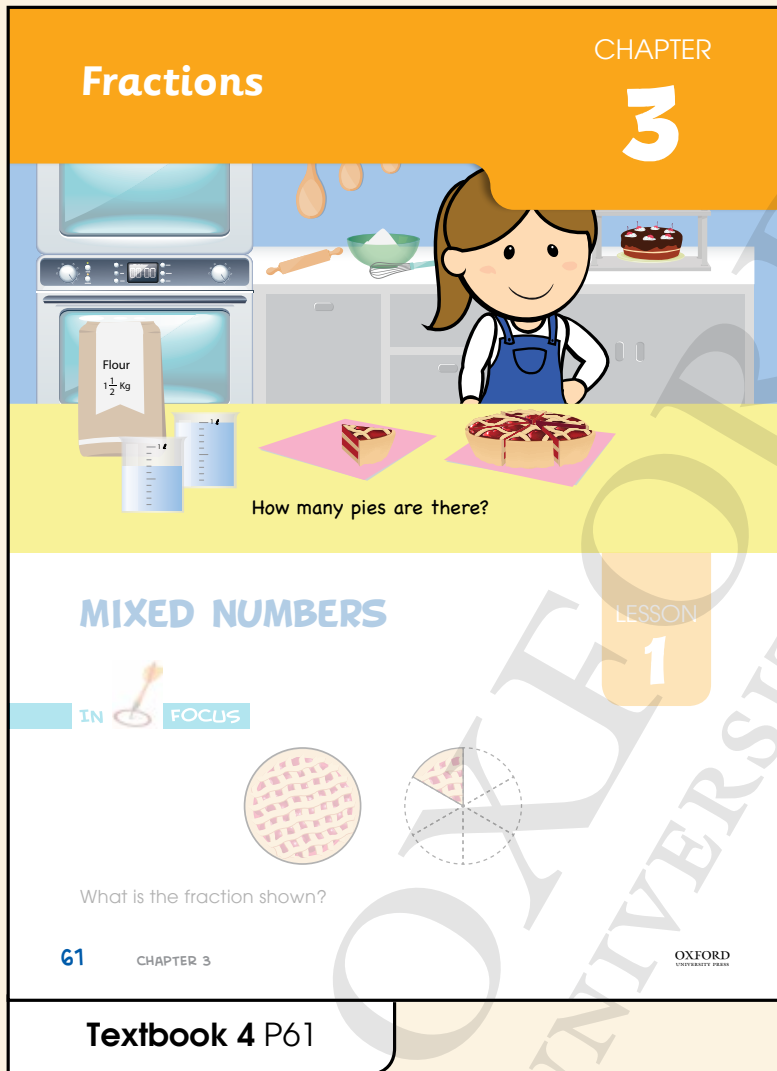

Related Resources

NSPM Textbook 4 (P61 – 101)
NSPM Workbook 4A (P59 – 92)

Materials

Fraction cards, fraction discs, multilink cubes, numeral cards, drawing block, markers, fraction bars

Lesson

Lesson 1 Mixed Numbers
Lesson 2 Improper Fractions
Lesson 3 Converting Fractions
Lesson 4 Comparing and Ordering Fractions
Lesson 5 Fraction of a Set
Lesson 6 Adding Fractions
Lesson 7 Subtracting Fractions
Lesson 8 Solving Word Problems
Problem Solving, Maths Journal and Pupil Review

INTRODUCTION

This chapter will get pupils to explore further what they have already learnt in Grade Three: Comparing and Ordering Fractions, Adding and Subtracting like and related fractions.

Adopting the spiral approach, pupils will explore mixed numbers, improper fractions and their relationship. Pupils will also solve word problems using part-whole and comparison models.

LEARNING OBJECTIVES

1. Write mixed numbers.
2. Simplify mixed numbers.

Fractions
CHAPTER 3



How many pies are there?

MIXED NUMBERS
LESSON 1

IN
FOCUS

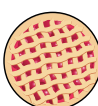
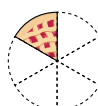
What is the fraction shown?

61
CHAPTER 3
OXFORD UNIVERSITY PRESS

IN



FOCUS

Allow pupils to relate their prior knowledge on fractions. Using the pie illustrated in In Focus and ask:

- What fraction of the pie do you see (pointing at the single wedge of pie)?
- How do we represent fractions that are greater than one whole?
- How do we represent all the pie shown in fraction?

LET'S LEARN

1. This is 1 whole pie and 1 sixth of a similar pie.

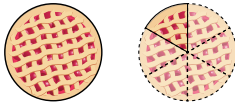

We can represent 1 whole and 1 sixth as a **mixed number**.

$$1 + \frac{1}{6} = 1\frac{1}{6}$$

There are $1\frac{1}{6}$ pies altogether.

When we add a whole number to a fraction, we will get a mixed number.



2.

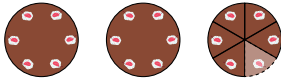

There are 2 wholes and 5 sixths of a cake. We can also represent 2 wholes and 5 sixths as a mixed number.

$$2 + \frac{5}{6} = 2\frac{5}{6}$$

There are $2\frac{5}{6}$ cakes altogether.

3. How many litres of water are there altogether?



$$3 + \frac{7}{10} = 3\frac{7}{10}$$

There is $3\frac{7}{10}$ l of water altogether.

OXFORD UNIVERSITY PRESS

FRACTIONS

62

Textbook 4 P62

For Let's Learn 1, point to the whole pie and ask the pupils how much pie that is. Then point to the single wedge of pie and ask the pupils what fraction of the pie that is. Go through the concept that $1 + \frac{1}{6} = 1\frac{1}{6}$.

Highlight that $1\frac{1}{6}$ is a mixed number and it is made up of a whole number and a fraction. Its value is greater than 1 whole.

For Let's Learn 2, ask:

- How many whole cakes are there?
- What fraction of the cake does the five slices represent?

Then go through the steps and highlight the whole and the fraction part of the mixed number.

For example 3, relate it to our everyday examples of mixed numbers including measurements (kg, l, m etc).

Ask:

- How many l of water are there altogether in the first three beakers?
- What fraction of a l are there in the last beaker?

Hence, $3 + \frac{7}{10} = 3\frac{7}{10}$ l

4. What are the mixed numbers shown?



$$3 + \frac{1}{2} = 3\frac{1}{2}$$

3 wholes and 1 half is $3\frac{1}{2}$.

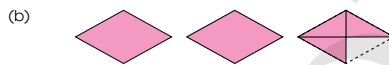

$$2 + \frac{3}{4} = 2\frac{3}{4}$$

2 wholes and 3 quarters is $2\frac{3}{4}$.

5. Fractions and mixed numbers can be represented on a number line.

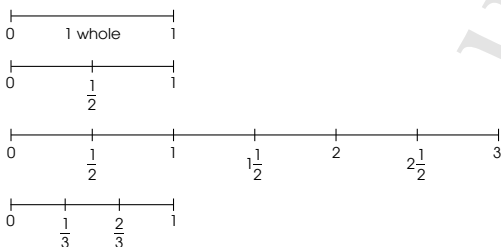

What are the missing numbers in the number line?

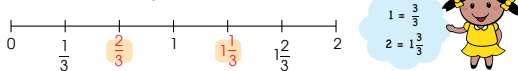

63

CHAPTER 3

OXFORD UNIVERSITY PRESS

Textbook 4 P63

For Let's Learn 4(a) & (b), show pupils that mixed numbers can also be represented with shapes/bars of equal parts. Allow pupils to solve the sums before going through them. Teacher can also get pupils to show mixed numbers using other shapes to demonstrate their understanding.

For Let's Learn 5, demonstrate how mixed numbers are represented on a number line. Remind pupils to count the number of gaps between two nearest whole numbers in order to know what fraction each little marking represents. Work through the example with the pupils.

6. What fraction does each letter represent?

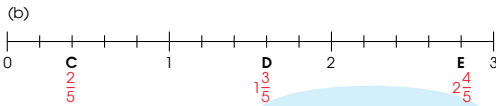
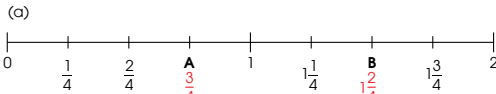

7. (a) Simplify the fraction shown.

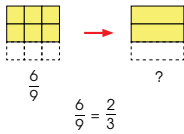

We simplify the fraction by dividing the numerator and the denominator by a common factor.

A common factor of 6 and 9 is 3.



(b) We can also express a mixed number in its simplest form.

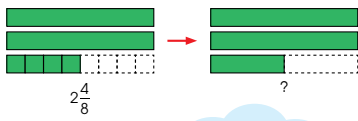

A common factor of 4 and 8 is 4.



Textbook 4 P64

For example 6(a), get pupils to explain how we can ascertain that the number line is divided into quarters. Then recite the fraction of each marking with the class starting from zero. Select a pupil to write the answer for A and B on the board.

Get pupils to work on example 6(b), before working through the answers with the class.

Review what pupils have learnt in equivalent fractions (Grade Three) and common factors (Chapter 2). Using Let's Learn 7(a) and (b) demonstrate the concept of equivalent fractions and guide pupils to see that fraction can be simplified by dividing both the numerator and the denominator by the same whole number (common factor).

8. Express each mixed number in its simplest form.

(a) $2\frac{6}{9} = 2\frac{2}{3}$

(b) $1\frac{4}{12} = 1\frac{1}{3}$

(c) $5\frac{8}{10} = 5\frac{4}{5}$

(d) $3\frac{2}{8} = 3\frac{1}{4}$

Work in pairs.

- Shuffle the $2\frac{3}{4}$.
- Pick a card and use $\frac{1}{2}$ to show the mixed number.
- Get your partner to check your answer.

ACTIVITY TIME

What you need:



- Take turns and repeat 1 and 2.

Textbook 4 P65

For Let's Learn 8, allow pupils to work out the answers before going through with the class. Reinforce the concept 'common factor' in the process.

Assign pupils to work in pairs. The activity aims to reinforce their understanding of mixed numbers with the use of fraction discs.

ACTIVITY TIME



1. What is the mixed number shown?

(a)

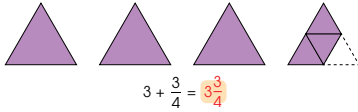

(b)

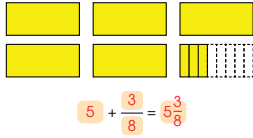

2. Find the missing mixed numbers in the number line.

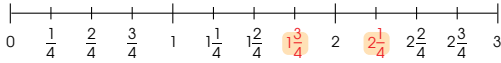

3. Find the mixed numbers represented by each letter.

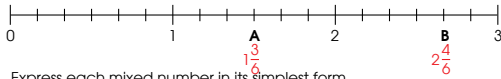

4. Express each mixed number in its simplest form.

(a) $3\frac{5}{10} = 3\frac{1}{2}$

(b) $2\frac{4}{6} = 2\frac{2}{3}$

(c) $1\frac{9}{12} = 1\frac{3}{4}$

(d) $5\frac{8}{12} = 5\frac{2}{3}$

Complete Workbook 4A, Worksheet 1 • Pages 59 – 62



Allow pupils to work in pairs or group first before going through the practice questions.

Independent seatwork

Assign pupils to complete Worksheet 1 (Workbook 4A P59 – 62).

Answers Worksheet 1 (Workbook 4A P59 – 62)

1. (a) $3\frac{1}{3}$
 (b) $3\frac{5}{8}$

2. (a) $2\frac{1}{2}$
 (b) $1\frac{1}{5}$
 (c) $7\frac{1}{2}$
 (d) $1\frac{4}{5}$

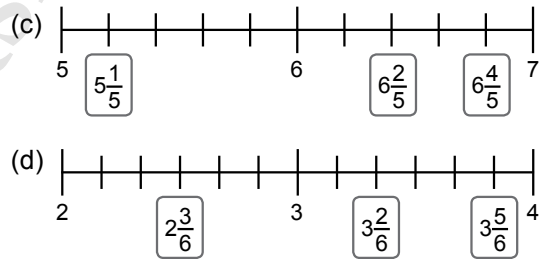
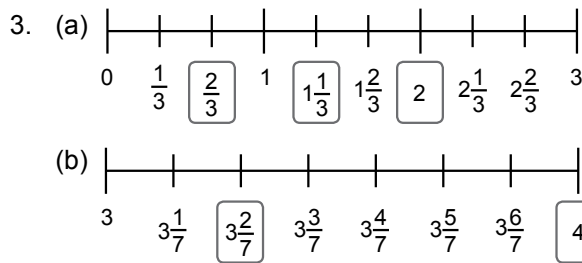

4. (a) $1\frac{2}{5}$
 (b) $2\frac{3}{4}$
5. (a) $7\frac{1}{2}$
 (b) $4\frac{1}{4}$
 (c) $5\frac{2}{3}$
 (d) $2\frac{3}{5}$
 (e) $3\frac{5}{6}$

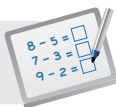

Specific Learning Focus

- Write mixed numbers.
- Simplify mixed numbers.

Suggested Duration

2 periods

Prior Learning

Pupils should be well-versed with fractions, where they should be familiar with the whole and part concepts of fractions.

Pre-emptive Pitfalls

Lesson 1 is a conceptual lesson where fraction as a whole and parts of a whole are revisited. Through the spiral approach, equivalent fractions are revisited.

Introduction

Introduce 'mixed number' as a combination of a whole number and a fraction. Let's Learn 1 to 7 (Textbook 4 P62 – 64) emphasise that a fraction represents parts of a whole. A mixed number can be represented using shapes or bars divided into equal parts. It can also be represented on a number line (Textbook 4 P63 – 64), which is divided into equal intervals.

Problem Solving

A mixed number can sometimes be reduced to its simplest form. If both the numerator and denominator are divisible by a common factor, the mixed number can be expressed in its simplest form. It is important to emphasise that the value represented by the simplest form is the same as the original mixed number before simplifying. The concept of equivalent fractions is to be revisited when reducing fractions to their simplest form.

Activities

Get pupils to work in pairs. Get each pair to take turns to represent the mixed number by using fraction discs. Provide each pair with a set of fraction cards and fraction discs.

Resources

- fraction discs (Activity Handbook 4 P13)
- fraction cards
- fraction bars (Activity Handbook 4 P14)

Mathematical Communication Support

Verbalise the questions in 'Practice' (Textbook 4 P66) on the board. Help pupils understand mixed numbers by drawing whole shapes and shapes divided into equal parts. Show mixed numbers on a number line and discuss the value of each equal interval. Key terms like 'part', 'whole', 'equivalent', 'simplest form', 'factors' and 'mixed numbers' need to be highlighted and emphasised.

IMPROPER FRACTIONS

LEARNING OBJECTIVES

1. Write improper fractions.
2. Simplify improper fractions.

IMPROPER FRACTIONS

LESSON
2

IN FOCUS



How many waffles are there?

LET'S LEARN

1.



$$\frac{1}{4} + \frac{1}{4} + \frac{1}{4} + \frac{1}{4} + \frac{1}{4} = \frac{5}{4}$$

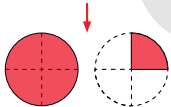

$$\begin{aligned} \frac{5}{4} &= \frac{4}{4} + \frac{1}{4} \\ &= 1\frac{1}{4} \end{aligned}$$

$\frac{5}{4}$ is an improper fraction.

Improper fractions are fractions where the numerator is greater than or equal to the denominator.

There are $\frac{5}{4}$ or 5 quarters of a waffle.

IN FOCUS

Get pupils to review their earlier lessons on mixed numbers. Using the example featured in the In Focus, ask pupils to try piecing the wedges of waffles together to form as many wholes as possible using fraction discs. Then ask pupils to express how many waffles there are altogether using a mixed number. Explain that we can also represent the number of waffles using improper fraction.

LET'S LEARN

For Let's Learn 1, guide pupils through the example to see that five $\frac{1}{4}$ s gives $\frac{5}{4}$ which is equivalent to $1\frac{1}{4}$. Introduce improper fraction as a fraction where the numerator is greater than or equal to the denominator.

2. What is the fraction shown?

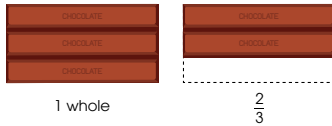

There are 1 whole and 2 thirds.

$$\begin{aligned} 1 \text{ whole} &= 3 \text{ thirds} \\ &= \frac{3}{3} \\ 1\frac{2}{3} &= \frac{3}{3} + \frac{2}{3} \\ &= \frac{5}{3} \end{aligned}$$

How many thirds are there in 1 whole?



3. Write the improper fraction for each of the following.



There are 1 whole and 3 fifths.

$$\begin{aligned} 1 \text{ whole} &= \frac{5}{5} \\ 1\frac{3}{5} &= \frac{5}{5} + \frac{3}{5} \\ &= \frac{8}{5} \end{aligned}$$

OXFORD UNIVERSITY PRESS

FRACTIONS 68

Textbook 4 P68

Work through Let's Learn 2, reinforce that 3 thirds make a whole and it can be represented by the fraction $\frac{3}{3}$. So $\frac{3}{3} + \frac{2}{3} = \frac{5}{3}$ (3 thirds + 2 thirds = 5 thirds) which is equal to $1\frac{2}{3}$.

Guide pupils through Let's Learn 3(a) slowly and prompt the class for answers for each blank. Then give pupils sufficient time to work through 3(b) and (c) before going through with the class.

(b)

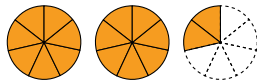

There are 16 sevenths.

The fraction shown is $\frac{16}{7}$.

(c)

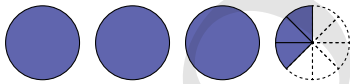

There are 27 eighths.

The fraction shown is $\frac{27}{8}$.

4. Improper fractions are more than or equal to 1.

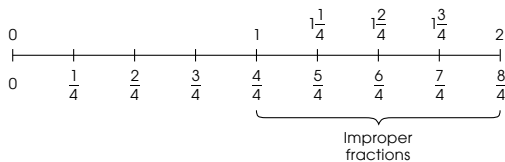

$\frac{4}{4}$, $\frac{5}{4}$, $\frac{6}{4}$, $\frac{7}{4}$ and $\frac{8}{4}$ are improper fractions.

69 CHAPTER 3

OXFORD UNIVERSITY PRESS

Textbook 4 P69

For Let's Learn 4, review representing mixed numbers on a number line. Then guide pupils to recite the improper fraction represented by each marking after 1 whole.

5. What are the missing improper fractions?

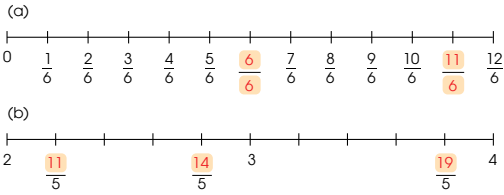

6. Express the improper fraction shown in its simplest form.

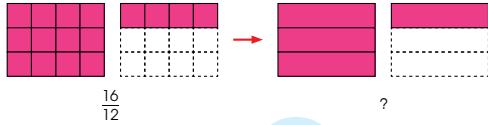

$$\frac{16}{12}$$

$$\frac{16}{12} = \frac{4}{3}$$

4 is a common factor of 12 and 16.

$$\frac{16}{12} = \frac{4}{3}$$



7. Express each improper fraction in its simplest form.

(a) $\frac{26}{4} = \frac{13}{2}$

(b) $\frac{15}{6} = \frac{5}{2}$

(c) $\frac{24}{10} = \frac{12}{5}$

(d) $\frac{30}{8} = \frac{15}{4}$

OXFORD UNIVERSITY PRESS

FRACTIONS 70

Textbook 4 P70

Guide the class to fill in the missing improper fractions in Let's Learn 5(a).

For Let's Learn 5(b), ask pupils what the improper fraction for 2 wholes is. If necessary, extend the number line to the left to show the markings from 1 whole to 2 wholes. Have the class recite the improper fractions for each marking and get them to write down the answers.

For Let's Learn 6, review the earlier lessons on simplifying fractions and mixed numbers. Then ask pupils what the common factors of the numerator and denominator are. Guide pupils through the example to simplify the improper fraction.

For Let's Learn 7, give pupils sufficient time to work through the example before going through.

Work in pairs.

1 Shuffle the $\frac{5}{2}$.

Pick a card.

2 Use $\frac{5}{2}$ to show the fraction on your card.

Get your partner to check your answer.

3 Take turns and repeat 1 and 2.

ACTIVITY TIME

What you need:



PRACTICE

1. What is the improper fraction shown?



There are 7 fifths.

The fraction shown is $\frac{7}{5}$.

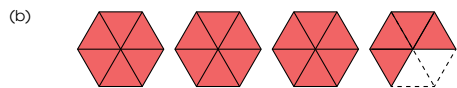

There are 22 sixths.

The fraction shown is $\frac{22}{6}$.

71 CHAPTER 3

OXFORD UNIVERSITY PRESS

Textbook 4 P71

ACTIVITY TIME

The activity helps pupils translate abstract improper fractions into concrete representation using fraction discs.

PRACTICE

Allow pupils to work in pairs. Give pupils sufficient time to work through the practice before going through.

Independent seatwork

Assign pupils to complete Worksheet 2 (Workbook 4A P63 – 66).

(c)

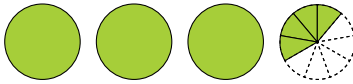

There are 31 ninths.

The fraction shown is $\frac{31}{9}$.

2. What are the missing improper fractions?

(a)

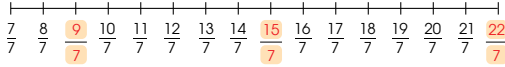

(b)

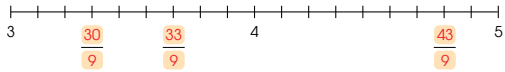

3. Express each improper fraction in its simplest form.

(a) $\frac{22}{10} = \frac{11}{5}$

(b) $\frac{18}{12} = \frac{3}{2}$

(c) $\frac{26}{8} = \frac{13}{4}$

(d) $\frac{21}{6} = \frac{7}{2}$

Complete Workbook 4A, Worksheet 2 • Pages 63 – 66

OXFORD UNIVERSITY PRESS

FRACTIONS

72

Textbook 4 P72

Answers Worksheet 2 (Workbook 4A P63 – 66)

1. (a) There are 7 quarters.
The improper fraction shown is $\frac{7}{4}$.
- (b) There are 12 fifths.
The improper fraction shown is $\frac{12}{5}$.
- (c) There are 19 sixths.
The improper fraction shown is $\frac{19}{8}$.
- (d) There are 11 sevenths.
The improper fraction shown is $\frac{11}{7}$.
- (e) There are 19 eighths.
The improper fraction shown is $\frac{19}{8}$.

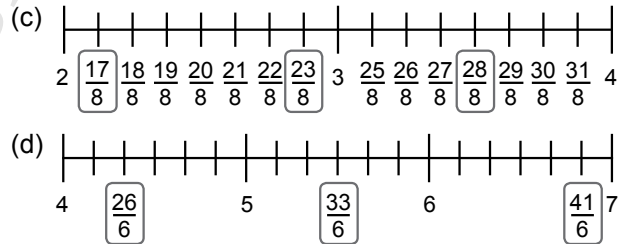
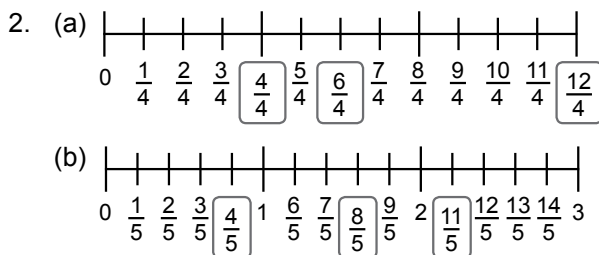

3. (a) $\frac{5}{2}$
(b) $\frac{7}{5}$
4. (a) $\frac{11}{2}$
(b) $\frac{16}{3}$
(c) $\frac{9}{2}$
(d) $\frac{9}{2}$
(e) $\frac{7}{2}$

**Specific Learning Focus**

- Write improper fractions.
- Simplify improper fractions.

Suggested Duration

2 periods

Prior Learning

This lesson is an extension of earlier lessons on mixed numbers. Pupils should be well-versed with pictorial and mathematical representations of fractions.

Pre-emptive Pitfalls

Improper fractions should not be difficult to understand as the concept can be explained with the help of concrete materials and visual experiences.

Introduction

Explain that improper fraction is a fraction where the numerator is greater than or equal to the denominator. In fact, the term itself is self-explanatory as proper fractions are fractions where the numerator is smaller than the denominator. In Let's Learn 1 (Textbook 4 P67), $\frac{5}{4}$ can be split into $\frac{4}{4}$ and $\frac{1}{4}$, using fraction discs or number bonds. Converting mixed numbers into improper fractions is shown in Let's Learn 2 (Textbook 4 P68). Give other examples of converting mixed numbers into improper fractions (e.g. $1\frac{3}{5} = \frac{5}{5} + \frac{3}{5} = \frac{8}{5}$, where $\frac{5}{5} = 1$).

Problem Solving

Explain that similar to mixed number, improper fraction can also be reduced to its simplest form by identifying the common factor of the numerator and denominator.

Activities

'Activity Time' (Textbook 4 P71) is similar to the one in Lesson 1. Provide pupils with improper fraction cards and fraction discs.

Resources

- improper fraction cards (Activity Handbook 4 P15 – 16)
- fraction discs (Activity Handbook 4 P13)

Mathematical Communication Support

Verbalise, discuss and visualise using shapes, bars and number lines when going through the questions in 'Practice' (Textbook 4 P71 – 72). Encourage individual responses and ask pupils to draw on the board the shape that they would like to use to show the improper fraction.

CONVERTING FRACTIONS

LEARNING OBJECTIVE

1. Convert between mixed numbers and improper fractions.

CONVERTING FRACTIONS

LESSON
3

IN  FOCUS

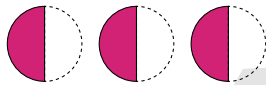

The improper fraction shown is $\frac{3}{2}$.

How can you change it to a mixed number?

LET'S LEARN 

1. There are 3 shaded halves.
2 shaded halves make 1 whole.

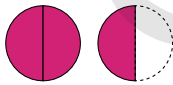

There are 1 whole and 1 half.

$$\begin{aligned} \frac{3}{2} &= \frac{1}{2} + \frac{1}{2} + \frac{1}{2} \\ &= \frac{2}{2} + \frac{1}{2} \\ &= 1 + \frac{1}{2} \\ &= 1\frac{1}{2} \end{aligned}$$

The mixed number is $1\frac{1}{2}$.

73 CHAPTER 3

OXFORD
UNIVERSITY PRESS

IN  FOCUS

Ask pupils what fraction of the circle is shaded.
Get pupils to express their answer in mixed number
and improper fraction.

LET'S LEARN 

With the aid of the diagram in Let's Learn 1, guide pupils
to see that $\frac{3}{2}$ is the same as $1 + \frac{1}{2}$ and finally that $\frac{3}{2} = 1\frac{1}{2}$.

Textbook 4 P73

2. Change $\frac{7}{3}$ to a mixed number.

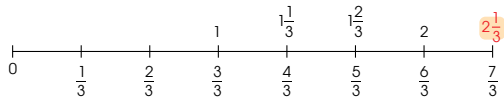

$$\begin{aligned}\frac{7}{3} &= \frac{3}{3} + \frac{3}{3} + \frac{1}{3} \\ &= 1 + 1 + \frac{1}{3} \\ &= 2 + \frac{1}{3} \\ &= 2\frac{1}{3}\end{aligned}$$

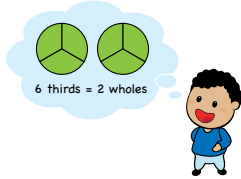

We can also change it this way.

$$\begin{aligned}\frac{7}{3} &= \frac{6}{3} + \frac{1}{3} \\ &= 2 + \frac{1}{3} \\ &= 2\frac{1}{3}\end{aligned}$$

3. Change $\frac{10}{6}$ to a mixed number.
Express it in its simplest form.

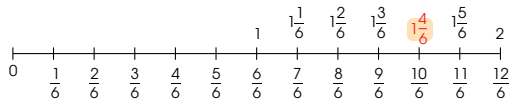

OXFORD
UNIVERSITY PRESS

FRACTIONS 74

Textbook 4 P74

For Let's Learn 2, show the class using fraction discs that $\frac{7}{3} = \frac{3}{3} + \frac{3}{3} + \frac{1}{3}$. Guide pupils through each step to finally ascertain that $\frac{7}{3} = 2\frac{1}{3}$.

For Let's Learn 3, work through step-by-step and prompt the class for the answers to each blank. Remind pupils to express their answer in the simplest form.

$$\begin{aligned}\frac{10}{6} &= \frac{6}{6} + \frac{4}{6} \\ &= 1 + \frac{4}{6} \\ &= 1\frac{2}{3}\end{aligned}$$

4. Change each of the following to a mixed number.
Express each mixed number in its simplest form.

(a) $\frac{16}{7} = 2\frac{2}{7}$

(b) $\frac{30}{9} = 3\frac{1}{3}$

5. Change $2\frac{3}{4}$ to an improper fraction.



1 whole = 4 quarters
2 whole = 4 quarters \times 2
= 8 quarters
8 + 3 = 11

There are 11 quarters altogether.

$$2\frac{3}{4} = \frac{11}{4}$$

$$\begin{aligned}2\frac{3}{4} &= 1 + 1 + \frac{3}{4} \\ &= \frac{4}{4} + \frac{4}{4} + \frac{3}{4} \\ &= \frac{11}{4}\end{aligned}$$



75 CHAPTER 3

OXFORD
UNIVERSITY PRESS

Textbook 4 P75

For Let's Learn 4, give pupils sufficient time to work through the solutions before going through. If necessary, allow pupils to use fraction discs to find the answers.

For Let's Learn 5, use fraction discs to illustrate $2\frac{3}{4}$. Guide pupils to see that 1 whole is made up of four quarters and 2 wholes is equal to 8 quarters. Finally add up the number of quarters. Fraction discs can be distributed to pupils to help them visualise each step.

6. Change each mixed number to an improper fraction.

(a) $3\frac{2}{3} = \frac{11}{3}$

(b) $5\frac{7}{8} = \frac{47}{8}$

(c) $4\frac{1}{2} = \frac{9}{2}$

(d) $2\frac{4}{5} = \frac{14}{5}$

ACTIVITY **TIME**

Play in groups of 4.

1 Shuffle the .

Distribute all the cards among the players.

2 Shuffle the .

Place them face down on the table.

3 Take turns to turn over a .

4 Match the with the correct .

The first player to match the correct card leaves the card on the table.

5 Repeat 3 and 4.

The first player with no cards left wins!

What you need:

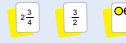

Textbook 4 P76

Allow pupils to work in groups or pairs to solve Let's Learn 6(a) to 6(d) before working through with the class.

ACTIVITY **TIME**

Play in groups of 4. The activity helps pupils translate abstract mixed numbers and improper fractions to pictorial representation.

1 Go to <http://www.shinglee.com.sg/StudentResources/NSPM4>.

2 Click on "Match Them Up".

3 Click on the matching pairs of improper fractions and mixed numbers in 2 minutes.

Can you match all pairs in 2 minutes?



PRACTICE

1. Change each improper fraction to a mixed number. Express each mixed number in its simplest form.

(a) $\frac{23}{4} = 5\frac{3}{4}$

(b) $\frac{35}{2} = 17\frac{1}{2}$

(c) $\frac{50}{6} = 8\frac{1}{3}$

(d) $\frac{62}{8} = 7\frac{3}{4}$

2. Change each mixed number to an improper fraction.

(a) $5\frac{2}{9} = \frac{47}{9}$

(b) $6\frac{5}{12} = \frac{77}{12}$

(c) $9\frac{3}{8} = \frac{75}{8}$

(d) $12\frac{2}{3} = \frac{38}{3}$

Complete Workbook 4A, Worksheet 3 + Pages 67 – 70

Textbook 4 P77

ACTIVITY **TIME**

The digital game provides fun exercises for pupils to consolidate the conversion between improper fractions and mixed numbers.

PRACTICE

Allow pupils to work in pairs. Give pupils sufficient time to work through the practice before going through them.

Independent seatwork

Assign pupils to complete Worksheet 3 (Workbook 4A P67 – 70).

1. (a) $1\frac{3}{4} = \frac{7}{4}$
(b) $2\frac{2}{3} = \frac{8}{3}$
(c) $3\frac{5}{8} = \frac{29}{8}$
2. (a) $2\frac{2}{3}$
(b) $2\frac{1}{2}$
3. (a) $2\frac{1}{3}$
(b) $1\frac{4}{5}$
(c) $1\frac{4}{7}$
(d) $3\frac{2}{4} = 3\frac{1}{2}$
(e) $2\frac{2}{10} = 2\frac{1}{5}$
4. (a) $\frac{34}{7}$
(b) $\frac{20}{3}$
(c) $\frac{35}{6}$
(d) $\frac{37}{5}$
(e) $\frac{51}{8}$

OXFORD
UNIVERSITY PRESS

COMPARING AND ORDERING FRACTIONS

LEARNING OBJECTIVE

1. Compare and order fractions.

COMPARING AND ORDERING FRACTIONS

LESSON
4

IN FOCUS

Nora has $1\frac{2}{3}$ of a cake.
Sam has $1\frac{1}{2}$ of a similar cake.
Who has less cake?



LET'S LEARN

1. Which is smaller, $1\frac{2}{3}$ or $1\frac{1}{2}$?

Since the whole numbers are the same, we compare the fractions.



The first common multiple of 2 and 3 is 6.

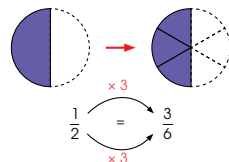
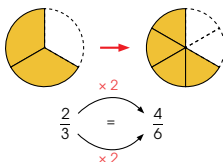

IN FOCUS

Pose the question to the pupils; allow them to use fraction discs to compare. Then ask the pupils how we can compare two mixed numbers with different denominators without using fraction discs.

LET'S LEARN

For Let's Learn 1, highlight that both mixed numbers have the same whole number so we compare the fraction. Using fraction discs, illustrate the equivalent fraction of $\frac{2}{3}$ and $\frac{1}{2}$. Without the manipulative, guide pupils to convert the fractions to their equivalent fractions with a common denominator. Show pupils how they can either make a systematic list of the equivalent fractions or find the common multiple of the two denominators.

We can also use a number line to compare the fractions.

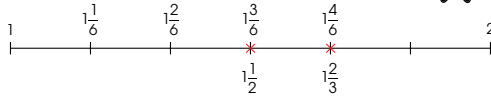

$1\frac{1}{2}$ is smaller than $1\frac{2}{3}$.

2. Which is greater, $1\frac{5}{8}$ or $1\frac{3}{4}$?

We can use equivalent fractions to compare $1\frac{5}{8}$ and $1\frac{3}{4}$.

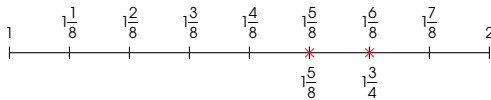
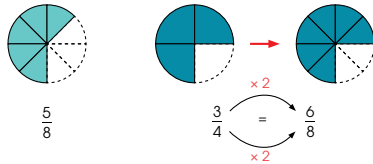

$1\frac{3}{4}$ is greater than $1\frac{5}{8}$.

Textbook 4 P79

3. Compare the fractions.

Use  or a number line to compare.

(a) Which is greater, $2\frac{1}{3}$ or $2\frac{5}{12}$? $2\frac{5}{12}$

(b) Which is smaller, $3\frac{3}{4}$ or $3\frac{2}{3}$? $3\frac{2}{3}$

4. Which is smaller, $\frac{11}{4}$ or $\frac{15}{8}$?

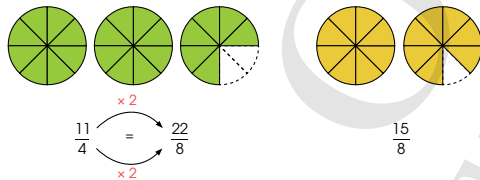

$\frac{15}{8}$ is smaller than $\frac{22}{8}$.

So, $\frac{15}{8}$ is smaller than $\frac{11}{4}$.

5. Compare the fractions.

Use  or a number line to compare.

(a) Which is greater, $\frac{10}{3}$ or $\frac{15}{9}$? $\frac{10}{3}$

(b) Which is smaller, $\frac{9}{4}$ or $\frac{13}{6}$? $\frac{13}{6}$

Textbook 4 P80

After converting the fractions to their equivalent fraction with the same denominator, guide pupils to use the number line to compare.

Let's Learn 2 involves the comparison of two related mixed numbers. Lead pupils to see that the denominator of one fraction is a multiple of the denominator of the other fraction (4 and 8). Demonstrate the process of converting $\frac{3}{4}$ to $\frac{6}{8}$. After that, use the number line to compare.

Allow pupils to work in pairs using fraction discs for Let's Learn 3. Then work through the solutions with the class.

For Let's Learn 4, recap with pupils the process of comparing two related fractions. Guide pupils to see that they have to convert $\frac{11}{4}$ to its equivalent fraction with a denominator of 8. Demonstrate the steps of converting $\frac{11}{4}$ to $\frac{22}{8}$. Then ask the class if they can think of other methods to compare.

Allow pupils to work in pairs for Let's Learn 5. Encourage them to use different methods to compare. After that, demonstrate the process to the class.

6. Which is greater, $\frac{13}{5}$ or $2\frac{7}{10}$?

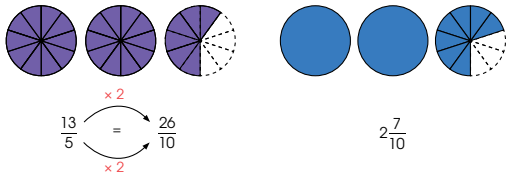

We can compare by converting the mixed number into an improper fraction.

$$2\frac{7}{10} = \frac{27}{10}$$

$\frac{27}{10}$ is greater than $\frac{26}{10}$.

So, $2\frac{7}{10}$ is greater than $\frac{13}{5}$.

We can also compare by converting the improper fraction into a mixed number.

$$\frac{13}{5} = \frac{26}{10} = 2\frac{6}{10}$$

$\frac{7}{10}$ is greater than $\frac{6}{10}$.

So, $2\frac{7}{10}$ is greater than $\frac{13}{5}$.

7. Compare the fractions.

Use or a number line to compare.

(a) Which is greater, $\frac{13}{9}$ or $1\frac{2}{3}$? $1\frac{2}{3}$

(b) Which is smaller, $2\frac{5}{6}$ or $1\frac{1}{4}$? $1\frac{1}{4}$

Textbook 4 P81

8. Arrange $\frac{9}{5}$, $1\frac{1}{10}$ and $1\frac{3}{10}$ in increasing order.

Use or a number line to compare.

$1\frac{1}{10}$ is smaller than $1\frac{3}{10}$.
Compare $1\frac{3}{10}$ and $\frac{9}{5}$.



$$\frac{9}{5} = 1\frac{4}{5} = 1\frac{8}{10}$$

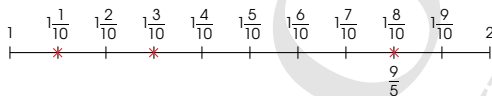

$1\frac{1}{10}$ is the smallest.

$\frac{9}{5}$ is the greatest.

Arranging the fractions in increasing order, we have

$$1\frac{1}{10}, 1\frac{3}{10}, \frac{9}{5}$$

9. Arrange $\frac{19}{6}$, $2\frac{11}{12}$, 2 and $\frac{8}{3}$ in decreasing order.

Use or a number line to compare.

Convert the improper fractions into mixed numbers.

$$\frac{19}{6} = 3\frac{1}{6}$$

$$\frac{8}{3} = 2\frac{2}{3}$$

Textbook 4 P82

Let's Learn 6 involves the comparison of an improper fraction and a mixed number. First, review with pupils the different methods of comparing two fractions. After that, demonstrate the process of comparing by converting the mixed number to improper fraction. Then demonstrate the process of comparing by converting the improper fraction into a mixed number.

For Let's Learn 7, allow pupils to spend some time comparing the fractions using either fraction discs or number lines before working through the process.

Let's Learn 8 involves comparing and ordering three fractions. Review with the pupils the different methods learnt. Pose this question to the class: which two fractions should be compared first? ($1\frac{1}{10}$ and $1\frac{3}{10}$).

Upon establishing that $1\frac{1}{10}$ is smaller, guide the class to compare $1\frac{3}{10}$ and $\frac{9}{5}$. Finally using the number line guide pupils through the process of ordering the numbers.

For Let's Learn 9, allow pupils to work in groups or pairs. Encourage pupils to examine the type of fraction given. They can compare two fractions at a time to find the greater fraction. Guide pupils through the process.

Hint:

- Convert the improper fractions to mixed numbers to compare the whole numbers. (Pupils should be able to ascertain that 2 is the smallest and $\frac{19}{6}$ is the largest).
- Compare the two remaining fractions. (Encourage pupils to use the different methods learnt to compare.)

Then work through the solution with the class.

Work in pairs. The activity help pupils consolidate what they have learnt in comparing and ordering fractions.

Comparing the whole numbers, 2 is the smallest.

$2\frac{11}{12}$ and $\frac{8}{3}$ are smaller than $\frac{19}{6}$.
So, $\frac{19}{6}$ is the greatest.

Compare $2\frac{11}{12}$ and $\frac{8}{3}$.

$$\frac{8}{3} = 2\frac{2}{3} = 2\frac{8}{12}$$

$2\frac{11}{12}$ is greater than $\frac{8}{3}$.

Arranging the fractions in decreasing order, we have

$$\frac{19}{6}, 2\frac{11}{12}, \frac{8}{3}, 2$$

ACTIVITY  TIME

Work in pairs.

- 1 Shuffle the .
- 2 Pick two cards and place them in the correct order on a number line.
- 3 Get your partner to check if the fractions are in the correct order.
- 4 Switch roles and repeat 1 to 3.

What you need:



PRACTICE 

1. Which fraction is greater?

(a) $3\frac{5}{9}$ or $3\frac{2}{9}$ $3\frac{5}{9}$

(b) $2\frac{2}{5}$ or $2\frac{1}{2}$ $2\frac{1}{2}$

(c) $\frac{8}{3}$ or $\frac{5}{2}$ $\frac{8}{3}$

(d) $\frac{9}{4}$ or $\frac{7}{6}$ $\frac{9}{4}$

(e) $4\frac{3}{5}$ or $\frac{25}{2}$ $\frac{25}{2}$

(f) $3\frac{1}{4}$ or $\frac{10}{3}$ $\frac{10}{3}$

2. Which fraction is smaller?

(a) $2\frac{5}{6}$ or $2\frac{3}{4}$ $2\frac{3}{4}$

(b) $3\frac{7}{10}$ or $3\frac{3}{5}$ $3\frac{3}{5}$

(c) $\frac{16}{7}$ or $\frac{18}{7}$ $\frac{16}{7}$

(d) $\frac{31}{6}$ or $\frac{21}{4}$ $\frac{31}{6}$

(e) $5\frac{5}{9}$ or $\frac{43}{9}$ $\frac{43}{9}$

(f) $1\frac{9}{10}$ or $\frac{9}{5}$ $\frac{9}{5}$

3. Arrange the fractions in increasing order.

(a) $2\frac{1}{6}, \frac{7}{2}, \frac{17}{6}, 2\frac{1}{6}, \frac{17}{6}, \frac{7}{2}$

(b) $3\frac{4}{5}, 3, \frac{13}{5}, 2\frac{1}{3}, 2\frac{1}{3}, \frac{13}{5}, 3, 3\frac{4}{5}$

4. Arrange the fractions in decreasing order.

(a) $4\frac{1}{4}, \frac{32}{7}, 4\frac{2}{7}, \frac{32}{7}, 4\frac{2}{7}, 4\frac{1}{4}$

(b) $\frac{50}{9}, 5, \frac{9}{2}, 5\frac{4}{9}, \frac{50}{9}, 5\frac{4}{9}, 5, \frac{9}{2}$

Complete Workbook 4A, Worksheet 4 • Pages 71 – 74

PRACTICE 

Work with pupils on the practice questions. For each question, ask pupils to decide which method is the most appropriate. Invite pupils to show their working on the board. Get the class to check and identify errors.

Independent seatwork

Assign pupils to complete Worksheet 4 (Workbook 4A P71 – 74).

1. (a) $\frac{5}{8}$ is smaller than $\frac{3}{4}$.
(b) $\frac{3}{10}$ is smaller than $\frac{2}{5}$.
(c) $\frac{2}{3}$ is greater than $\frac{7}{12}$.
(d) $\frac{5}{6}$ is greater than $\frac{3}{4}$.

2. $\frac{1}{3}, \frac{1}{2}, \frac{5}{6}$

3. $\frac{3}{4}, \frac{2}{3}, \frac{2}{12}$

4. (a) $2\frac{3}{4}$ is greater than $2\frac{7}{12}$.
(b) $3\frac{2}{3}$ is greater than $3\frac{1}{2}$.

5. (a) $2\frac{2}{5}$ is smaller than $3\frac{2}{3}$.
(b) $3\frac{3}{4}$ is smaller than $3\frac{5}{6}$.

6. (a) $\frac{8}{3}$ is greater than $\frac{9}{2}$.
(b) $\frac{21}{5}$ is smaller than $\frac{5}{2}$.

7. (a) greater
(b) greater

8. (a) $1\frac{1}{2}, \frac{7}{4}, \frac{5}{2}$
(b) $2\frac{9}{10}, 3, 3\frac{1}{10}, \frac{16}{5}$

9. (a) $\frac{17}{5}, 2\frac{2}{3}, 2\frac{3}{5}$
(b) $2\frac{1}{3}, \frac{20}{9}, 2, \frac{5}{3}$

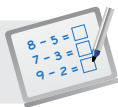
**Specific Learning Focus**

- Convert between mixed numbers and improper fractions.
- Compare and order fractions.

Suggested Duration

Lesson 3: 2 periods

Lesson 4: 2 periods

Prior Learning

Lessons 3 and 4 are extensions of the earlier lessons. The concept of equivalent fractions taught in the earlier grade is also revisited when reducing a fraction to its simplest form and changing unlike fractions to like fractions.

Pre-emptive Pitfalls

Since multiple strategies are employed, pupils need to be engaged through manipulatives and visualisation.

Introduction

While converting improper fraction into mixed number, fraction discs and number lines can be used. Work through Let's Learn 2 (Textbook 4 P74) step by step, by showing the number of wholes and the fraction that the improper fraction is made up of. In lesson 4, first convert the fractions into like fractions (common denominator). Once this is done, since the whole numbers are the same, the numerators of the like fractions are compared and then the fractions are arranged in the order stated in the question.

Problem Solving

From Let's Learn 6 (Textbook 4 P81) onwards, the set of fractions consists of both improper and mixed numbers. Explain that in order to compare the fractions, all fractions should be in the improper form. Then, if the denominators of the fractions are different, the lowest common multiple among the denominators are to be determined. Once all the fractions are improper and have the same denominator, they can be easily compared and arranged in order.

Activities

'In Focus' (Textbook 4 P78) and 'Activity Time' (Textbook 4 P83) can be carried out in class. These activities can be used as a formative assessment tool to gauge pupils' understanding of the topic.

Resources

- fraction cards
- fraction discs (Activity Handbook 4 P13)
- improper fraction cards (Activity Handbook 4 P17)
- mixed number cards (Activity Handbook 4 P18)

Mathematical Communication Support

Guide pupils to split mixed numbers into a whole number and a fraction. Remind pupils that a whole number is also a fraction where the numerator and denominator are the same. The questions in 'Practice' (Textbook 4 P77, 84) can be discussed in class on the board and then get pupils to work on them independently.

LEARNING OBJECTIVE

1. Fraction as part of a set of objects.

FRACTION OF A SET

LESSON
5

IN
FOCUS



What fraction of the children are boys?

LET'S LEARN

1. There are 12 children altogether.
There are 5 boys and 7 girls.



5 out of the 12 children are boys.

$\frac{5}{12}$ of the children are boys.

$\frac{5}{12}$ ← Number of boys

 ← Total number of children

85
CHAPTER 3
OXFORD UNIVERSITY PRESS

IN



FOCUS

Review with pupils the concept of fractions. Using the question from In Focus, ask pupils how they can find the answer.

LET'S LEARN

Guide pupils through Let's Learn 1, highlighting that the total number of 'objects' in the set (the total number of children) is 12, of which, 5 are boys. Hence 5 out of 12 children are boys or $\frac{5}{12}$ of the children are boys. Pictorial model may be used to help pupils understand the question.

Textbook 4 P85

2.



There are 3 red cubes.
 There are 4 yellow cubes.
 There are 7 cubes altogether.
 $\frac{3}{7}$ of the cubes are red.
 $\frac{4}{7}$ of the cubes are yellow.

3.

There are 15 cubes.
 $\frac{2}{5}$ of the cubes are green.
 How many cubes are green?

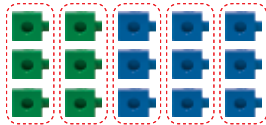

We divide the 15 cubes into 5 equal groups.
 1 group is $\frac{1}{5}$ of 15.
 2 out of 5 groups of cubes are green.
 1 group contains 3 cubes.
 2 groups contain 6 cubes.
 $\frac{2}{5}$ of 15 is 6.

Textbook 4 P86

For Let's Learn 2, guide pupils to fill in the blanks and illustrate with pictorial model to aid understanding.

For Let's Learn 3, distribute multilink cubes to the pupils. Guide pupils to see that to find $\frac{2}{5}$ of 15, we need to divide the cubes into 5 equal groups. Give pupils time to arrange the multilink cubes into 5 equal groups. Guide pupils to see that 2 out of the 5 equal groups are green. Ask pupils, how many cubes are there in 1 group (3) and then how many cubes are there in 2 groups (6).

We can find $\frac{2}{5}$ of 15 by using a model.

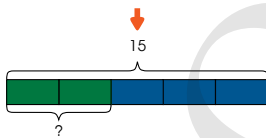
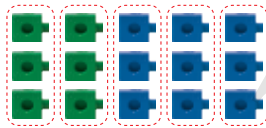

$$\begin{aligned} 5 \text{ units} &= 15 \\ 1 \text{ unit} &= 15 \div 5 \\ &= 3 \\ 2 \text{ units} &= 2 \times 3 \\ &= 6 \end{aligned}$$

1 unit stands for 3 cubes.



$\frac{2}{5}$ of 15 is 6.
 6 cubes are green.

Next, illustrate the solution using model and guide them through the steps to arrive at the answer.

Textbook 4 P87

Work in pairs.

$\frac{1}{3}$ of 12

ACTIVITY  TIME

What you need:



- 1 Use  to find the answer.
- 2 Get your partner to find the answer by drawing a model.
- 3 Find the value of each of the following.



Take turns to use  and to draw a model to find the answers.

- (a) $\frac{1}{2}$ of 24 (b) $\frac{3}{5}$ of 35 (c) $\frac{2}{7}$ of 21
 (d) $\frac{3}{4}$ of 36 (e) $\frac{5}{6}$ of 54 (f) $\frac{5}{8}$ of 40

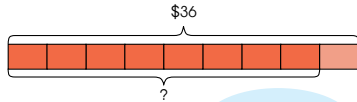
4. Priya had \$36.
 She spent $\frac{8}{9}$ of her money on a watch.
 How much did the watch cost?



9 units = \$36
 1 unit = $\$36 \div 9$
 = \$4
 8 units = $\$4 \times 8$
 = \$32

Use  or  to help you count.



The watch cost \$32.

Textbook 4 P88

The activity will help reinforce the concept and understanding of fraction of a set.

LET'S LEARN 

For Let's Learn 4, work through the solution with the class.

5. A basket contains some apples and oranges.
 $\frac{5}{12}$ of the fruits are apples.
 There are 10 apples.
 How many apples and oranges are there altogether?

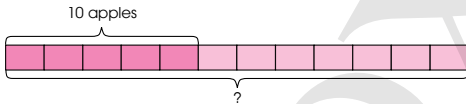

5 units = 10
 1 unit = $10 \div 5$
 = 2
 12 units = 2×12
 = 24

There are 24 apples and oranges altogether.

PRACTICE 

Solve.

1. A baker bought 40 kg of flour.
 She used $\frac{3}{8}$ of the flour to bake some bread. $40 \text{ kg} \div 8 = 5 \text{ kg}$
 How many kilograms of flour did she use? $5 \text{ kg} \times 3 = 15 \text{ kg}$
- * 2. Siti had \$45.
 She spent $\frac{1}{3}$ of her money on books and $\frac{5}{9}$ of it on stationery.
 How much money did she spend?
 $\$45 \div 3 = \15
 $\$15 \times 5 = \75
 $\$75 - \$15 = \$60$

Complete Workbook 4A, Worksheet 5 • Pages 75–78

Textbook 4 P89

Allow pupils to work in pairs to solve the problem and fill in the blanks in Let's Learn 5 before going through with the class.

PRACTICE 

Work through the practice questions with the class.

Independent seatwork

Assign pupils to complete Worksheet 5 (Workbook 4A P75 – 78).

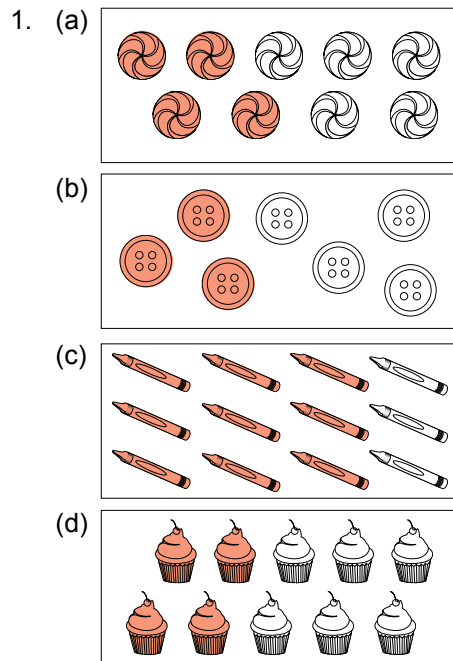

2. (a) $\frac{1}{2}$
 (b) $\frac{2}{3}$

3. $36 \div 3 = 12$
 $12 \times 2 = 24$
 There are 24 butter cookies.

4. $48 \text{ kg} \div 6 = 8 \text{ kg}$
 $8 \text{ kg} \times 5 = 40 \text{ kg}$
 40 kg of rice was sold.

5. $\$72 \div 8 = \9
 $\$72 - \$9 = \$63$
 Bina had \$63 left.

6. $42 \div 7 = 6$
 $2 \times 6 = 12$
 $42 - 12 = 30$
 There are 30 ducks.

*7. (a) $60 \times 4 = 240$
 There are 240 blue beads.
 (b) $60 \times 5 = 300$
 The total number of beads in the box is 300.



Specific Learning Focus

- Fraction as part of a set of objects.

Suggested Duration

4 periods

Prior Learning

This lesson is a continuation of the concepts of fractions taught in the earlier lessons of this chapter.

Pre-emptive Pitfalls

This lesson involves the use of real-life examples. Pupils learn to express a subject in terms of fractions (e.g. If Sam gets $\frac{1}{3}$ of Rs 1500, how much money does he get?). This is a new concept which can be explained better by relating to real-life examples. Pupils might find it difficult to relate it to the correct operation.

Introduction

Explain to pupils that a particular subject must first be expressed in the form of a fraction. This is called a fraction of a set. 'In Focus' (Textbook 4 P85) can be carried out in class. The teacher may ask pupils for the number of pupils in the class with curly hair or who wear glasses. To find the fraction of a set, the first step involves the representation of the subject as a fraction. Emphasise that the numerator represents the subject value and the denominator represents the total value. Once the fraction is found, the next step is to multiply the fraction by the actual total value to find the subject value. In Let's Learn 4 (Textbook 4 P88), using the concept of fraction of a set, the actual cost of the watch is found: $\frac{8}{9}$ of 36. 'Of' is replaced with the multiplication symbol. An alternative method to solve Let's Learn 4 is as follows:

$$\frac{8}{9} \text{ of } 36 = \frac{8}{9} \times 36 \quad (36 \text{ is the lowest common multiple of } 9 \text{ and } 4) = 8 \times 4 = \$32$$

Problem Solving

There are two parts to Question 2 in 'Practice' (Textbook 4 P89). The amounts Siti spent on the books and stationery respectively are to be found. Encourage the drawing of bar models to solve the problem. In Let's Learn 5 (Textbook 4 P89), since the denominator is 12, the bar model is divided into 12 equal parts, of which 10 out of 12 equal parts represent 10 apples.

Activities

Using the fraction of a set cards, get pupils to make sets with multilink cubes. Explain that the multilink cubes can be used to represent bar models. Alternatively, provide pupils with blank bar model strips to carry out the activity.

Resources

- multilink cubes
- fraction discs (Activity Handbook 4 P13)

Mathematical Communication Support

Verbalise every word problem in this lesson and relate it to real life. Emphasise that the word 'of' when dealing with a fraction of a set represents multiplication. Fraction 'of' a set is expressing a subject in the form of a numerator and a denominator.

LEARNING OBJECTIVE

1. Add two fractions with answer greater than one.

ADDING FRACTIONS

LESSON
6

IN FOCUS

Farhan had $\frac{3}{5}$ of a pie.
Weiming had $\frac{7}{10}$ of a similar pie.
How many pies did they have altogether?

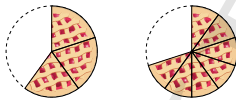

LET'S LEARN

1. To add the two fractions, we need to find the equivalent fractions with the same denominator.

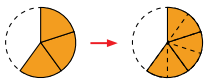

$$\frac{3}{5} = \frac{6}{10}$$

$$\frac{7}{10}$$

$$\begin{aligned} \frac{3}{5} + \frac{7}{10} &= \frac{6}{10} + \frac{7}{10} \\ &= \frac{13}{10} \\ &= 1\frac{3}{10} \end{aligned}$$

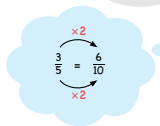

Farhan and Weiming had $1\frac{3}{10}$ pies altogether.

IN FOCUS

Pose the question to the class. Ask:

- Which operation should be used to find the answer?
- Do the fractions have the same denominator?
- How do we add the two fractions?

LET'S LEARN

Write the fraction statement on the board. Review with pupils that they must change two fractions with different denominators into like fractions with the same denominator before adding them.

For example 1, $\frac{3}{5}$ and $\frac{7}{10}$ are related fractions. So we can multiply both numerator and denominator by 2 to change $\frac{3}{5}$ to its equivalent fraction ($\frac{6}{10}$).

2. Add $\frac{2}{3}$ and $\frac{3}{4}$.

Express the answer as a mixed number in its simplest form.

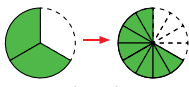

$$\frac{2}{3} = \frac{8}{12}$$

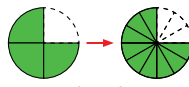

$$\frac{3}{4} = \frac{9}{12}$$

$$\begin{aligned} \frac{2}{3} + \frac{3}{4} &= \frac{8}{12} + \frac{9}{12} \\ &= \frac{17}{12} \\ &= 1\frac{5}{12} \end{aligned}$$

12 is a common multiple of 3 and 4.



3. Add the fractions using .

Express each answer as a mixed number in its simplest form.

(a) $\frac{3}{4} + \frac{5}{8} = 1\frac{3}{8}$

(b) $\frac{4}{5} + \frac{3}{10} = 1\frac{1}{10}$

(c) $\frac{4}{6} + \frac{4}{9} = 1\frac{1}{9}$

(d) $\frac{3}{4} + \frac{3}{6} = 1\frac{1}{4}$

PRACTICE

Add and express each answer as a mixed number in its simplest form.

(a) $\frac{2}{3} + \frac{5}{9} = 1\frac{2}{9}$

(b) $\frac{3}{5} + \frac{7}{10} = 1\frac{3}{10}$

(c) $\frac{11}{12} + \frac{1}{4} = 1\frac{1}{6}$

(d) $\frac{3}{4} + \frac{5}{6} = 1\frac{7}{12}$

Complete Workbook 4A, Worksheet 6 • Pages 79 – 80

Let's Learn 2 is the addition of two unrelated fractions. Ask pupils how we can make the denominators the same. Revisit equivalent fractions and common multiples if necessary. Then work through the solution.

For Let's Learn 3, allow pupils to work in pairs using fraction discs. For class discussion, highlight mistakes the pupils make and explain how it should have been done.

PRACTICE

Allow pupils to work in pairs on the practice questions before going through the solution with the class.

Independent seatwork

Assign pupils to complete Worksheet 6 (Workbook 4A P79 – 80).

Answers

Worksheet 6 (Workbook 4A P79 – 80)

1. (a) $1\frac{1}{2}$
- (b) $1\frac{2}{9}$
- (c) $1\frac{5}{8}$
- (d) $1\frac{3}{8}$
- (e) $1\frac{2}{5}$
- (f) $1\frac{7}{12}$
- (g) $1\frac{3}{10}$
- (h) $1\frac{5}{12}$
- (i) $1\frac{1}{6}$

SUBTRACTING FRACTIONS

LEARNING OBJECTIVE

1. Subtract two fractions.

SUBTRACTING FRACTIONS

LESSON
7

IN  FOCUS

Priya had 3 chocolate bars.
She gave $\frac{5}{12}$ of a chocolate bar to Ann.
How much chocolate did Priya have left?

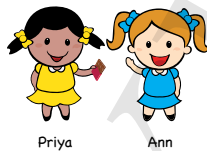

LET'S LEARN 

1.



Subtract $\frac{5}{12}$ from 1 whole.

$$1 - \frac{5}{12} = \frac{7}{12}$$

Then we add $\frac{7}{12}$ to the remaining 2 wholes.

$$2 + \frac{7}{12} = 2\frac{7}{12}$$

$$3 - \frac{5}{12} = 2\frac{7}{12}$$

Priya had $2\frac{7}{12}$ chocolate bars left.



IN  FOCUS

Discuss the problem with the class. Ask:

- What operation should we use to find the answer?
- How do we subtract a fraction from a whole number?

LET'S LEARN 

Write the fraction statement on the board and draw the pictorial model to represent 3 wholes. Divide one of the wholes into 12 equal parts and guide pupils to see that

$$1 - \frac{5}{12} = \frac{7}{12}. \text{ Next add 2 wholes to } \frac{7}{12} \text{ to give } 2\frac{7}{12}.$$

2. What is the difference between 3 and $\frac{2}{8}$?
Express your answer as a mixed number in its simplest form.

$$3 - \frac{2}{8} = 2\frac{3}{4}$$

Subtract the fractions
using $\frac{\quad}{\quad}$.



3. Subtract and express each answer in its simplest form.

(a) $1 - \frac{6}{11} - \frac{5}{11}$ (b) $4 - \frac{3}{7} - \frac{3}{7}$
(c) $3 - \frac{4}{6} - 2\frac{1}{3}$ (d) $9 - \frac{2}{8} - \frac{8}{4}$

4. Find the difference between $\frac{1}{3}$ and $\frac{1}{4}$.

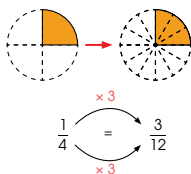
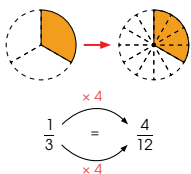

$$\frac{1}{3} - \frac{1}{4} = \frac{4}{12} - \frac{3}{12} = \frac{1}{12}$$

Work through Let's Learn 2 using fraction discs.

Remind pupils that they need to express $2\frac{6}{8}$ in its simplest form.

For Let's Learn 3, allow pair or group work. Give pupils sufficient time to work out the solution before going through. Remind pupils to express their answers in the simplest form.

For Let's Learn 4, highlight that the two fractions are unrelated fractions. Hence, they need to find their equivalent fraction that has the same denominator before subtracting.

5. Subtract and express each answer in its simplest form.

(a) $\frac{1}{2} - \frac{1}{3} - \frac{1}{6}$ (b) $\frac{4}{5} - \frac{1}{2} - \frac{3}{10}$
(c) $\frac{3}{4} - \frac{1}{3} - \frac{5}{12}$ (d) $\frac{3}{4} - \frac{1}{6} - \frac{7}{12}$

PRACTICE



1. Subtract.
Express each answer as a mixed number in its simplest form.

(a) $3 - \frac{2}{3} - \frac{1}{3}$ (b) $4 - \frac{4}{5} - \frac{3}{5}$
(c) $7 - \frac{4}{9} - \frac{5}{9}$ (d) $5 - \frac{2}{4} - \frac{1}{2}$
(e) $1 - \frac{6}{10} - \frac{2}{5}$ (f) $4 - \frac{6}{12} - \frac{1}{2}$

2. Subtract and express each answer in its simplest form.

(a) $\frac{1}{2} - \frac{2}{5} - \frac{1}{10}$ (b) $\frac{2}{3} - \frac{1}{7} - \frac{11}{21}$
(c) $\frac{4}{5} - \frac{1}{4} - \frac{11}{20}$ (d) $\frac{5}{6} - \frac{3}{4} - \frac{1}{12}$

Complete Workbook 4A, Worksheet 7 • Pages 81 – 82

Give pupils sufficient time to work on the sums in Let's Learn 5 before going through.

PRACTICE



Allow pupils to work in pairs on the practice questions. Invite pupils to show their working on the board. Work through the solution with the class and highlight common mistakes.

Independent seatwork

Assign pupils to complete Worksheet 7 (Workbook 4A P81 – 82).

1. (a) $\frac{5}{7}$

(b) $1\frac{1}{3}$

(c) $2\frac{3}{10}$

(d) $1\frac{3}{5}$

(e) $3\frac{1}{3}$

(f) $7\frac{3}{4}$

2. (a) $\frac{3}{10}$

(b) $\frac{1}{12}$

(c) $\frac{3}{14}$

(d) $\frac{7}{12}$

OXFORD
UNIVERSITY PRESS

**Specific Learning Focus**

- Add two fractions with answer greater than one.
- Subtract two fractions.

Suggested Duration

Lesson 6: 2 periods

Lesson 7: 2 periods

Prior Learning

Pupils should be well-versed with adding and subtracting like and unlike fractions. In this lesson, this concept is applied to solve real-life word problems.

Pre-emptive Pitfalls

Pupils might find lessons 6 and 7 quite challenging. Use the C-P-A approach to solve the questions by first introducing the problem with concrete materials like fraction discs. Get pupils to visualise pictorially and then move on to the abstract by forming a mathematical equation and carrying out the operation.

Introduction

Explain to the pupils that they should first identify the important information provided in the question and draw a model. Decide which operation to use (addition or subtraction). The following steps should be taken when adding or subtracting fractions:

- To add or subtract two related fractions, first change one or both fractions to its/their equivalent fraction(s).
- Identify the common multiple of both denominators and find the factor to make both fractions to like fractions by multiplying by the factor.
- To add the two like fractions, add the numerators and remember that the denominator remains the same.
- Convert your answer to a mixed numbers by breaking the improper fraction into whole(s) and proper fraction

(e.g. $\frac{17}{12} = \frac{12}{12} + \frac{5}{12} = 1\frac{5}{12}$).

Problem Solving

Pictorial representation of each sum should be done on the board (bar model or fraction discs) (Textbook 4 P91, 94). Remind pupils that when adding or subtracting fractions, unrelated fractions must be converted to like fractions. Emphasise the following:

- In addition, add the numerators;
- In subtraction, subtract the numerators, provided the denominators are the same (equivalent fractions).

Activities

Group work or pair work will enhance pupils' understanding of the concepts. Bring chocolates and pies to class (Textbook 4 P90, 92) and distribute the fractional part of food items and teach through experiential method.

Resources

- fraction discs
- food items

Mathematical Communication Support

When adding or subtracting fractions, ask questions such as the following:

- What fraction can 1 whole be written as?
- What is the lowest common multiple of the two denominators?
- What is the common factor that when both the numerator and denominator are multiplied by, will convert the two fractions into like fractions?
- Should we add/subtract the denominators too?
- To reduce the fraction to its simplest form, should we divide or multiply the common factor of the numerator and denominator?

LESSON

8

SOLVING WORD PROBLEMS

LEARNING OBJECTIVE

1. Solve up to 2-step word problems involving addition and subtraction of fractions.

SOLVING WORD PROBLEMS

LESSON
8

IN
FOCUS

Meiling had $\frac{9}{10}$ m of tape at first.

After using some tape to wrap presents, she had $\frac{1}{5}$ m of tape left.

How many metres of tape did she use to wrap the presents?

Leave your answer in its simplest form.

LET'S LEARN

1. **Step 1** Understand the problem.
Look for information to help you understand the problem.

How many metres of tape did Meiling have at first?
How many metres of tape did she use?
What do we need to find?

95
CHAPTER 3
OXFORD
UNIVERSITY PRESS

IN FOCUS

Discuss the problem with the class. Ask pupils what information they can gather from the question.

LET'S LEARN

For Let's Learn 1, model the stages of problem solving which they learnt in Chapter 2.

Step 1: Understand the problem.

Allow silent reading to understand the problem. Highlight key elements and use the questions in Tom's speech bubble as a guide to find what they need to know first.

Textbook 4 P95

Step 2 Think of a plan and carry it out.

Total length of tape at first $\frac{9}{10}$ m

Length of tape left $\frac{1}{5}$ m

Length of tape used ?

$$\frac{9}{10} - \frac{1}{5} = \frac{9}{10} - \frac{2}{10}$$

$$= \frac{7}{10}$$

Meiling used $\frac{7}{10}$ m of tape to wrap the presents.

Step 3 Check your answer.

Does the sum of $\frac{1}{5}$ and $\frac{7}{10}$ give $\frac{9}{10}$?

2. Weiming had $\frac{5}{6}$ of a pie.

Farhan had $\frac{2}{3}$ of a similar pie.

How many pies did they have altogether?

$$\frac{5}{6} + \frac{2}{3} = 1\frac{1}{2}$$

They had $1\frac{1}{2}$ pies altogether.

OXFORD UNIVERSITY PRESS

FRACTIONS

96

Textbook 4 P96

Step 2: Think of a plan and carry it out.

Ask pupils what is the best way to present the key elements. Draw the model and label the known and unknown elements. Get pupils to examine the model and ask:

- Do we add or subtract to find the answer?

The write down the fraction equation and work though the solution with the class.

Step 3: Check you answer.

Study the answer and see if the answer is reasonable.

Reinforce the stages of problem solving using Let's Learn 2.

3. Tom drank $\frac{4}{5}$ ℓ of milk.

Nora drank $\frac{1}{2}$ ℓ less milk than Tom.

(a) How many litres of milk did Nora drink?

(b) What was the total amount of milk Nora and Tom drank?

(a)

$$\frac{4}{5} - \frac{1}{2} = \frac{8}{10} - \frac{5}{10}$$

$$= \frac{3}{10}$$

Nora drank $\frac{3}{10}$ ℓ of milk.

(b)

$$\frac{3}{10} + \frac{4}{5} = \frac{3}{10} + \frac{8}{10}$$

$$= \frac{11}{10}$$

$$= 1\frac{1}{10}$$

We add to find the total volume of milk drank.

Nora and Tom drank $1\frac{1}{10}$ ℓ of milk altogether.

97

CHAPTER 3

OXFORD UNIVERSITY PRESS

Textbook 4 P97

Reinforce the stages of problem solving using

Let's Learn 3. For step 2, ask pupils what model they should draw first and how they can use this to find the next step.

4. Ahmad had a cake.
He gave $\frac{3}{8}$ of the cake away.
He then received $\frac{2}{3}$ of a similar cake from his mother.
How many cakes did Ahmad have in the end?

$$1 - \frac{3}{8} = \frac{5}{8}$$

Ahmad had $\frac{5}{8}$ cakes left.

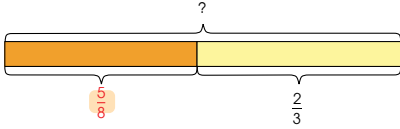

$$\frac{5}{8} + \frac{2}{3} = 1\frac{7}{24}$$

Ahmad had $1\frac{7}{24}$ cakes in the end.

What does receive mean?
Do we add or subtract to find
the number of cakes?



Textbook 4 P98

Allow pupils to work in pairs for Let's Learn 4. Teacher to follow up by modeling the stages of problem solving process.

Work in groups of 4.

- 1 Pick two $\frac{1}{2}$ and one 2 .

Write a word problem using the two fractions and the whole number.

Example

Tom had 2 ℓ of juice. He drank $\frac{1}{2}$ ℓ of juice.
He then gave away $\frac{3}{10}$ ℓ of juice.
How many litres of juice had he left?

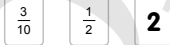

What you need:



- 2 Create another two word problems.
Pick another two $\frac{1}{2}$ and one 2 for each problem.
3 Exchange your word problems with another group.
Get them to solve each problem.

PRACTICE

Solve.

1. Kate has to walk 2 km from her home to her school.
She walks $\frac{3}{8}$ km less from her home to the library.
What is the distance between Kate's home and the library? $2 \text{ km} - \frac{3}{8} \text{ km} = 1\frac{5}{8} \text{ km}$
2. Weiming drank $\frac{7}{10}$ ℓ of water.
Ann drank $\frac{1}{4}$ ℓ less water than Weiming.
How many litres of water did Ann drink? $\frac{7}{10} \text{ ℓ} - \frac{1}{4} \text{ ℓ} = \frac{9}{20} \text{ ℓ}$

Textbook 4 P99

ACTIVITY TIME



The activity allows the pupils to work in groups to create 2-step word problems involving addition and subtraction of fractions for other groups to solve.

PRACTICE



Allow pupils to work in pairs on the practice questions. Invite pupils to show their working on the board. Work through the solution by modeling the stages of problem solving process.

Independent seatwork

Assign pupils to complete Worksheet 8 (Workbook 4A P83 – 86).

3. Mr Tan had 2 kg of sugar.
He used $\frac{1}{4}$ kg of sugar to make dessert and $\frac{3}{5}$ kg of sugar to bake some cakes.
(a) What was the total mass of sugar used? $(a) \frac{1}{4} \text{ kg} + \frac{3}{5} \text{ kg} = \frac{17}{20} \text{ kg}$
(b) How much sugar did he have left? $(b) 2 \text{ kg} - \frac{17}{20} \text{ kg} = 1\frac{3}{20} \text{ kg}$
4. Junhao had 1 m of wire.
He used $\frac{2}{5}$ m of wire to make a keychain. $1 \text{ m} - \frac{2}{5} \text{ m} = \frac{3}{5} \text{ m}$
He then bought another $\frac{3}{4}$ m of wire. $\frac{3}{5} \text{ m} + \frac{3}{4} \text{ m} = 1\frac{7}{20} \text{ m}$
What was the total length of wire he had in the end?

Complete Workbook 4A, Worksheet 8 • Pages 83 – 86



MIND WORKOUT

Nora has some red and white cups.

$\frac{4}{9}$ of the cups are red.

There are 10 more white cups than red cups.

How many cups does she have altogether?

$$\frac{5}{9} - \frac{4}{9} = \frac{1}{9}$$

$$1 \text{ unit} = 10$$

$$9 \text{ units} = 90$$

OXFORD
UNIVERSITY PRESS

FRACTIONS 100

Textbook 4 P100

Answers Worksheet 8 (Workbook 4A P83 – 86)

1. $\frac{3}{4} + \frac{7}{12} = 1\frac{1}{3}$

They had $1\frac{1}{3}$ cakes altogether.

2. $\frac{3}{5} \text{ m} + \frac{3}{4} = 1\frac{7}{20} \text{ m}$

The length of Xinyi's ribbon is $1\frac{7}{20}$ m.

3. $2 \ell - \frac{7}{10} \ell = 1\frac{3}{10} \ell$

Mrs Chan had $1\frac{3}{10} \ell$ of lemonade left.

4. $\frac{3}{5} \text{ kg} - \frac{1}{2} \text{ kg} = \frac{1}{10} \text{ kg}$

He used $\frac{1}{10}$ kg of flour to bake the cookies.

5. (a) $\frac{3}{8} \text{ kg} + \frac{1}{4} \text{ kg} = \frac{5}{8} \text{ kg}$

She used $\frac{5}{8}$ kg of flour on both days.

(b) $5 \text{ kg} - \frac{5}{8} \text{ kg} = 4\frac{3}{8} \text{ kg}$

She had $4\frac{3}{8}$ kg of flour left.

6. (a) $\frac{5}{6} \text{ hr} + \frac{1}{5} \text{ hr} = \frac{19}{30} \text{ hr}$

Raju took $\frac{19}{30}$ hr to complete his English homework.

(b) $\frac{19}{30} \text{ hr} + \frac{5}{6} \text{ hr} = 1\frac{7}{15} \text{ hr}$

Raju spent a total of $1\frac{7}{15}$ hr on his homework.

7. $\frac{2}{5} \text{ m} + \frac{1}{2} \text{ m} = \frac{9}{10} \text{ m}$

$$3 \text{ m} - \frac{9}{10} \text{ m} = 2\frac{1}{10} \text{ m}$$

Mr Lim had $2\frac{1}{10}$ m of rope left.

PROBLEM SOLVING, MATHS JOURNAL AND PUPIL REVIEW

3. Mr Tan had 2 kg of sugar.

He used $\frac{1}{4}$ kg of sugar to make dessert and $\frac{3}{5}$ kg of sugar to bake some cakes.

- (a) What was the total mass of sugar used? (a) $\frac{1}{4}$ kg + $\frac{3}{5}$ kg = $\frac{17}{20}$ kg
(b) How much sugar did he have left? (b) 2 kg - $\frac{17}{20}$ kg = $1\frac{3}{20}$ kg

4. Junhao had 1 m of wire.

He used $\frac{2}{5}$ m of wire to make a keychain. 1 m - $\frac{2}{5}$ m = $\frac{3}{5}$ m

He then bought another $\frac{3}{4}$ m of wire. $\frac{3}{5}$ m + $\frac{3}{4}$ m = $1\frac{7}{20}$ m

What was the total length of wire he had in the end?

Complete Workbook 4A, Worksheet 6 • Pages 83 - 86



MIND WORKOUT

Nora has some red and white cups.

$\frac{4}{9}$ of the cups are red.

There are 10 more white cups than red cups.

How many cups does she have altogether?

$$\frac{5}{9} - \frac{4}{9} = \frac{1}{9}$$

$$1 \text{ unit} = 10$$

$$9 \text{ units} = 90$$



MIND WORKOUT

The Mind Workout challenges pupils to use comparison model to solve the problem.

7. Mr Lim had 3 m of rope.
He used $\frac{2}{5}$ m of rope to tie Parcel A and $\frac{1}{2}$ m of rope to tie Parcel B.
How many metres of rope did Mr Lim have left?

$$\frac{2}{5}m + \frac{1}{2}m = \frac{9}{10}m$$

$$3m - \frac{9}{10}m = 2\frac{1}{10}m$$

Answer: $2\frac{1}{10}m$



Mind Workout

Date: _____

Nora drew some circles and shaded 10 circles as shown below.
How many more circles must she draw so that $\frac{1}{4}$ of the circles shown are shaded?

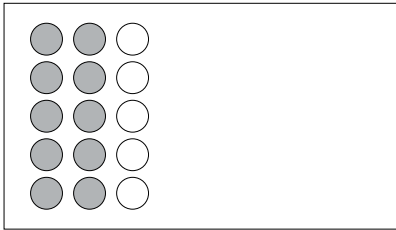

She must draw **25** more circles.

86 Chapter 3

OXFORD
UNIVERSITY PRESS

Workbook 4A P86



Mind Workout

This task requires pupils to associate the 10 shaded circles as a group and then apply fraction of a set concept to derive the total number of unshaded circles.

MATHS JOURNAL

Ahmad has 3 blue pens and 4 black pens.
He says that $\frac{1}{3}$ of his pens are blue.
Is he correct?
Explain your answer.



I know how to...

- write mixed numbers.
- write improper fractions.
- convert mixed numbers to improper fractions.
- convert improper fractions to mixed numbers.
- compare and order fractions.
- find the fraction of a set.
- add fractions.
- subtract fractions.
- solve word problems involving fractions.

SELF-CHECK



101 CHAPTER 3

OXFORD
UNIVERSITY PRESS

Textbook 4 P101

MATHS JOURNAL

The objective is to challenge pupils to uncover the error in the fraction of a set. Encourage pupils to use the appropriate terms to explain their answers.

Before doing the self-check, review important concepts.

The self-check can be done after pupils have completed **Review 3** (Workbook 4A P87 – 92) as a consolidation of understanding for the chapter.

SELF-CHECK



1. (a) $1\frac{3}{4}$
 (b) $2\frac{2}{3}$
 (c) $1\frac{1}{2}$

2. (a) $\frac{7}{4}$
 (b) $\frac{4}{3}$
 (c) $\frac{13}{5}$
 (d) $\frac{11}{4}$

3. (a) $2\frac{2}{3}$
 (b) $4\frac{1}{3}$
 (c) $1\frac{3}{5}$
 (d) $2\frac{1}{2}$

4. (a) $\frac{7}{4}$
 (b) $\frac{7}{3}$
 (c) $\frac{12}{5}$
 (d) $\frac{19}{6}$

5. $45 \div 5 = 9$
 $9 \times 3 = 27$
 27 pupils do not wear glasses.

6. $96 \div 6 = 16$
 $16 \times 5 = 80$
 There are 80 ripe mangoes.

7. $\$56 \div 2 = \28
 $\$28 + \$15 = \$43$
 He spent \$43.

8. (a) $1\frac{1}{12}$
 (b) $1\frac{1}{2}$
 (c) $1\frac{2}{3}$
 (d) $1\frac{4}{9}$

9. (a) $1\frac{1}{6}$
 (b) $4\frac{2}{3}$
 (c) $\frac{1}{12}$
 (d) $\frac{1}{6}$

10. (a) $\frac{9}{10} - \frac{1}{4} = \frac{13}{20}$

The height of Plant B is $\frac{13}{20}$ m.

- (b) $\frac{9}{10} + \frac{13}{20} = 1\frac{11}{20}$

The total height of both plants is $1\frac{11}{20}$ m.

11. $1 - \frac{1}{4} = \frac{3}{4}$

$$\frac{3}{4} - \frac{2}{3} = \frac{1}{12}$$

He is left with $\frac{1}{12}$ of a pizza.

- *12. $\frac{1}{2}$ mass of sand $\rightarrow 1 \text{ kg} - \frac{5}{8} \text{ kg} = \frac{3}{8} \text{ kg}$

$$\text{container} \rightarrow \frac{5}{8} \text{ kg} - \frac{3}{8} \text{ kg} = \frac{2}{8} \text{ kg} = \frac{1}{4} \text{ kg}$$

The mass of the empty container is $\frac{1}{4}$ kg.

1. (a) 45 811
 (b) 80 028
 (c) 39 405

2. (a) Twenty-three thousand, seven hundred and forty-five
 (b) Fifty-four thousand, six hundred and eight
 (c) Eighty-nine thousand and five

3. (a) 40 000
 (b) 8000
 (c) hundreds
 (d) 0
 (e) ones

4. (a) 64 083, 64 388, 64 403, 64 838
 (b) 35 625, 35 265, 35 256, 29 876

5. (a) 65 400, 65 410
 (b) 71 903, 71 603
 (c) 40 529, 39 529

6. (a)

$67 \approx 70$	$306 \approx 310$
$2595 \approx 2600$	$47\,853 \approx 47\,850$

(b)

$657 \approx 700$	$4909 \approx 4900$
$80\,051 \approx 80\,100$	$99\,999 \approx 100\,000$

(c)

$4590 \approx 5000$	$5575 \approx 6000$
$20\,362 \approx 20\,000$	$90\,815 \approx 91\,000$

7. (a) 1, 2, 3, 6, 9, 18
 (b) 1, 2, 4, 8, 16

8. (a) 7, 14, 21
 (b) 12, 24

9. (a) 16 457

$$\begin{array}{r} ^2^3^5^1 \\ 16457 \\ \times 7 \\ \hline 116457 \end{array}$$

- (c) 11 880

$$\begin{array}{r} ^3^6^4^8^5 \\ 11880 \\ \times 8 \\ \hline 95040 \end{array}$$

- (e) 3672

$$\begin{array}{r} ^6^8 \\ 3672 \\ \times 54 \\ \hline 14688 \\ 18036 \\ \hline 198000 \end{array}$$

- (g) 20 664

$$\begin{array}{r} ^2^4^6 \\ 20664 \\ \times 84 \\ \hline 82656 \\ 165312 \\ \hline 1740768 \end{array}$$

10. (a) 214

$$\begin{array}{r} ^2^1^4 \\ 6 \overline{) 1284} \\ \underline{-12} \\ 08 \\ \underline{-6} \\ 24 \\ \underline{-24} \\ 0 \end{array}$$

- (c) 542

$$\begin{array}{r} ^5^4^2 \\ 8 \overline{) 4336} \\ \underline{-40} \\ 33 \\ \underline{-32} \\ 16 \\ \underline{-16} \\ 0 \end{array}$$

- (b) 20 772

$$\begin{array}{r} ^3^3^4^1^6^2 \\ 20772 \\ \times 6 \\ \hline 124632 \end{array}$$

- (d) 28 476

$$\begin{array}{r} ^1^3^5^1^3^6^4 \\ 28476 \\ \times 9 \\ \hline 256284 \end{array}$$

- (f) 5481

$$\begin{array}{r} ^8^7 \\ 5481 \\ \times 63 \\ \hline 16443 \\ 32886 \\ \hline 344811 \end{array}$$

- (h) 13 938

$$\begin{array}{r} ^6^0^6 \\ 13938 \\ \times 23 \\ \hline 41814 \\ 27876 \\ \hline 320574 \end{array}$$

- (b) 338 r 3

$$\begin{array}{r} ^3^3^8^r^3 \\ 7 \overline{) 2369} \\ \underline{-21} \\ 26 \\ \underline{-21} \\ 59 \\ \underline{-56} \\ 3 \end{array}$$

- (d) 667

$$\begin{array}{r} ^6^6^7 \\ 9 \overline{) 6003} \\ \underline{-54} \\ 60 \\ \underline{-54} \\ 63 \\ \underline{-63} \\ 0 \end{array}$$

1. Sunday $\rightarrow 4380 + 1290 = 5670$
 Monday $\rightarrow 4380 - 800 = 3580$
 $3580 + 5670 = 9250$

9250 people visited Sentosa on Sunday and Monday in total.

2. $360 \div 4 = 90$
 $90 \times 3 = 270$
 $270 \times \$5 = \1350

\$1350 was collected from the sale of child tickets.

3. $\$2016 \div \$8 = 252$
 $252 \times 12 = 3024$
 $3024 + 250 = 3274$

She baked 3274 bags of cookies at first.

4. (a) $2\frac{3}{4}$
 (b) $3\frac{1}{6}$
 (c) $4\frac{2}{7}$
 (d) $3\frac{1}{4}$

5. (a) $\frac{13}{4}$
 (b) $\frac{32}{7}$
 (c) $\frac{23}{8}$
 (d) $\frac{41}{11}$

6. (a) $3\frac{3}{4}$
 (b) $2\frac{4}{5}$
 (c) $\frac{14}{3}$
 (d) $\frac{17}{4}$
 (e) $\frac{11}{3}$
 (f) $\frac{15}{4}$

7. $\$81 \div 9 = \9
 $\$9 \times 2 = \18

The storybook cost \$18.

8. (a) $1\frac{1}{8}$
 (b) $1\frac{1}{3}$
 (c) $1\frac{7}{12}$
 (d) $1\frac{3}{10}$
 (e) $1\frac{1}{3}$
 (f) $3\frac{2}{7}$
 (g) $3\frac{3}{8}$
 (h) $4\frac{3}{4}$
 (i) $\frac{1}{3}$
 (j) $\frac{3}{10}$

9. (a) $\frac{1}{2} \text{ kg} + \frac{2}{5} \text{ kg} = \frac{9}{10} \text{ kg}$

She used $\frac{9}{10}$ kg of sugar altogether.

- (b) $2 \text{ kg} - \frac{9}{10} \text{ kg} = 1\frac{1}{10} \text{ kg}$

She had $1\frac{1}{10}$ kg of sugar left.

10. $\frac{2}{3} \text{ hr} - \frac{1}{4} \text{ hr} = \frac{5}{12} \text{ hr}$

$$\frac{5}{12} \text{ hr} - \frac{2}{3} \text{ hr} = 1\frac{1}{12} \text{ hr}$$

He spent $1\frac{1}{12}$ hr doing his homework in total.

SYMMETRY

CHAPTER

4

Symmetry CHAPTER 4



Can you name some examples of symmetric figures around you?

COMPLETING SYMMETRIC FIGURES LESSON 1

RECAP
These shapes have a line of symmetry.



vertical line of symmetry horizontal line of symmetry diagonal line of symmetry

OXFORD UNIVERSITY PRESS SYMMETRY 102

Textbook 4 P102

Related Resources

NSPM Textbook 4 (P102 – 106)
NSPM Workbook 4A (P105 – 108)

Materials

Origami paper, scissors, square grid paper, ruler, pencil, symmetrical figure cards, markers

Lesson

Lesson 1 Completing Symmetric Figures
Problem Solving, Maths Journal and Pupil Review

INTRODUCTION

Symmetry was introduced in Grade Two. The key skill required is pupils' ability to visualise the folding of a given figure to form a 'reflected' image. The figure may come in the form of shapes, letters, figures and patterns drawn on the square grid paper. To help pupils visualise, they will have the opportunity to cut and fold figures.

LESSON

1

COMPLETING SYMMETRIC FIGURES

LEARNING OBJECTIVE

1. Complete a symmetric figure with respect to a given line of symmetry on square grid.

RECAP

Recapitulate with pupils that a line of symmetry of a shape is a line that cuts the shape into two equal halves.

Symmetry

CHAPTER 4

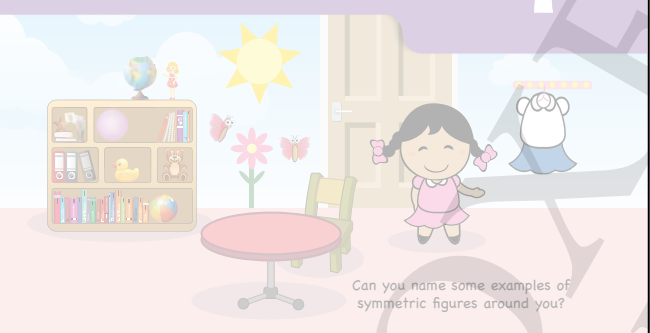

Can you name some examples of symmetric figures around you?

COMPLETING SYMMETRIC FIGURES

LESSON 1

RECAP

These shapes have a line of symmetry.



vertical line of symmetry



horizontal line of symmetry



diagonal line of symmetry

OXFORD UNIVERSITY PRESS

SYMMETRY 102

Textbook 4 P102

How do we complete the symmetric figure?

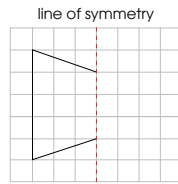

LET'S LEARN

1.

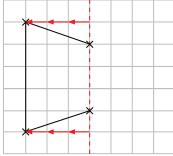

Step 1 Indicate all points of the shape given. Count the number of squares between each point and the line of symmetry.

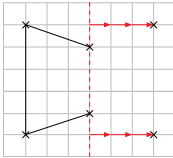

Step 2 Count the same number of squares along the same horizontal line on the opposite side. Mark out these points.

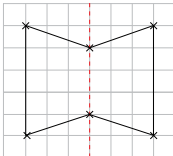

Step 3 Join the points you have marked out.

Use the figure in In Focus (P114) to stimulate discussion on how we can complete the symmetric figure. Get pupils to identify the line of symmetry and the points of the figure.

LET'S LEARN

Guide pupils to count the number of squares from the line of symmetry to the points. Next, get pupils to count the same number of squares on the opposite side of the line of symmetry. Demonstrate the steps to mark and connect the points. Then remind pupils to check if the figure is symmetric along the given line of symmetry.

2. Trace and complete each symmetric figure on .

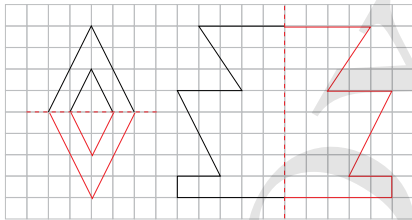

3. Copy and complete the symmetric pattern on .

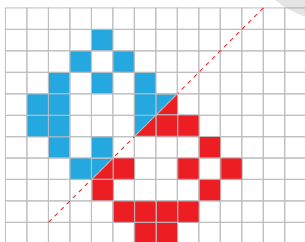

For Let's Learn 2, distribute square grid papers to pupils. After tracing the figure onto their square grid paper, guide pupils to complete the figures by first counting and marking the points. Select some pupils to present their figures.

Introduce the pattern in Let's Learn 3 to the pupils. Explain that besides drawing an outline to complete a symmetric figure, sometimes pupils are required to shade to complete symmetric pattern. Encourage pupils to tilt the book such that the line of symmetry is lying horizontally or vertically. Allow pupils to discuss which direction they prefer. Then demonstrate procedurally the steps to complete the pattern. Get pupils to participate by counting the squares.



1. Complete each of the following symmetric figures.

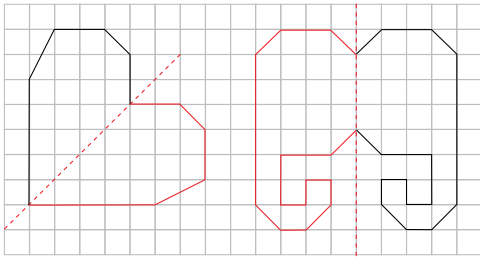

2. Complete each of the following symmetric patterns.

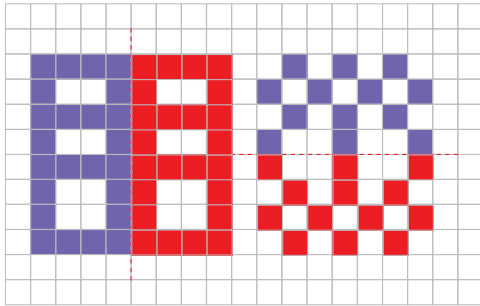

Complete Workbook 4A, Worksheet 1 • Pages 105 – 106



Give pupils sufficient time to complete the symmetric figures by copying the figures or patterns onto the square grid paper. Then work with pupils to complete each figure or pattern.

Independent seatwork

Assign pupils to complete Worksheet 1 (Workbook 4A P105 – 106).

Answers Worksheet 1 (Workbook 4A P105 – 106)

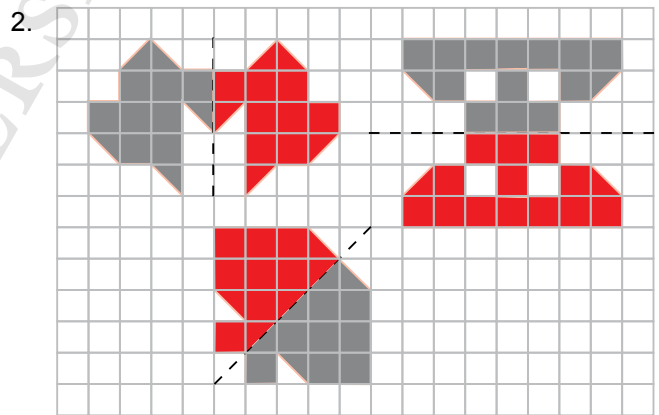
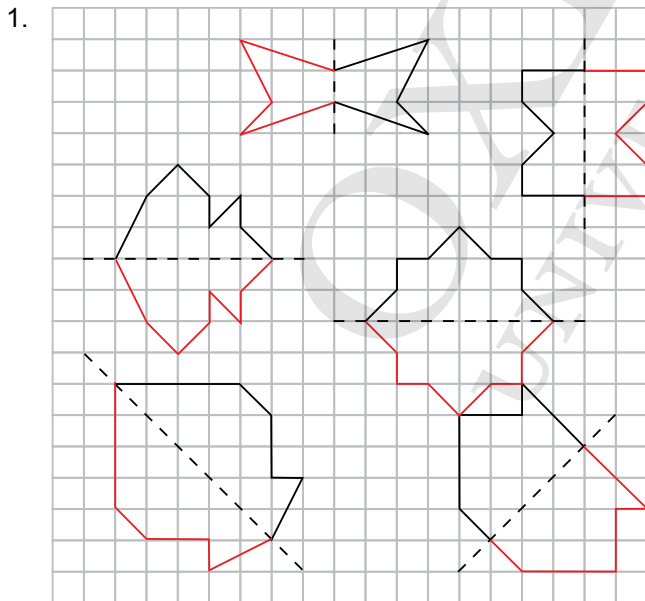

**Specific Learning Focus**

- Complete a symmetric figure with respect to a given line of symmetry on square grid.

Suggested Duration

4 periods

Prior Learning

Pupils have learnt that the line of symmetry of a shape is the line that cuts the shape into two equal halves.

Recapitulate with pupils the fraction half ($\frac{1}{2}$).

Pre-emptive Pitfalls

Pupils might find it quite challenging to complete a symmetric figure on a square grid. Pupils need ample practice in drawing. Guide pupils to count the squares and see that when the symmetric figure is folded along the line of symmetry, they overlap exactly.

Introduction

Recapitulate the concept of line of symmetry. Use the idea of mirror image to explain. Explain that there are three types of lines of symmetry: horizontal, vertical and diagonal/slant. Identify symmetric two-dimensional shapes in the classroom together with the pupils and draw them on the board. Identify the line of symmetry together with the pupils. Guide pupils to complete a symmetric figure by first identifying the points (e.g. vertices) of the figure by marking out with dots. Then, proceed to count the number of squares from the line of symmetry to the points, and then count the same number of squares from the line of symmetry to the opposite side of the line of symmetry. Get them to mark out each point with a dot. Ask them to repeat the steps for all the points marked out.

Problem Solving

For lines of symmetry that are vertical or horizontal, pupils should not have difficulty completing the symmetric figure. However, for a line of symmetry that is diagonal, the distance is not measured horizontally or vertically but diagonally across the squares. Completing symmetric figures on square grid makes it easier to identify the points of the figure to be mirrored about the line of symmetry.

Activities

Provide pupils with markers and the template to do independent seatwork.

Resources

- square grid paper (Activity Handbook 4 P24)
- ruler
- pencil
- symmetric figure cards (Activity Handbook 4 P25 – 26)
- markers

Mathematical Communication Support

Verbalise the questions in 'Practice' (Textbook 4 P104 – 105) and write on the board. Ask pupils to identify if the line of symmetry is vertical, horizontal or diagonal. Ask them to use the key terms and say them out loud. Get them to differentiate between a vertical and horizontal line of symmetry. Elicit individual responses for identifying the points on the figure to be mirrored about the line of symmetry.

PROBLEM SOLVING, MATHS JOURNAL AND PUPIL REVIEW



MIND WORKOUT

The halves of three symmetrical figures are shown.

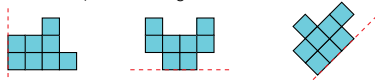

Use any two of the following pieces to complete each symmetric figure.

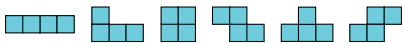

Each piece may be used for more than one figure.



MATHS JOURNAL

Cut a symmetric figure from a piece of origami paper. First fold the paper, then cut the figure.

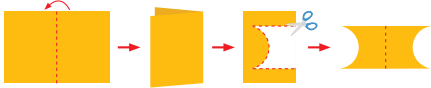

You can try different ways of folding the paper before cutting it.



Share the figures you made with the class.

I know how to...

complete a symmetric figure on a square grid.

SELF-CHECK



OXFORD
UNIVERSITY PRESS

SYMMETRY 106

Textbook 4 P106



MIND WORKOUT

Distribute square grid papers to pupils. Get pupils to trace the figures onto the square grid paper. To facilitate the activity, teacher may provide cutouts of the figures so that pupils can manipulate the figures to complete the symmetric figure.

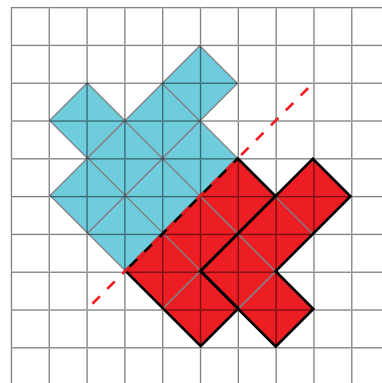
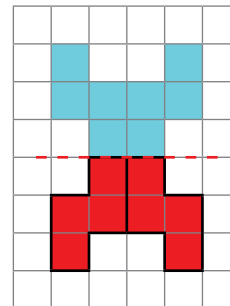
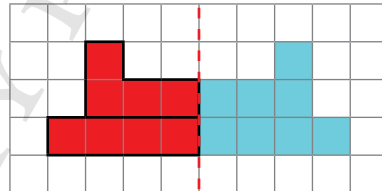

2. Shade the squares to make the patterns symmetrical.

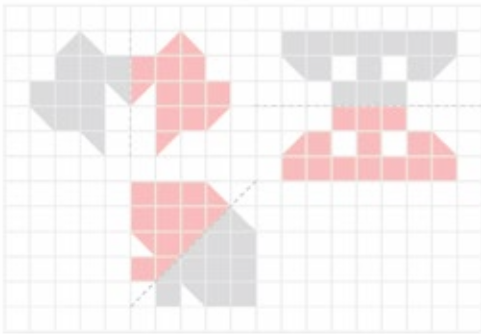

Mind Workout

Date: _____

The number 88 is a symmetric number.



Can you think of symmetric numbers with

- (a) 3 digits. **Teacher to accept**
- (b) 4 digits. **all reasonable**
- (c) 5 digits? **answers.**

What can you see about the numbers formed?

106 Chapter 4



Mind Workout

If pupils have difficulty approaching the question, ask pupils to list down the digits that have a vertical line of symmetry before forming the numbers.

Workbook 4A P106



MIND WORKOUT

The halves of three symmetrical figures are shown.

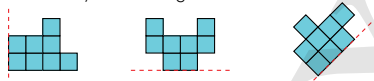

Use any two of the following pieces to complete each symmetric figure.



Each piece may be used for more than one figure.

MATHS JOURNAL

Cut a symmetric figure from a piece of origami paper. First fold the paper, then cut the figure.



You can try different ways of folding the paper before cutting it.



Share the figures you made with the class.

I know how to...

- complete a symmetric figure on a square grid.

SELF-CHECK



OXFORD
UNIVERSITY PRESS

SYMMETRY 106

Textbook 4 P106

MATHS JOURNAL

The activity allow pupils to use origami papers to cut out symmetric figures of different shapes. Highlight to pupils that the fold line is the line of symmetry.

Before the pupils do the self-check, review the important concepts and steps once more by asking for examples learnt for each objective.

This self-check can be done after pupils have completed **Review 4** (Workbook 4A P107 – 108) as consolidation of understanding for the chapter.

SELF-CHECK



1.

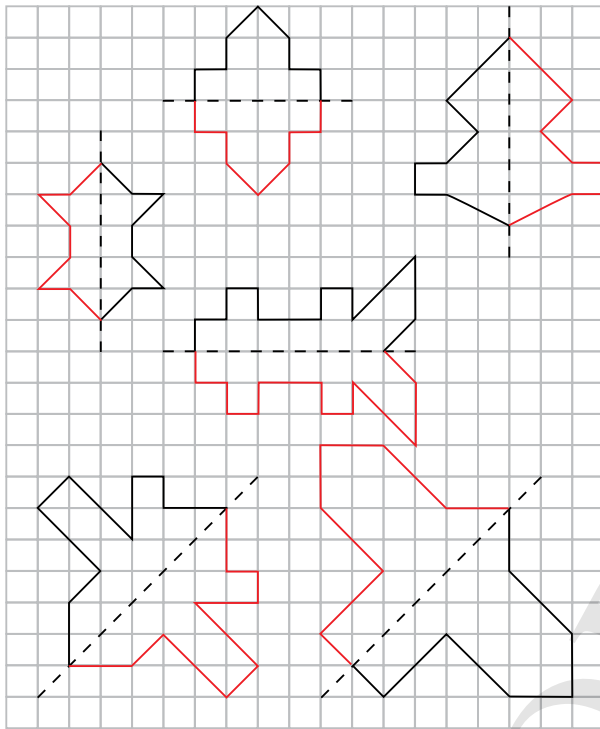

2.

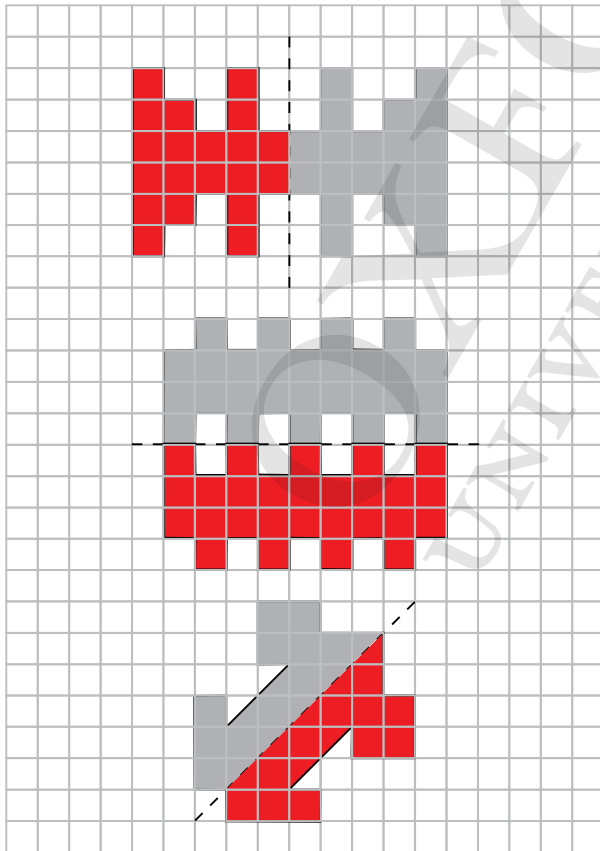

ANGLES

CHAPTER

5

Angles

CHAPTER
5

How can angles be measured?

MEASURING ANGLES

LESSON
1

IN FOCUS

How can Tom measure $\angle b$ and $\angle DEF$?

We can name angles in two ways.
 $\angle b$ and $\angle DEF$ are angles.

107 CHAPTER 5

OXFORD
UNIVERSITY PRESS

Textbook 4 P107

Related Resources

NSPM Textbook 4 (P107 – 124)
NSPM Workbook 4A (P109 – 124)

Materials

Protractor, 8-point compass, clock, ruler,
pencil

Lesson

Lesson 1 Measuring Angles
Lesson 2 Drawing Angles
Lesson 3 Turns and Right Angles
Lesson 4 8-Point Compass

Problem Solving, Maths Journal and
Pupil Review

INTRODUCTION

In Grade Three, the right angle was used as a unit of comparison. Acute angles are angles smaller than a right angle and obtuse angles are angles greater than a right angle. In Grade Four, pupils will learn to use a protractor to draw and measure angles. Pupils will learn to deduce if a given angle is smaller or bigger than a right angle.

Pupils will apply the concept of angles on turns and the 8-point compass. They will learn about clockwise and anticlockwise movements and associate $\frac{1}{4}$, $\frac{1}{2}$, $\frac{3}{4}$ and 1 complete turn to the size of the angles and the number of right angles. Next, pupils will apply their knowledge on angles, direction and turns to name and describe directions using an 8-point compass.

MEASURING ANGLES

LEARNING OBJECTIVES

1. Use notation such as $\angle ABC$ and $\angle a$ to name angles.
2. Measure angles in degrees.

Angles
CHAPTER 5

How can angles be measured?

MEASURING ANGLES

We can name angles in two ways.
 $\angle b$ and $\angle DEF$ are angles.

107 CHAPTER 5
OXFORD UNIVERSITY PRESS

Textbook 4 P107

IN FOCUS

Review with pupils the relative size of the two angles (whether it is acute or obtuse). Introduce the protractor and explain that we can know the exact size of the angles by measuring them with a protractor. Using the two angles shown, explain that angles can be named using notations such as $\angle b$ and $\angle DEF$. Explicate the difference in the two notations.

LET'S LEARN

- We can measure angles using a protractor.
We measure angles in **degrees**.
The symbol stands for degree.

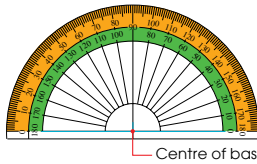

Each small marking is 1°.



The orange part is the outer scale.
The green part is the inner scale.
The blue line is the base line.

We read the scale from left to right to measure an angle using the outer scale.
We read the scale from right to left to measure an angle using the inner scale.

- $\angle PQR$ is a right angle.
We use a protractor to measure it in degrees.

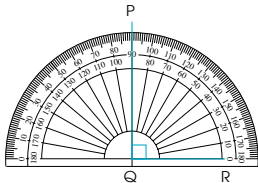

Place the base line of the protractor on line QR.
Make sure the centre of the base line is placed at Q.
Reading off the protractor, $\angle PQR$ is 90° .

Textbook 4 P108

Project the protractor on the screen. Familiarise pupils with the parts of the protractor;

- outer scale (orange)
- inner scale (green)
- base line (blue)
- centre of the base line

Introduce the degree symbol '°'. Explain that angles are measured in degrees. Like measuring length, measuring angles begins at zero too. Hence, if the outer scale is used, we read from left to right and vice versa if the inner scale is used.

Explain to pupils that a right angle is equal to 90° .

To show that $\angle PQR$ is a right angle in Let's Learn 2, we can use a protractor to measure it.

Steps:

- Place the base line (blue) of the protractor exactly along the line QR.
- Ensure that the centre of the base line is exactly at Q.
- Read off the protractor.

$\angle PQR$ is 90° , it is a right angle.

- What is the size of $\angle b$?

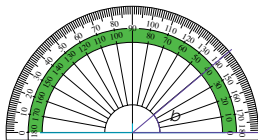

Is $\angle b$ greater or smaller than 90° ?



Place the base line of the protractor on a line of the angle.
Make sure the point where the lines meet is at the centre of the base line.
Reading off the inner scale, $\angle b$ is 40° .

When the angle is acute, read off the number that is smaller than 90° .



- What is the size of $\angle DEF$?

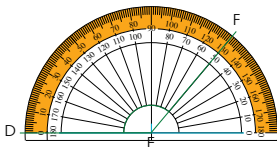

Is $\angle DEF$ greater or smaller than 90° ?



Place the base line of the protractor on line DE.
Make sure point E lies at the centre of the base line.
Reading off the outer scale, $\angle DEF$ is 130° .

When the angle is obtuse, read off the number that is greater than 90° .



Textbook 4 P109

For Let's Learn 3, ask the pupils:

- Is $\angle b$ an acute or obtuse angle?
- Do you think it is greater than or smaller than 90° ?

Follow the steps introduced in Let's Learn 2. Remind pupils that $\angle b$ is an acute angle so its reading should be smaller than 90° . Hence we read off the inner scale (green).

Before reading off the protractor, estimate whether it is an acute or obtuse angle.

Since it is an obtuse angle, it is greater than 90° . Hence, we read off the number greater than 90° .

Work in pairs.

- 1 Estimate the size of each marked angle.
- 2 Use a protractor to measure the size of each marked angle.

What you need:

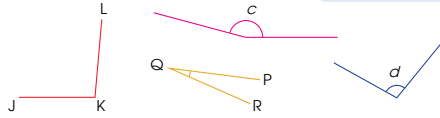

Pupils will work in pairs. The activity provides pupils with more practice on estimating and measuring angles using the protractor.

PRACTICE 

1. Find the size of each angle.

(a)

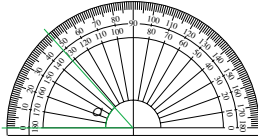

$\angle O = 48^\circ$

(b)

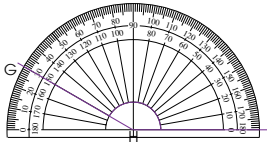

$\angle GHI = 150^\circ$

OXFORD UNIVERSITY PRESS

ANGLES 110

PRACTICE 

Allow pupils to work on the solution first before going through the practice questions.

Textbook 4 P110

2. Measure each marked angle.

(a)

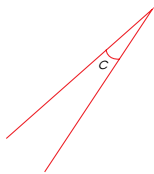

$\angle C = 15^\circ$

(b)

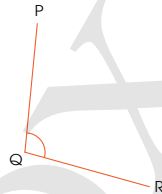

$\angle PQR = 100^\circ$

 Complete Workbook 4A, Worksheet 1 • Pages 109–110

Independent seatwork

Assign pupils to complete Worksheet 1 (Workbook 4A P109 – 110).

111

CHAPTER 5

OXFORD UNIVERSITY PRESS

Textbook 4 P111

1. (a) 105
(b) 42
(c) 160
(d) 78

2. (a) 126
(125° and 127° can be accepted)
(b) 35
(34° and 36° can be accepted)
(c) 65
(64° and 66° can be accepted)
(d) 86
(85° and 87° can be accepted)
(e) 142
(141° and 143° can be accepted)
(f) 174
(173° and 175° can be accepted)

OXFORD
UNIVERSITY PRESS

LEARNING OBJECTIVE

1. Draw angles using a protractor.

DRAWING ANGLES

IN FOCUS

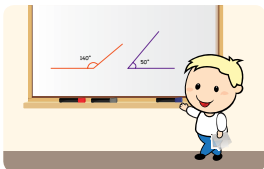

How can Tom draw the angles?

LET'S LEARN

1. Draw an angle measuring 140° .
Label this angle as $\angle ABC$.

Step 1 Draw a straight line and put a small marking at the centre. Place the base line of the protractor on the line that you have drawn.

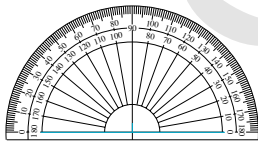
OXFORD
UNIVERSITY PRESS

ANGLES 112

LESSON
2

IN FOCUS

Using the In Focus, explain that besides using the protractor to measure angles, it can also be used to draw angles.

LET'S LEARN

Before drawing the angle ask pupils if $\angle ABC$ is an acute or obtuse angle. Then get pupils to estimate and sketch how $\angle ABC$ should look like. Next, guide pupils through the four steps in Let's Learn 1.

Remind pupils to mark and label $\angle ABC$.

- Step 2** Find the 140° mark.
Mark with a dot.

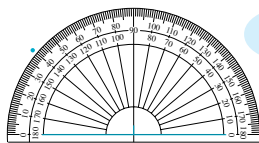

We can draw the angle from the left or the right side of the protractor.



- Step 3** Remove the protractor.
Connect the dot to the centre of your line.



- Step 4** Label the angle.

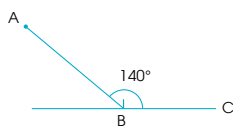

113 CHAPTER 5

OXFORD
UNIVERSITY PRESS

Textbook 4 P113

- 2.** Draw an angle measuring 50° .
Label the angle $\angle q$.

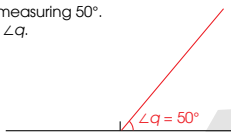

PRACTICE

- 1.** Draw and label the angles.
(a) $\angle FGH = 70^\circ$

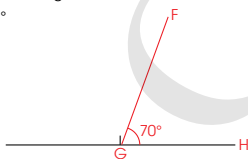

- (b) $\angle XYZ = 124^\circ$

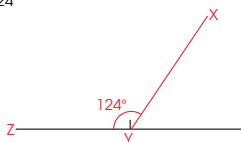

- 2.** Draw the following angles.

- (a) $\angle m = 85^\circ$ (b) $\angle n = 175^\circ$
(c) $\angle JKL = 23^\circ$ (d) $\angle MNO = 159^\circ$

Complete Workbook 4A, Worksheet 2 • Pages 111 – 114

OXFORD
UNIVERSITY PRESS

ANGLES

114

Textbook 4 P114

For Let's Learn 2, guide pupils step-by-step through the four steps to drawing an angle learnt in Let's Learn 1.

PRACTICE

For practice question 1, guide the class through the four steps to drawing an angle. For practice question 2, give pupils sufficient time to draw the angles. Remind pupils to estimate how each angle should look before drawing each one. Accept angles that are $\pm 1^\circ$.

Independent seatwork

Assign pupils to complete Worksheet 2 (Workbook 4A P111 – 114). Accept angles that are $\pm 1^\circ$.

1. (a)

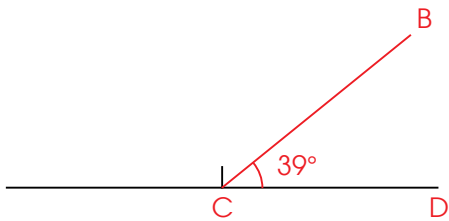

(b)

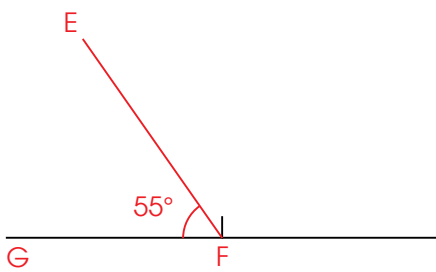

(c)

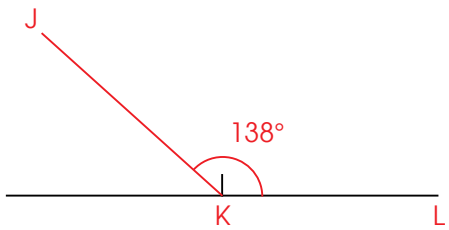

(d)

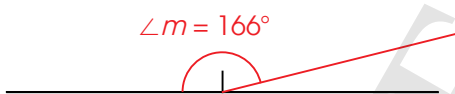

(e)

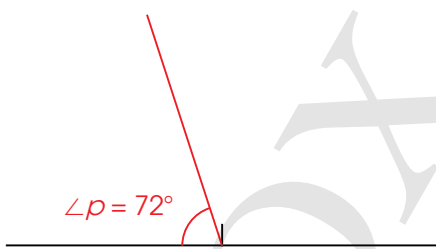

(f)

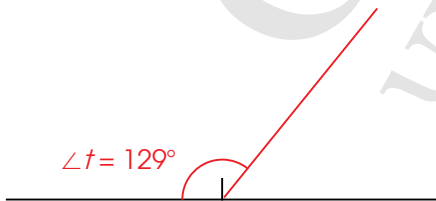

2. (a)

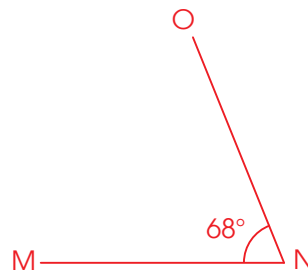

(b)

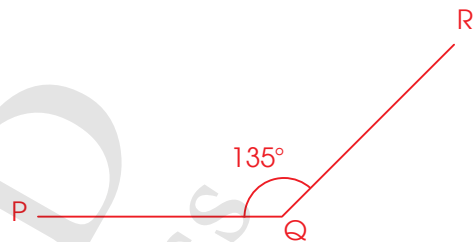

(c)



(d)

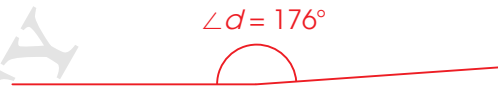

(e)

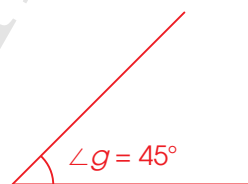

(f)

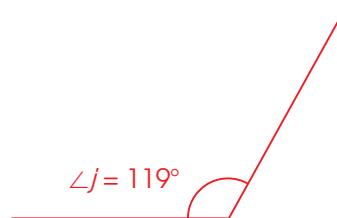

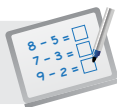
**Specific Learning Focus**

- Use notation such as $\angle ABC$ and $\angle a$ to name angles.
- Measure angles in degrees.
- Draw angles using a protractor.

Suggested Duration

Lesson 1: 2 periods

Lesson 2: 2 periods

Prior Learning

In Grade 3, pupils were introduced to angles and right angles as reference for identifying acute and obtuse angles. Remind pupils that when two line segments meet at a point, an angle is formed. In addition, recap with pupils that two lines that intersect at right angles are called perpendicular lines while two lines that never meet at a point no matter how long they are drawn are called parallel lines. It is good to revisit these facts before measuring and drawing angles using protractor.

Pre-emptive Pitfalls

The protractor as a geometric tool is introduced in this lesson. It has markings labelled on the inner and outer scales. When reading or constructing an angle, pupils tend to get confused as to when to read the inner scale and when to read the outer scale. To help them, ask them if the angle is larger or smaller than a right angle just by looking at the angle.

Introduction

Show an enlarged image of the protractor (Textbook 4 P107) on the visualiser and highlight the different parts of it: outer scale, inner scale, base line and centre of base line. Introduce the degree symbol “ $^{\circ}$ ” and explain to pupils that degrees is the unit of measure for angles. In Lesson 1, verbalise the steps involved when measuring angles using a protractor. In Lesson 2, verbalise the steps involved when drawing angles using a protractor.

Problem Solving

Before measuring or drawing an angle, identify acute and obtuse angles using the right angle as reference for comparison. Emphasise to pupils when the outer scale and inner scale of the protractor are to be used respectively when measuring angles. Ensure pupils have sufficient practice on measuring angles.

Activities

Provide each pupil with the diagrams of angles and ask pupils to work on the questions as independent seatwork.

Resources

- protractor
- ruler
- pencil
- diagrams of angles (Activity Handbook 4 P27)

Mathematical Communication Support

Use key terms like ‘right angle’, ‘acute angle’, ‘obtuse angle’, ‘base line’, ‘protractor’, ‘vertex’, ‘dot’, ‘straight line’, ‘inner scale’ and ‘outer scale’ while going through the steps of measuring and drawing angles.

LESSON

3

TURNS AND RIGHT ANGLES

LEARNING OBJECTIVE

1. Relate quarter, half and complete turns to angles in degrees.

URNS AND RIGHT ANGLES

LESSON 3

IN FOCUS



What angle does a minute hand make when it makes a complete turn?

LET'S LEARN



At 15 minutes, the minute hand makes $\frac{1}{4}$ of a complete turn.

$\frac{1}{4}$ of a complete turn is a right angle.

The minute hand makes an angle of 90° .



At 30 minutes, the minute hand makes $\frac{1}{2}$ of a complete turn.

The minute hand makes an angle of 180° .

The hands in a clock turn in the **clockwise** direction.

When a turn is made in the opposite direction, it turns in an **anticlockwise** direction.



115 CHAPTER 5

OXFORD UNIVERSITY PRESS

Textbook 4 P115

IN FOCUS

Using the question in In Focus, guide pupils to see that the amount of turn by the minute hand of a clock relates to an angle measured in degree. Pose the problem in In Focus to the pupils.

LET'S LEARN

Segment the clock face into 4 parts (12, 3, 6 and 9). Guide pupils to see that when the minute hand moves $\frac{1}{4}$ of a complete turn, 15 min have passed and this forms 1 right angle which is equal to 90° .

Repeat the same process with the second clock; making connection between $\frac{1}{2}$ of a complete turn, 30 min passed and a 180° angle.

Introduce the terms:

- Clockwise – the direction which the hour and minute hands turn.
- Anticlockwise – the opposite direction from which the hour and minute hands turn.



At 45 minutes, the minute hand makes $\frac{3}{4}$ of a complete turn.
The minute hand makes an angle of 270° .



At 60 minutes, the minute hand makes a complete turn.
The minute hand makes an angle of 360° .

PRACTICE



What are the angles formed?

(a)

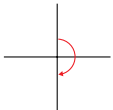

$\frac{1}{2}$ of a complete turn is 180° .

(b)

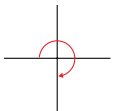

$\frac{3}{4}$ of a complete turn is 270° .

Complete Workbook 4A, Worksheet 3 • Pages 115 – 116

OXFORD
UNIVERSITY PRESS

ANGLES 116

Textbook 4 P116

Repeat the same process with the third clock; making connection between $\frac{3}{4}$ of a complete turn, 45 min passed and a 270° angle.

Repeat the same process with the fourth clock; making connection between a complete turn, 60 min (1 hour) passed and a 360° angle.

PRACTICE



Work with pupils on the practice questions.

Get pupils to answer and explain how they got their answers.

Independent seatwork

Assign pupils to complete Worksheet 3 (Workbook 4A P115 – 116).

Answers Worksheet 3 (Workbook 4A P115 – 116)

1. (a) $\frac{1}{4}$ of a complete turn = 90°
- (b) $\frac{1}{2}$ of a complete turn = 180°
- (c) $\frac{3}{4}$ of a complete turn = 270°
- (d) $\frac{1}{4}$ of a complete turn = 90°
- (e) $\frac{3}{4}$ of a complete turn = 270°
- (f) $\frac{1}{1}$ of a complete turn = 360°

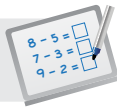
**Specific Learning Focus**

- Relate quarter, half and complete turns to angles in degrees.

Suggested Duration

2 periods

Prior Learning

Pupils have learnt clockwise and anticlockwise rotations, and half, full and quarter turns, in their earlier grades. They should understand that a turn is made about a point in a certain direction and the amount of turn can be measured in angles.

Pre-emptive Pitfalls

This chapter should be relatively easy for pupils. However, to help pupils understand the direction of turn better, ample practice is required.

Introduction

Segment the clock face into 4 parts. Link the fraction of a complete turn of the minute hand of the clock to the angle of turn and the amount of time that passed after the turn:

$\frac{1}{4}$ of a complete turn $\rightarrow 90^\circ$, 15 minutes

$\frac{1}{2}$ of a complete turn $\rightarrow 180^\circ$, 30 minutes

$\frac{3}{4}$ of a complete turn $\rightarrow 270^\circ$, 45 minutes

1 complete turn $\rightarrow 360^\circ$, 60 minutes

Problem Solving

Using the movement of a minute hand of a clock, relate fractions to angles and then to the number of minutes that passed. Explain to pupils the relationship.

Activities

Bring a clock to class and ask pupils to turn the minute hand according to the instructions given. Alternatively, the teacher may make a paper clock using a paper plate as the clock face and strips of cardboards as the clock hands, attached to the paper plate by a pin.

Resources

- Clock

Mathematical Communication Support

Ask pupils if the direction of the movement of the hands of the clock is clockwise or anticlockwise. Get pupils to verbalise their thoughts and discuss in class. Highlight to pupils that the prefix 'anti' means against the movement of the hands of a clock (which is clockwise). Draw the direction of the movement of the hands of a clock on the board and elicit individual responses by asking pupils for the direction, angle of turn and number of minutes passed.

LEARNING OBJECTIVES

1. Find angles (in degrees) between two 8-point compass directions.
2. Using an 8-point compass to name and describe directions.

8-POINT COMPASS

IN FOCUS

What is an 8-point compass used for?

LESSON

4

LET'S LEARN

1. An 8-point compass shows directions.

The angle between two lines is 45° .

Use 'Naughty Elephant Sprays Water' to remember the directions.

IN FOCUS

Make association between an 8-point compass and a clock face. Relate North, South, East and West to the 12, 3, 6 and 9 markings on the clock face.

LET'S LEARN

Next introduce the other four points using Let's Learn 1. Highlight that the angles between two 8-points compass is 45° . Help pupils remember the sequence with the acronym 'Naughty Elephant Sprays Water'.

2. Ann is standing at A.

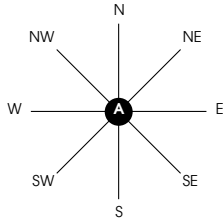

- (a) Ann is facing north.
If she turns 90° clockwise, she will face east.
- (b) Ann is facing north.
If she turns 45° clockwise, she will face northeast.
- (c) Ann is facing south.
If she turns 90° anticlockwise, she will face east.
- (d) Ann is facing west.
If she turns 135° anticlockwise, she will face southeast.

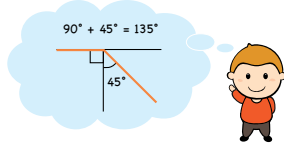

OXFORD
UNIVERSITY PRESS

ANGLES 118

Textbook 4 P118

For Let's Learn 2, project the 8-point compass on the screen. Mark out where Ann is facing (north).

For 2(a), get pupils to highlight or underline the key elements (90° and clockwise). Then demonstrate the turn Ann made to face east.

For 2(b), repeat the same process as 2(a).

For 2(c), allow pupils to read the question silently and highlight important elements. Then get a pupil to mark out Ann's position (South). Next demonstrate the 90° anticlockwise turn.

For 2(d), allow pupils to read the questions silently to highlight important elements and mark out Ann's position. Next, explain that $90^\circ + 45^\circ = 135^\circ$ and demonstrate the turn that Ann made.

3. A map of Priya's neighbourhood is shown below.

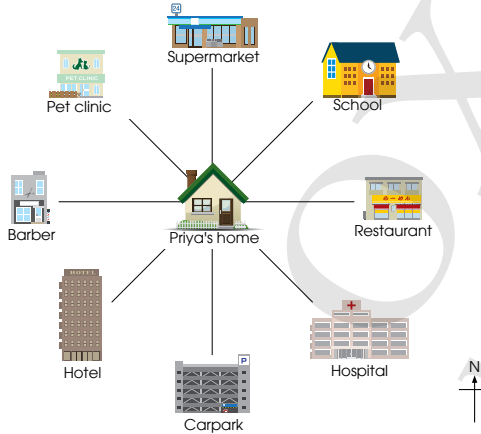

119 CHAPTER 5

OXFORD
UNIVERSITY PRESS

Project the map in Let's Learn 3 on the screen. Highlight the legend and its function to the class. For class discussion, identify the 8-point directions on the map.

Textbook 4 P119

- (a) We can tell the direction of a place from Priya's home.

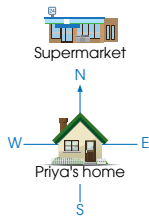

The supermarket is north of Priya's home.

- (b) We can also tell the direction of Priya's home from other places.

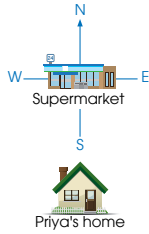

Priya's home is south of the supermarket.

Compare the two ways of telling position.

What is the difference in the directions? How are the directions related?



OXFORD
UNIVERSITY PRESS

ANGLES 120

Textbook 4 P120

For 3(a), ask pupils what is behind Priya's home (supermarket). Next guide the pupils to see that the supermarket is north of Priya's home.

For 3(b), ask pupils what direction is Priya's home from the supermarket. Guide pupils to see that her home is south of the supermarket. For class discussion, ask pupils what is the difference in the two ways of telling direction (3(a) and 3(b)) and how are the directions related.

PRACTICE



1. The spinner below shows 8 compass points. Find the directions that the needle will point to after spinning.

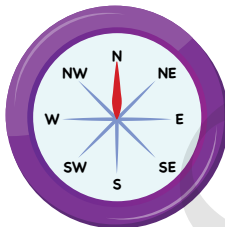

- (a) The needle is pointing north.
It will point **south** when it turns 180° clockwise.
- (b) The needle is pointing southwest.
It will point **north** when it turns 225° anticlockwise.
- (c) The needle points south after it turns 90° clockwise.
It was pointing **east**.
- (d) The needle points northeast after it turns 45° anticlockwise.
It was pointing **east**.

121 CHAPTER 5

OXFORD
UNIVERSITY PRESS

Textbook 4 P121

PRACTICE



Work through the practice question 1 with the pupils.

2. Look at the picture and answer the following questions.

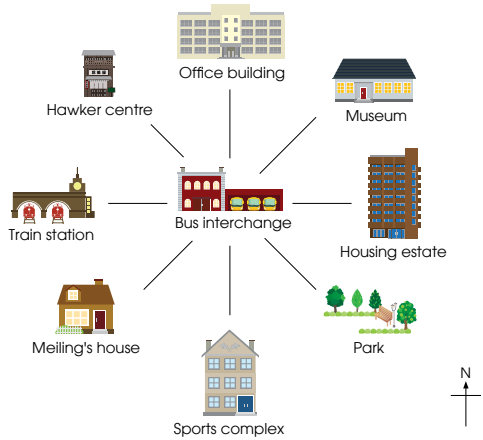

- (a) The housing estate is **east** of the bus interchange.
 (b) Meiling's house is **southwest** of the bus interchange.
 (c) The park is **southeast** of the bus interchange.
 (d) The bus interchange is **southeast** of the hawker centre.
 (e) The bus interchange is **southwest** of the museum.
 (f) The bus interchange is **south** of the office building.

Complete Workbook 4A, Worksheet 4 • Pages 117 – 119

OXFORD
UNIVERSITY PRESS

ANGLES

122

Textbook 4 P122

For practice question 2, explain that the reference point is the place mentioned at the end of the sentence after the word 'of' ("... of the ___").

To help pupils visualise, teacher may superimpose an 8-point compass on top of the picture. Work with pupils on the questions, allowing pupils to come forward to explain their answers.

Independent seatwork

Assign pupils to complete Worksheet 4 (Workbook 4A P117 – 119).

Answers Worksheet 4 (Workbook 4A P117 – 119)

1.

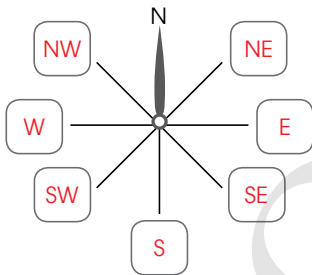

- (a) east
 (b) east
 (c) west
 (d) north

2. (a) east
 (b) south
 (c) north
 (d) south

3. (a) southwest
 (b) south
 (c) northeast
 (d) south
 (e) west
 (f) east
 (g) northwest

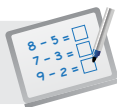

Specific Learning Focus

- Find angles (in degrees) between two 8-point compass directions.
- Use an 8-point compass to name and describe directions.

Suggested Duration

4 periods

Prior Learning

The 8-point compass is introduced to pupils in this lesson. They should be well-versed with turns in the clockwise and anticlockwise directions.

Pre-emptive Pitfalls

This lesson is a continuation of the lessons on angles and turns.

Introduction

Introduce the directions on an 8-point compass by explaining that if Ann is facing north:

amount of turn (in clockwise direction)	angle of turn	direction Ann will face after the turn
quarter	90°	East (E)
half	180°	South (S)
3 quarters	270°	West (W)
1 complete turn	360°	North (N)

Highlight to pupils that Northeast (NE) is exactly in between N and E, Southeast (SE) is exactly in between S and E, Southwest is exactly in between S and W, and Northwest is exactly in between N and W.

Therefore, if Ann is facing north, she needs to turn the following angles in order to face the following directions:

angle of turn (in clockwise direction)	direction Ann will face after the turn
45° (half of 90°)	NE
135° [90° (1 quarter) + 45°]	SE
225° [180° (2 quarters) + 45°]	SW
315° [270° (3 quarters) + 45°]	NW

Problem Solving

In this lesson, pupils are introduced informally to bearings and vectors. It is imperative that calculations and representations of direction and angle of turning are grasped.

Activities

Draw a simplified floor plan of the school and work with pupils the amount of turn we should make to face places like the auditorium, school canteen, library, etc., given that we are facing the classroom.

Resources

- 8-point compass [actual or cut-out (Activity Handbook 4 P28)]

Mathematical Communication Support

Verbalise each question in 'Let's Learn' and 'Practice' (Textbook 4 P117, 121). Have pupils use key terms like 'clockwise', 'anticlockwise', 'Northeast', 'Northwest', 'Southeast', 'Southwest' when discussing the answers.

PROBLEM SOLVING, MATHS JOURNAL AND PUPIL REVIEW



MIND WORKOUT

Kate is playing a game.
She has to move the bee along the lines to get to the flowers.
How can Kate move the bee from the starting point to reach the flowers?

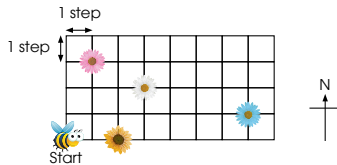

You need to first state the number of steps before giving the direction.



- (a) To reach the yellow flower, the bee has to move 2 steps east.
- (b) To reach the pink flower, the bee has to move 3 steps north and 1 step east.
- (c) To reach the white flower, the bee has to move 2 steps north and 3 steps east.
- (d) To reach the blue flower, the bee has to move 1 step north and 7 steps east.

Are there other ways to move the bee to each flower?



MIND WORKOUT

The activity shows another way in which directions can be depicted. The bee can only move along the horizontal and vertical lines. To calculate the number of steps, count the number of squares it passes.



Mind Workout

Date: _____

Move along the lines to reach the treasure chests.
Some paths are blocked by squares.
What is the shortest path you can take to get all the treasure chests?

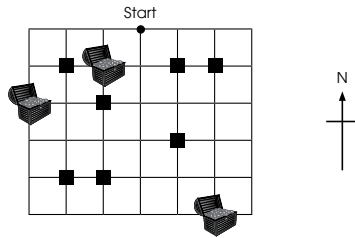

1 step south, 1 step west, 1 step north, 2 steps west, 2 steps south.

3 steps south, 5 steps east

Workbook 4A P120



Mind Workout

This Mind Workout is an extension of the Mind Workout in the Textbook (P123). The addition of obstacles adds challenges to the workout.

MATHS JOURNAL

What are the positions of your classmates' seats from your seat?
Draw to show the seating positions of your classmates.
Describe the positions of each of your classmates to your class.

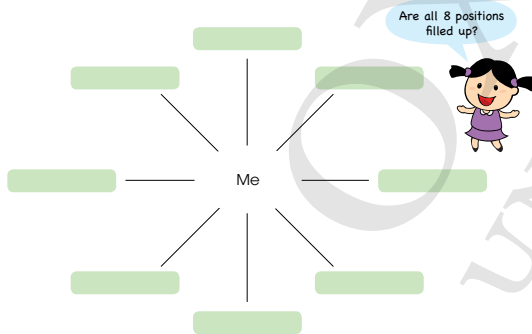

I know how to...

- name, measure and draw an angle.
- relate turns to angles in degrees.
- use an 8-point compass to state directions.

SELF-CHECK



Textbook 4 P124

MATHS JOURNAL

This activity requires pupils to relate their seating arrangement in the class using the 8-point compass. Teacher may facilitate by showing the top view of the class' seating plan and illustrate with an example before getting pupils to work on their own.

Before the pupils do the self-check, review the important concepts once more by asking for examples learnt for each objective.

SELF-CHECK



This self-check can be done after pupils have completed **Review 5** (Workbook P121 – 124) as consolidation of understanding for the chapter.

1. (a) $\angle q = 73^\circ$
(72° and 74° can be accepted)
- (b) $\angle JKL = 142^\circ$
(141° and 143° can be accepted)
- (c) $\angle r = 84^\circ$
(83° and 85° can be accepted)
- (d) $\angle LMN = 121^\circ$
(120° and 122° can be accepted)

2. (a)

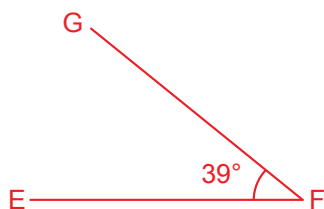

- (b)

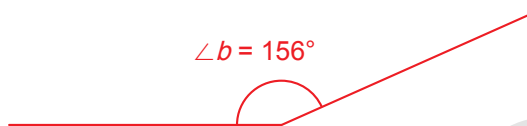

3. (a) $\frac{3}{4}$ of a complete turn = 270°
- (b) $\frac{1}{2}$ of a complete turn = 180°

- 4.

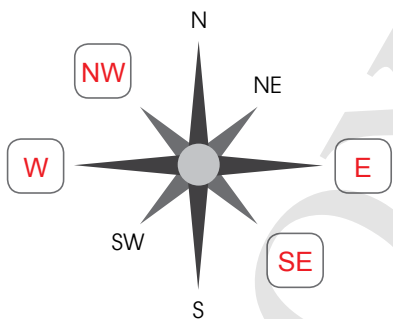

- (a) northeast
 - (b) north
 - (c) northeast
 - (d) southeast
 - (e) 225°
5. (a) northwest
 - (b) southwest
 - (c) south
 - (d) hawker center
 - (e) MRT station
 - (f) hospital

TRANSLATION AND TESSELLATIONS

CHAPTER 6

Translation and Tessellations

CHAPTER
6

Do you play chess?
Do you know how to describe how a chess piece moves from one square of the chessboard to the next?



TRANSLATION

IN  FOCUS

LESSON
1

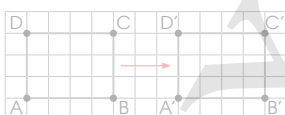

Can you describe how to move rectangle ABCD to A'B'C'D'?

125 CHAPTER 6

OXFORD
UNIVERSITY PRESS

Textbook 4 P125

Related Resources

NSPM Textbook 4 (P125 – 131)
NSPM Workbook 4A (P125 – 130)

Materials

Square grid paper, markers, chessboard, chess pieces, shapes for tessellations, scissors, tape, drawing block

Lesson

Lesson 1 Translation
Lesson 2 Recognising Tessellations
Problem Solving, Maths Journal and Pupil Review

INTRODUCTION

Pupils are introduced to translation and tessellation for the first time in this chapter. In this chapter, pupils will learn to describe the movement of an object in terms of translation. They also learn to draw the shape after a translation, and recognise and make tessellations.

LESSON

1

TRANSLATION

LEARNING OBJECTIVES

1. Describe the translation of an object in terms of units.

Translation and Tessellations

Do you play chess?
Do you know how to describe how a chess piece moves from one square of the chessboard to the next?



CHAPTER

6

TRANSLATION

IN  FOCUS



Can you describe how to move rectangle ABCD to A'B'C'D'?

LESSON

1

125 CHAPTER 6

OXFORD UNIVERSITY PRESS

Textbook 4 P125

IN FOCUS

Using the chapter opener, ask pupils to discuss ways to describe the movement of a chess piece from one square of the chessboard to the next.

Referring to the points on the square grid, ask:

- In which direction did the rectangle move?
- How can the distance that the rectangle moved be described using square grid?

LET'S LEARN

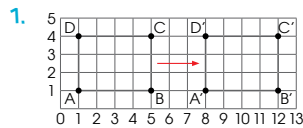

1. Rectangle ABCD is moved 7 units to the right to obtain A'B'C'D'. We say that ABCD is **translated** 7 units to the right.

Translation does not change the shape and size of the figure.

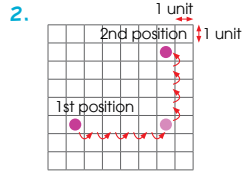

2. **Step 1** Count the number of squares along the horizontal grid.

Step 2 Count the number of squares along the vertical grid.

From the 1st position, the counter is translated 5 units to the right and 4 units to the top.

Can we say that the counter is translated 4 units to the top and 5 units to the right?

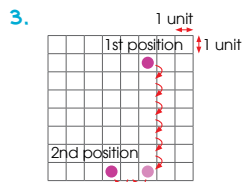

3. From the 1st position, the counter is translated 6 units to the bottom and 2 units to the left.

Is there another way to obtain the answer?



OXFORD UNIVERSITY PRESS

TRANSLATION AND TESSELLATIONS

126

Textbook 4 P126

LET'S LEARN

For Let's Learn 1, lead pupils to see that rectangle ABCD is moved to the right to obtain A'B'C'D'. Guide them to count the number of units that the rectangle is moved by shading each square each time it is being counted. Explain to them that translation does not change the shape and size of the figure.

For Let's Learn 2, explain to pupils that the counter is translated in two directions, so to describe the translation, two steps are required. Lead them to see that in the first step, the number of squares must be counted along the horizontal grid as the counter is moved to the right. In the second step, the number of squares must be counted along the vertical grid as the counter is moved to the top. Ask them if there is another way to describe the translation.

For Let's Learn 3, guide pupils to count the number of squares along the vertical grid as the counter is moved to the bottom, and then count the number of squares along the horizontal grid as the counter is moved to the left. Ask them if there is another way to obtain the answer.

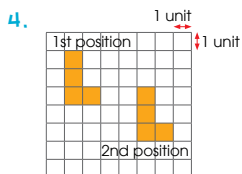

4. From the 1st position, the shape is translated 4 units to the right and 2 units to the bottom.

PRACTICE



1. Describe how the counter is moved from the first position to the second position.

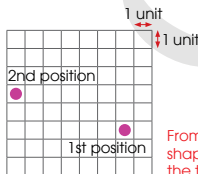

From the first position, the shape is translated 2 units to the top and 6 units to the left.

2. Draw the shape after it has been translated 3 units to the left and 1 unit to the top.

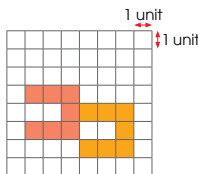

Complete Workbook 4A, Worksheet 1 • Pages 125 – 126

127

CHAPTER 6

OXFORD UNIVERSITY PRESS

Textbook 4 P127

PRACTICE



Work with pupils on the questions and selected examples from **Worksheet 1**.

Independent seatwork

Assign pupils to complete Worksheet 1 (Workbook 4A P125 – 126).

- (a) No
(b) Yes
- From the first position, the shape is translated 4 units to the bottom and 2 units to the left.

From the first position, the shape is translated 2 units to the left and 4 units to the bottom.

OXFORD
UNIVERSITY PRESS

**Specific Learning Focus**

- Describe the translation of an object in terms of units.

Suggested Duration

2 periods

Prior Learning

This chapter is a progression of the chapters on turns, directions and symmetry, which were learnt previously.

Pre-emptive Pitfalls

Translation is a new concept that has not been introduced before. The movement of a chess piece on a chessboard (as shown in the chapter opener) can be used to help pupils understand the concept of translation. This example would help pupils relate to the concept better.

Introduction

Introduce to pupils that the translation of a figure is a movement (in the direction to the right, left, up or down) of the figure along a straight line that does not change the shape and size of the figure. In Let's Learn 1 (Textbook 4 P126), point out to pupils that each vertex of rectangle ABCD is marked out with a point and labelled with an uppercase letter. Therefore, the translated figure is labelled as A'B'C'D'. Emphasise to pupils that translation does not change the shape and size of the figure. Explain that to describe the movement of a translation of a figure,

- for horizontal movement, count the number of squares along the horizontal grid (to the right or left);
- for vertical movement, count the number of squares along the vertical grid (to the top or bottom).

Problem Solving

Remind pupils that it is important to state if the counting of squares is to be done along the horizontal or vertical grid when describing the movement or when obtaining the translated figure.

Activities

Provide pupils with square grid papers and get them to draw triangles and squares, and translate them according to the instructions written on the board. The teacher may bring a chessboard and chess pieces to the class, and show how chess is played while describing the movements of the chess pieces as translations.

Resources

- square grid paper
- translation of counter and shape on square grid (Activity Handbook 4 P29)
- markers
- chessboard
- chess pieces

Mathematical Communication Support

Show a square grid paper on the visualiser or draw a square grid on the board. Describe verbally the translation of a point along the horizontal grid and then along the vertical grid, or the other way around, and prompt pupils to say where the translated point is located. Emphasise to pupils that similar to grid reference, it must be mentioned whether the movement is along the horizontal or vertical grid, in order to locate the position of the point after translation. Also, remind pupils that translation is a movement in the direction of right or left, and/or up or down.

RECOGNISING TESSELLATIONS

LEARNING OBJECTIVES

1. Recognise if a pattern is a tessellation.
2. Make tessellations using the given shapes.

RECOGNISING TESSELLATIONS

IN FOCUS

Look at the pattern.
What do you notice?

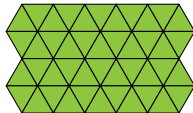

LET'S LEARN

1.

Triangles of the same size form this pattern.

There are no gaps in between the triangles.

The triangles do not overlap each other.



The tessellation is made of only one shape.
The unit shape that is used in this tessellation is .

2.

Look at the patterns below. They are made of shapes of the same size. Are they tessellations?

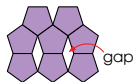

There are gaps in between the shapes.
The pattern is not a tessellation.

IN FOCUS

Ask pupils to look at the pattern and describe what pattern they notice.

LET'S LEARN

For Let's Learn 1, guide pupils to see that triangles of the same size form this pattern without any gaps in between the triangles, and the triangles do not overlap each other. Explain to pupils that this pattern is an example of tessellation and the unit shape used in this tessellation is a triangle.

For Let's Learn 2, explain to pupils that when there are gaps in between the shapes, or when the shapes overlap each other, the pattern is not a tessellation.

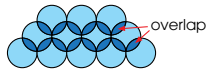

The shapes overlap each other.
The pattern is not a tessellation.

3.



The unit shape that is used in this tessellation is .

4. Which of the 3 shapes below can we use to make tessellations?

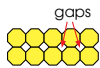

Shape X does not tessellate.

Shapes Y and Z tessellate in different ways.
We can make different tessellations using shapes Y and Z.

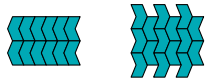

Can you think of other ways?

We can make cut-outs of each of the shapes and check if they can make tessellations.



129 CHAPTER 6

OXFORD UNIVERSITY PRESS

Textbook 4 P129

For Let's Learn 3, ask pupils to identify the shape that repeats in this tessellation. Explain to them that the shape that repeats is the unit shape.

For Let's Learn 4, guide pupils to make tessellations given the shapes. Lead them to see that some shapes can tessellate in more than one way. Ask them if they can think of other ways that shapes Y and Z can tessellate.

Work in pairs.

1.



Start with a square. Cut a shape from one side of the square and tape it on the opposite side directly across from the cut-out.

2.



Cut the shape into two parts and then tape them opposite each other as shown. This is your tessellating shape!

Try designing figures from other tessellating shapes and create tessellations with them.



ACTIVITY TIME

What you need:



ACTIVITY TIME



Working in pairs, pupils will practise designing figures from different tessellating shapes and create tessellations with them.

PRACTICE

1. Identify the unit shape in each tessellation.

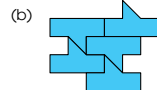

2. Which of the following are tessellations? (a) and (d)

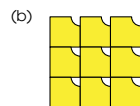
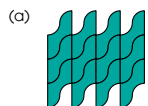

OXFORD UNIVERSITY PRESS

TRANSLATION AND TESSELLATIONS

130

PRACTICE



Work with pupils on the practice questions.

For better understanding, select items from **Worksheet 2** and work these out with the pupils.

Textbook 4 P130

Independent seatwork

Assign pupils to complete Worksheet 2 (Workbook 4A P127).

(c)



(d)

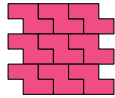

Complete Workbook 4A, Worksheet 2 • Page 127



MIND WORKOUT

Make copies of the shapes and use them to find which shapes tessellate.



MATHS JOURNAL

Make copies of the shapes and show at least two different ways to tessellate them.

(a)



(b)



Share the patterns you made with the class.

I know how to...

- translate shapes on a square grid.
- recognise tessellations.

SELF-CHECK

131

CHAPTER 6

OXFORD UNIVERSITY PRESS

Textbook 4 P131

Answers Worksheet 2 (Workbook 4A P127)

1. (a)

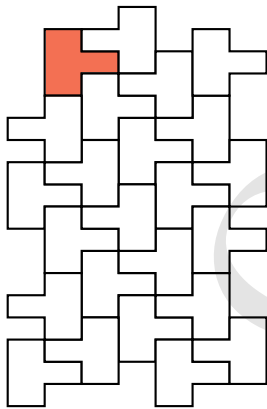

2. (a) Yes

(b) No

(b)

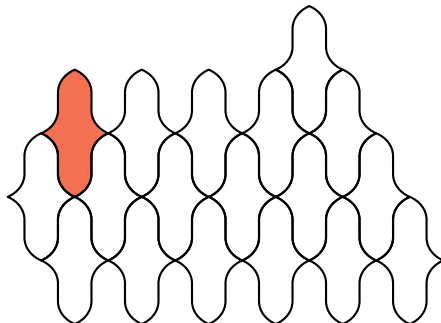

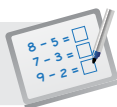
**Specific Learning Focus**

- Recognise if a pattern is a tessellation.
- Make tessellations using the given shapes.

Suggested Duration

2 periods

Prior Learning

Tessellation is a new concept that pupils learn in this lesson. Pupils should be familiar with two-dimensional shapes and their names.

Pre-emptive Pitfalls

This lesson should be a relatively easy lesson and can be made fun with hands-on activities.

Introduction

Introduce tessellation to pupils as a pattern made by repeating the same shape without overlapping each other and without any gaps in between. Emphasise that if there are gaps between the shapes, or when the shapes overlap each other, the pattern is not a tessellation.

Problem Solving

Recap with pupils the names of various two-dimensional shapes and talk about shape patterns in real life (e.g. arrangement of the floor tiles).

Activities

Provide pupils with shape cut-outs and let them do independent seatwork. Ask them to repeat the pattern like a jigsaw puzzle and determine if they are tessellations based on whether there are gaps in between the shapes and whether the shapes overlap each other.

Resources

- shapes for tessellations (Activity Handbook 4 P30 – 31)
- scissors
- tape
- drawing block

Mathematical Communication Support

Key terms of tessellation such as 'gaps', names of two-dimensional shapes, etc., can be verbalised in class while pupils do independent seatwork and hands-on activities.

PROBLEM SOLVING, MATHS JOURNAL AND PUPIL REVIEW



Mind Workout

Ann says that these shapes do not tessellate.



Do you agree with her? Why?

128 Chapter 6

OXFORD
UNIVERSITY PRESS



Mind Workout

Get pupils to draw the shapes and see if the shapes can be tessellated. Remind them that if the shape can form a pattern without any gaps in between and without overlapping each other, the shape tessellates.

Workbook 4A P128

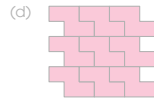
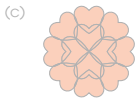

Complete Workbook 4A, Worksheet 2 • Page 127

MIND WORKOUT

Make copies of the shapes and use them to find which shapes tessellate.

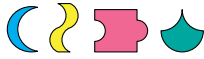

MATHS JOURNAL

Make copies of the shapes and show at least two different ways to tessellate them.

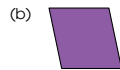
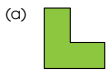

Share the patterns you made with the class.

I know how to...

- translate shapes on a square grid.
- recognise tessellations.



MIND WORKOUT

Get pupils to cut out the shapes and see if they can tessellate. Encourage them to explain why they can or cannot tessellate.

MATHS JOURNAL

Get pupils to cut out the shapes and show at least two different ways to tessellate them. Have them share the patterns they made with the class.

SELF-CHECK



The self-check can be done after pupils have completed **Review 6** (Workbook 4A P129 – 130).

Answers Review 6 (Workbook 4A P129 – 130)

1. From the first position, the counter is translated 4 units to the bottom and 5 units to the left.

2.

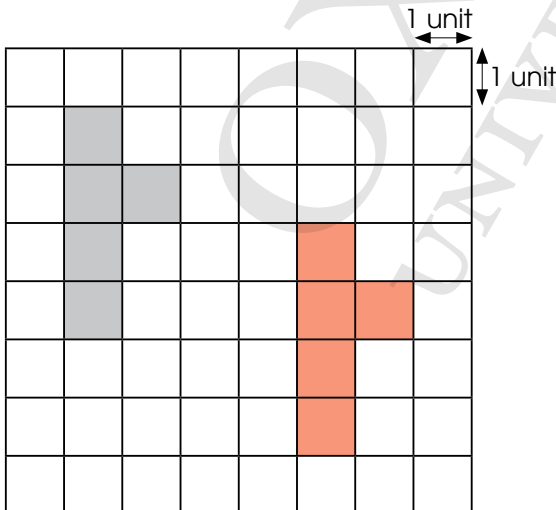

3.

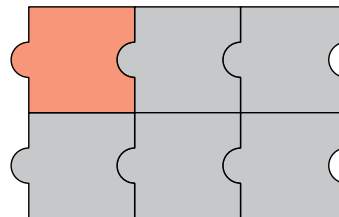

4. (a) Yes
(b) No

SQUARES AND RECTANGLES

CHAPTER 7

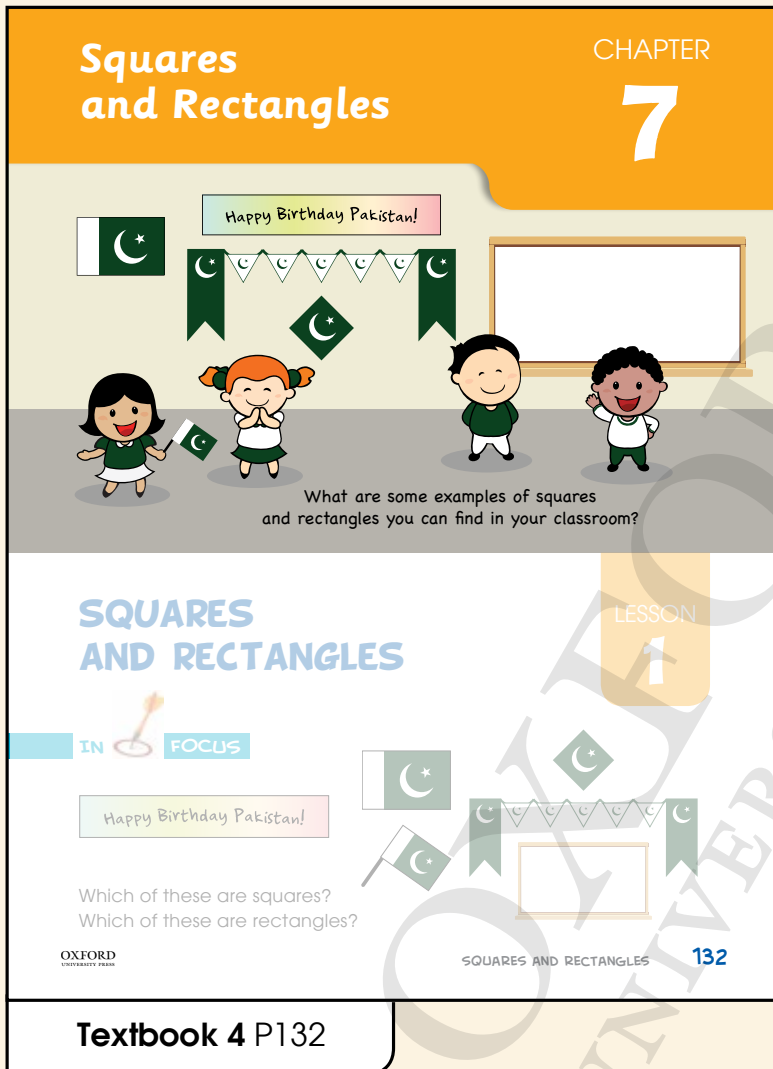

Related Resources

NSPM Textbook 4 (P132 – 147)
NSPM Workbook 4A (P131 – 142)

Materials

Square grid paper, protractor, set squares, ruler, play cards (see Activity Handbook 4)

Lesson

Lesson 1 Squares and Rectangles
Lesson 2 Drawing Squares and Rectangles
Problem Solving, Maths Journal and Pupil Review

INTRODUCTION

In Grades Two and Three, pupils have learnt to recognise basic shapes including squares and rectangles. At Grade Four, pupils' understanding of squares and rectangles will be based on the analysis of their mathematical properties. They will describe squares and rectangles using terms like 'perpendicular lines', 'parallel lines' and 'right angles'. After which pupils will learn to draw these shapes on square grid papers and also according to a given dimension using ruler, protractor and set squares.

LESSON

1

SQUARES AND RECTANGLES

LEARNING OBJECTIVE

1. Recognise the properties of rectangles and squares.

Squares and Rectangles CHAPTER 7

Happy Birthday Pakistan!

What are some examples of squares and rectangles you can find in your classroom?

SQUARES AND RECTANGLES LESSON 1

IN FOCUS

Happy Birthday Pakistan!

Which of these are squares?
Which of these are rectangles?

OXFORD UNIVERSITY PRESS

SQUARES AND RECTANGLES 132

Textbook 4 P132

IN FOCUS

Using the Chapter Opener, ask pupils to identify the squares and rectangle and explain how they identify the figures. Do not correct their responses. Instead, direct them from defining the shapes perceptually to recognising the perpendicular and parallel lines and right angles in each figure.

1. A square has four sides.

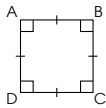

We use the short lines to show that the sides are equal.



All four sides are equal in length.
 $AB = BC = CD = DA$

All angles are equal to 90° .
 $\angle ABC = \angle BCD = \angle CDA = \angle DAB = 90^\circ$

What do you notice about AB and DC?

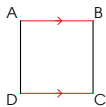

AB and DC are parallel to each other.
 $AB \parallel DC$

Can you see another pair of parallel lines?

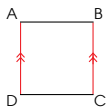

AD and BC are also parallel to each other.
 $AD \parallel BC$
 The opposite sides of a square are parallel to each other.

Which pairs of lines are perpendicular to each other?



What is the difference between \rightarrow and \uparrow ?



Using Let's Learn 1, list the properties of the square.

- It has four equal sides.
 Guide pupils to list the four sides then introduce the mathematical symbols to represent this property ($AB = BC = CD = DA$). Introduce the short lines as symbols to indicate that the sides are equal.
- All angles are equal to 90° .
 Guide pupils to list the four angles ($\angle ABC = \angle BCD = \angle CDA = \angle DAB = 90^\circ$).
 Since all angles are right angles, lead pupils to see that $AB \perp BC$, $BC \perp CD$, $CD \perp DA$ and $DA \perp AB$.
- The opposite sides are parallel to each other.
 Guide pupils to list the two pairs of parallel lines ($AB \parallel DC$, $BC \parallel AD$). Introduce the arrowheads as symbols to indicate that the lines are parallel to each other. Explain how the different pairs of parallel lines are distinguished with the use of two arrowheads.

2. A rectangle has four sides.

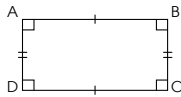

The opposite sides are equal in length.
 $AB = DC$, $AD = BC$

All angles are equal to 90° .
 $\angle ABC = \angle BCD = \angle CDA = \angle DAB = 90^\circ$

What do you notice about the sides?

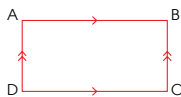

AB and DC are parallel to each other.
 $AB \parallel DC$
 AD and BC are also parallel to each other.
 $AD \parallel BC$

The opposite sides of a rectangle are parallel to each other.

Which pairs of lines are perpendicular to each other?



Rectangles and squares are similar, but rectangles are not squares.



Are squares also rectangles?

For Let's Learn 2, repeat the same process as Let's Learn 1, but get pupils to list the equal sides, the perpendicular lines and parallel lines.

For class discussion, ask pupils if rectangles and squares are similar and if squares are special rectangles?

3. Figure PQRS is a square.

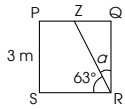

- (a) The length of SR is 3 m.
 (b) $PQ \parallel SR$
 (c) $\angle \alpha = 27^\circ$

Recall that $\angle QRS = 90^\circ$.
 $63^\circ + \angle \alpha = 90^\circ$



4. Figure WXYZ is a rectangle.

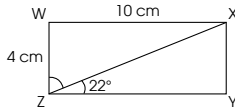

- (a) The length of XY is 4 cm.
 (b) The length of YZ is 10 cm.
 (c) $WX \parallel ZY$, $XY \parallel WZ$
 (d) $\angle WZX = 68^\circ$

PRACTICE



1. Which of these are squares? B, C
 Explain your answer.

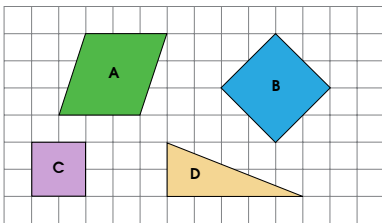

135 CHAPTER 7

OXFORD UNIVERSITY PRESS

Textbook 4 P135

Work with the class to fill in the blanks in Let's Learn 3. Get pupils to state the properties they applied.

Repeat the same process for Let's Learn 4.

PRACTICE



For practice question 1, demonstrate the steps in identifying the squares.

2. Which of these are rectangles? B, C
 Explain your answer.

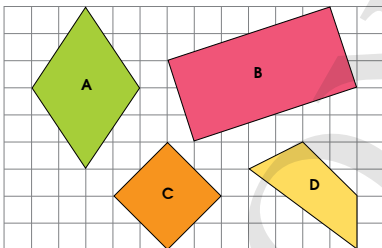

3. Figure ABCD is a square and Figure EFGH is a rectangle.

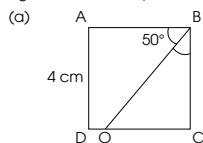

- $AB = 4$ cm
 $AD \parallel BC$
 $\angle OBC = 40^\circ$

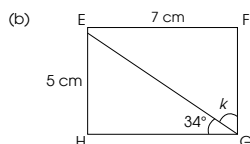

- $FG = 5$ cm
 $FG \perp HG$
 $\angle k = 56^\circ$

Complete Workbook 4A, Worksheet 1 • Pages 131 – 134

OXFORD UNIVERSITY PRESS

SQUARES AND RECTANGLES

136

Textbook 4 P136

Allow pupils to work in pairs for practice questions 2 and 3. Then get pupils to present their answers and reasoning for each answer.

Independent seatwork

Assign pupils to complete Worksheet 1 (Workbook 4A P131 – 134).

1.

Figure	A	B	C	D	E
It has four sides.	✓	✓	✓	✓	✓
All sides are of the same length.	✓	✓		✓	
The opposite sides are parallel to each other.	✓	✓		✓	
It has four angles.	✓	✓	✓	✓	✓
All four angles are equal to 90° .		✓		✓	
It is a square.		✓		✓	

2.

Figure	A	B	C	D	E
It has four sides.	✓	✓	✓	✓	✓
The opposite sides are of the same length.	✓	✓	✓	✓	
The opposite sides are parallel to each other.	✓	✓	✓	✓	
It has four angles.	✓	✓	✓	✓	✓
All four angles are equal to 90° .	✓		✓	✓	
It is a rectangle.	✓		✓	✓	

3. (a) 5
(b) CD
(c) 45
4. (a) 8
(b) HG, FG
(c) 34
5. (a) 3
(b) 7
(c) SR, SR
(d) 23
6. (a) 4
(b) 6
(c) XY, WX
(d) 33

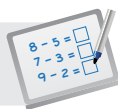

Specific Learning Focus

- Recognise the properties of rectangles and squares.

Suggested Duration

4 periods

Prior Learning

Pupils should be familiar with 4-sided shapes like squares and rectangles, and should be able to differentiate between a square and a rectangle based on their dimensions.

Pre-emptive Pitfalls

Although pupils should be able to recognise and identify squares and rectangles, it might be challenging for pupils to relate and link the concepts together, which is required in this chapter through the spiral approach.

Introduction

Introduce or recap the following symbols with the pupils:

- first set of parallel lines \rightleftarrows
- second set of parallel lines \updownarrow
- perpendicular lines \perp
- equal sides 

Through experiential learning, get pupils to draw a square ABCD on a square grid and ask them to identify the properties of the square:

- all four sides are equal in length ($AB = BC = CD = DA$)
- all angles are equal to 90° ($\angle ABC = \angle BCD = \angle CDA = \angle DAB = 90^\circ$)
- there are 2 pairs of parallel lines ($AB \parallel DC, AD \parallel BC$)
- there are 4 pairs of perpendicular lines ($AB \perp AD, BC \perp AB, CD \perp AD, BC \perp CD$)

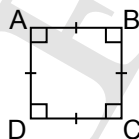

Similarly, get pupils to draw a rectangle ABCD on a square grid and ask them to identify the properties of the rectangle:

- the opposite sides are equal in length ($AB = DC, AD = BC$)
- all angles are equal to 90° ($\angle ABC = \angle BCD = \angle CDA = \angle DAB = 90^\circ$)
- there are 2 pairs of parallel lines ($AB \parallel DC, AD \parallel BC$)
- there are 4 pairs of perpendicular lines ($AB \perp AD, BC \perp AB, CD \perp AD, BC \perp CD$)

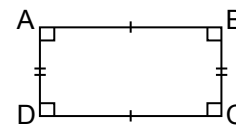

Based on the properties listed, explain to pupils that a square is also a rectangle since all the properties of a rectangle are properties of a square too. However, it should be pointed out that a rectangle is not a square.

Problem Solving

Get pupils to learn and remember the properties of squares and rectangles. Ask them to attempt the questions in 'Let's Learn' (Textbook 4 P135) and 'Practice' (Textbook 4 P135 – 136), as well as in Worksheet 1 (Workbook 4A P131 – 134).

Activities

Provide each pupil with shape cut-outs and ask pupils to identify squares and rectangles, and use mathematical reasoning to explain, with the help of symbols (\parallel and \perp).

Resources

- shapes (Activity Handbook 4 P32 – 33)
- square grid paper (Activity Handbook 4 P24)

Mathematical Communication Support

Verbalise with pupils the properties of a square and a rectangle, and ask important questions leading to mathematical reasoning to justify the identification of a square and a rectangle respectively. Prompt them by asking questions like 'Are all the sides equal in length?', 'Are the sides parallel to each other?', 'Are all the angles 90° ?'

DRAWING SQUARES AND RECTANGLES

LEARNING OBJECTIVES

1. Draw rectangles and squares on square grid paper and according to a given dimension using protractors, ruler and set squares.
2. Observe the different orientations of a rectangle when it is rotated.

DRAWING SQUARES AND RECTANGLES

LESSON
2

IN  FOCUS

The 1-cm square grid shows incomplete drawings of Figures ABCD and EFGH.

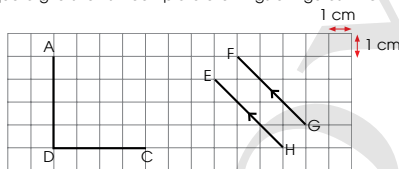
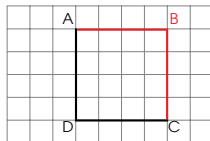

Figure ABCD is a square and Figure EFGH is a rectangle. How do we complete the drawings?

LET'S LEARN 

1. Recall what we learned about squares and rectangles.
 - (a) All four sides of a square are equal in length. The opposite sides of a square are parallel to each other. Each angle in the square is equal to 90° .



IN  FOCUS

Ask pupils what properties they should apply to complete Figure ABCD and Figure EFGH.

LET'S LEARN 

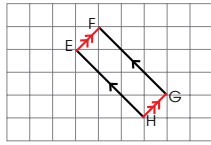

Using Let's Learn 1(a), demonstrate to the class how Figure ABCD can be completed. For each step, get pupils to state the properties.

- (b) The opposite sides of a rectangle are equal in length.
The opposite sides of a rectangle are also parallel to each other.
It has 4 angles and each angle is equal to 90° .



ACTIVITY  **TIME**

Work in pairs.

- 1 Draw and label a square or a rectangle on .
- 2 Ask your partner to check if the shape is drawn and labelled correctly.
Check by using a  and a .
- 3 Take turns and repeat 1 to 2.

What you need:



Try drawing each shape in different orientations.



Textbook 4 P138

Repeat the same process for Let's Learn 1(b).

ACTIVITY  **TIME**

Pupils will work in pairs to have a hands-on experience in drawing a square or rectangle on the square grid. They will apply their knowledge of the properties of squares and rectangles when checking their partner's drawing.

2. Figure KLMN is a square of side 3 cm.
Draw and label Figure KLMN.

Make a sketch of Figure KLMN before drawing.



- Step 1** Draw a straight line measuring 3 cm.
Label the line NM.

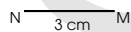

- Step 2** Place a ruler and a set square on NM as shown.
Draw two lines perpendicular to NM at point N and point M.

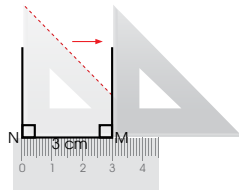
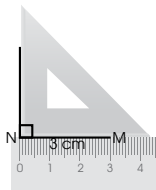

Textbook 4 P139

Get pupils to do a sketch of Figure KLMN first. Using the visualiser, demonstrate the steps in drawing Figure KLMN of Let's Learn 2. After each step, allow pupils to work in pairs to do the construction.

Ensure that pupils take turns to practice.

- Step 3** Use a ruler to measure 3 cm from point N. Make a mark and label the point K. Mark out point L by repeating the steps from point M.

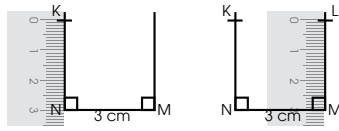

- Step 4** Use a ruler to join point K and point L. Complete your drawing by labelling the figure.

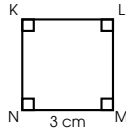

Does your sketch match the drawing?



Textbook 4 P140

Remind pupils to complete the drawing by labeling the figure. Then get pupils to check their drawing against the sketch.

3. Figure PQRS is a rectangle, with $PQ = 5$ cm and $QR = 2$ cm. Draw and label Figure PQRS.

Make a sketch of Figure PQRS before drawing.

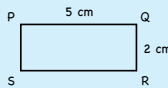

- Step 1** Draw a straight line measuring 5 cm. Label the line SR.

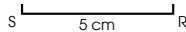

- Step 2** Use a protractor to measure 90° from point S. Mark this point with a dot. Repeat this for point R.



Textbook 4 P141

For Let's Learn 3, a protractor is used instead of set squares. Repeat the same process as Let's Learn 2.

Step 3 Place a ruler along the dot and point S. Draw a straight line to join point S and the dot. Repeat for point R.

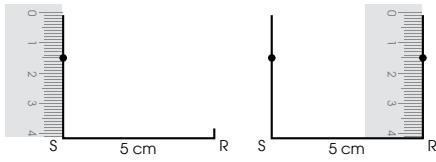

Step 4 Place a ruler along the line joining the dot and point S. Measure and mark out 2 cm on the line. Repeat for the line joining the dot and point R. Label the points P and Q.

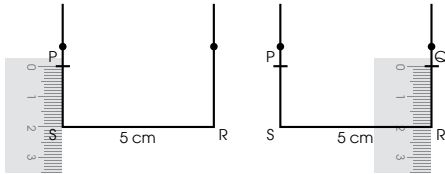

Step 5 Use a ruler to join P and Q. Complete your drawing by labelling the figure.

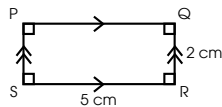

OXFORD
UNIVERSITY PRESS

SQUARES AND RECTANGLES

142

Textbook 4 P142

Remind pupils to complete the drawing by labeling Figure PQRS. Then get pupils to check their drawing against the sketch.

3. How do we change the orientation of the rectangle shown?



We change its orientation by rotating it.

'Rotate' means to turn.

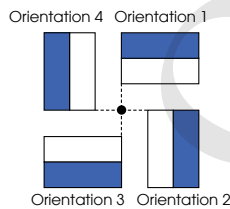

Rotate the rectangle 90° clockwise.

The rectangle changes from Orientation 1 to Orientation 2.

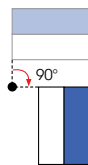

What does clockwise mean?

143 CHAPTER 7

OXFORD
UNIVERSITY PRESS

Textbook 4 P143

Review the concept of turns which they learnt in Chapter 5.

After each rotation, get pupils to describe how it has changed from the original position (e.g. the horizontal lines become vertical lines and vice versa).

Rotate the rectangle 180° clockwise.
The rectangle changes from Orientation 1 to Orientation 3.

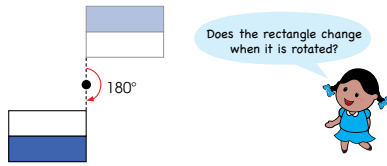

Rotate the rectangle 270° clockwise.
The rectangle changes from Orientation 1 to Orientation 4.

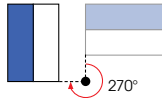

Rotate the rectangle 360° clockwise.
The orientation of the rectangle does not change.

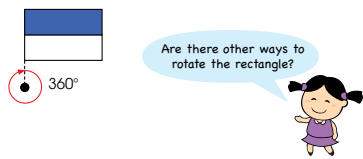

Textbook 4 P144

Lead pupils to see that the rectangle remained unchanged when rotated 360° .

Repeat the process in the anticlockwise direction.

Work in pairs.

- 1 Shuffle separately.
- 2 Pick a card from each deck.
- 3 Draw the picture you see on .
- 4 Read the instructions on the and record it.
- 5 Rotate according to the instructions.

Draw the picture on after rotating.

Before rotation	Instructions	After rotation
	Turn 90° clockwise	

- 6 Take turns and repeat 2 to 5.

ACTIVITY TIME

What you need:



Assign pupils to work in pairs. Distribute a set of play cards (refer to the templates in Activity Handbook 4 P34 – 35) to each pair. The activity enhances pupils' ability to visualise in a fun way.

Textbook 4 P145



1. Copy the following onto a 1-cm square grid paper.
Complete Rectangle ABCD and Square EFGH.

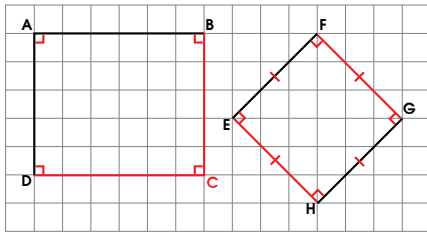

2. Draw the following figures.
(a) 4 cm by 4 cm square
(b) 3 cm by 7 cm rectangle

Complete Workbook 4A, Worksheet 2 • Pages 135 – 137



MIND WORKOUT

How many squares can you see in the figure? 16 squares

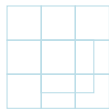

Distribute square grid papers to pupils to do the practice questions. Allow pupils to work on the questions individually. Move around the class to monitor individual pupils' drawing.

Independent seatwork

Assign pupils to complete Worksheet 2 (Workbook 4A P135 – 137).

1. (a)

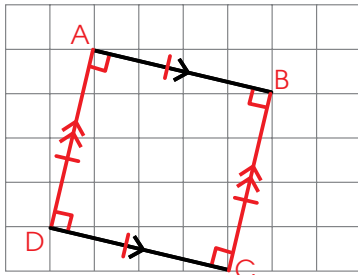

Figure ABCD

(b)

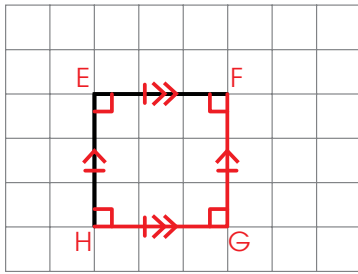

Figure EFGH

2. (a)

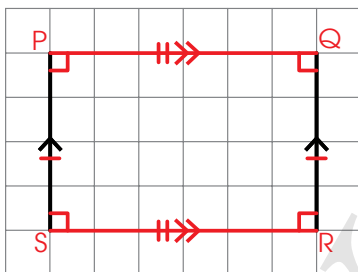

Figure PQRS

(b)

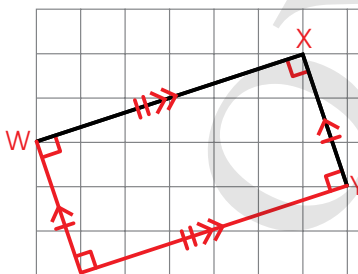
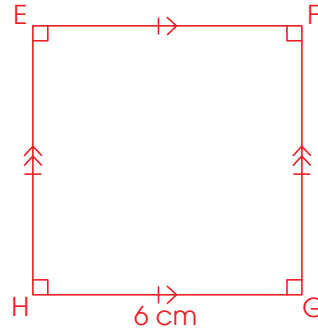
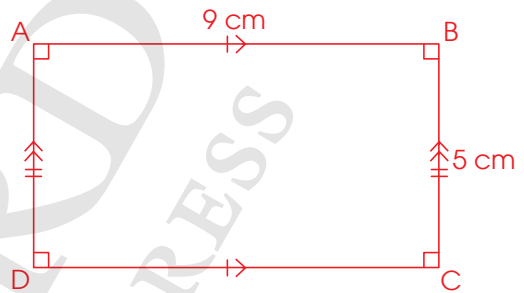

Figure WXYZ

3.



4.



5.

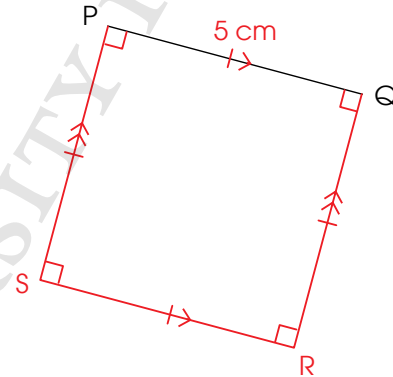

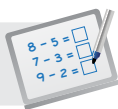
**Specific Learning Focus**

- Draw rectangles and squares on square grid paper and according to a given dimension using protractors, ruler and set squares.
- Observe the different orientations of a rectangle when it is rotated.

Suggested Duration

2 periods

Prior Learning

Pupils should be aware of how to draw perpendicular and parallel lines. They should be well-versed with the properties of a square and a rectangle.

Pre-emptive Pitfalls

When drawing squares and rectangles, pupils have to ensure that the properties are met. Emphasise to pupils that they need to use protractor, ruler and set square to draw. It is advisable to recap with pupils the steps to drawing parallel and perpendicular lines.

Introduction

Guide pupils to draw a square and a rectangle respectively by giving instructions and drawing on the board. At the same time, ask pupils to draw the shapes as well.

Problem Solving

In Let's Learn 3 (Textbook 4 P143 – 144), the change in orientation of the rectangle, while the shape remains unchanged, is explained. It involves the rotation of a two-dimensional shape about a point and at 1, 2 or 3 right-angle turns (90° , 180° , 270°). This example deals with the concept of rotation and change in orientation of a rectangle or a square.

Activities

For 'Activity Time' (Textbook 4 P145), get pupils to work in pairs. Provide each pair with a set of play cards.

Resources

- play cards (Activity Handbook 4 P34 – 35)
- square grid paper (Activity Handbook 4 P24)
- set squares
- protractor
- ruler

Mathematical Communication Support

While drawing the shapes, ask pupils the following questions to prompt for mathematical reasoning:

- What should we use to measure the angles and draw the shapes?
- Why do we measure the same length for the sides?
- Are all four sides of a rectangle equal in length?

PROBLEM SOLVING, MATHS JOURNAL AND PUPIL REVIEW

PRACTICE

- Copy the following onto a 1-cm square grid paper.
Complete Rectangle ABCD and Square EFGH.

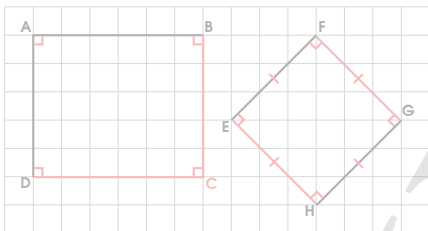

- Draw the following figures.
(a) 4 cm by 4 cm square
(b) 3 cm by 7 cm rectangle

Complete Workbook 4A, Worksheet 2 • Pages 135 – 137



MIND WORKOUT

How many squares can you see in the figure? **16 squares**

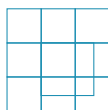

OXFORD
UNIVERSITY PRESS

SQUARES AND RECTANGLES

146



MIND WORKOUT

The activity challenges pupils' spatial visual ability.
Teacher may guide pupils by making a systematic list.

Textbook 4 P146



Mind Workout

Date: _____

Form a rectangle using all the squares given.
Cut and paste the squares in the space given below.

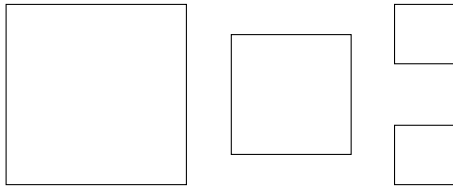
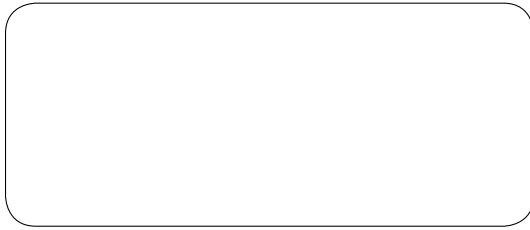

138 Chapter 7

OXFORD UNIVERSITY PRESS

Workbook 4A P138



Mind Workout

Accept all answers that are correct.

MATHS JOURNAL

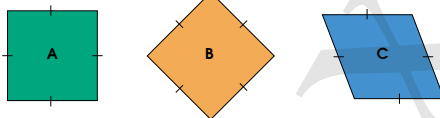

Figures A, B and C each have sides of equal length.
Figure A is a square.
Are Figures B and C squares?
Explain your answers.

I know how to...

- describe the properties of squares.
- describe the properties of rectangles.
- draw squares and rectangles.

SELF-CHECK



147 CHAPTER 7

OXFORD UNIVERSITY PRESS

Textbook 4 P147

MATHS JOURNAL

Have the properties of square displayed visibly for pupils' reference and remind pupils to use mathematical properties when providing reasoning.

If necessary, teacher may prepare partially completed sentences to facilitate pupils' reasoning.

Example:

- It has ___ equal sides.
- Its angles are _____.
- Figure A is a _____.

SELF-CHECK



Before the pupils do the self-check, review the important concepts once more by asking for examples learnt for each objective.

This self-check can be done after pupils have completed **Review 7** (Workbook 4A P139 – 142).

1. (a) A square has **4** equal sides.

$$AB = BC = CD = DA$$

(b) The opposite sides of a square are parallel.

$$BC \parallel AD$$

$$AB \parallel CD$$

(c) A square has **4** angles.

All its angles are equal to **4**°.

$$\angle DAB = \angle ABC = \angle BCD = \angle CDA = 90^\circ$$

6.

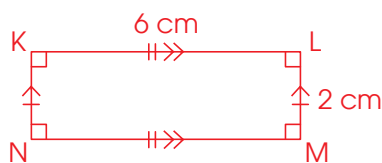

2. (a) A rectangle has **4** sides.

(b) Its opposite sides are of the same length.

$$PS = QR$$

$$PQ = SR$$

(c) The opposite sides of a rectangle are parallel.

$$PQ \parallel SR$$

$$PS \parallel QR$$

(d) A rectangle has **4** angles.

All its angles are equal to **90**°.

$$\angle SPQ = \angle PQR = \angle QRS = \angle RSP = 90^\circ$$

3. (a) 65

(b) 53

4.

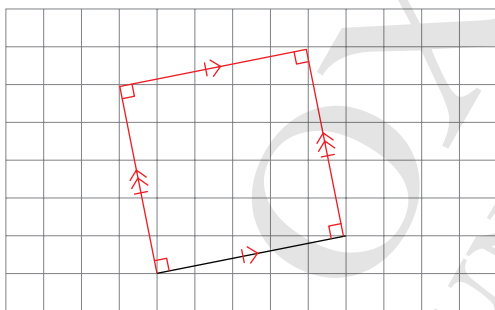

5.

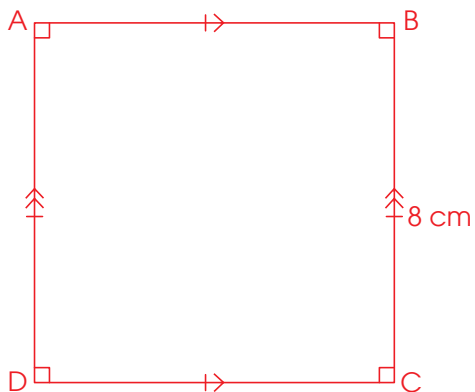

1. (a)

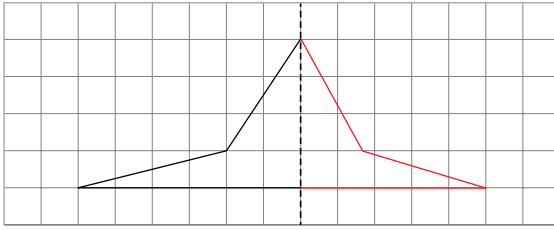

(b)

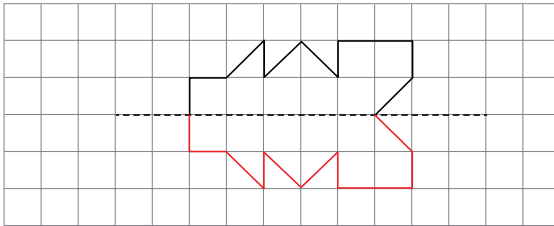

(c)

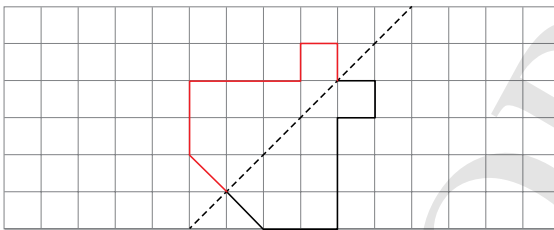

2.

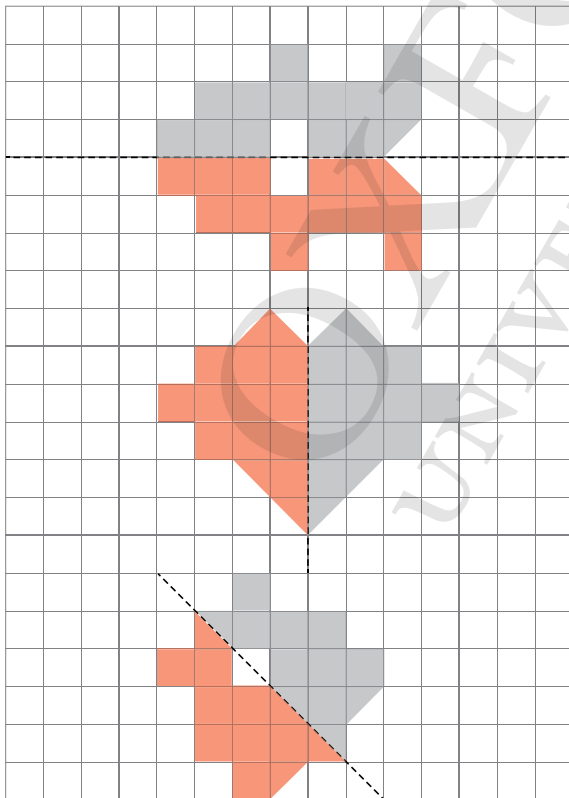

3. (a) 105°
(b) 48°

4. (a)

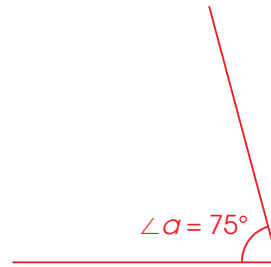

(b)

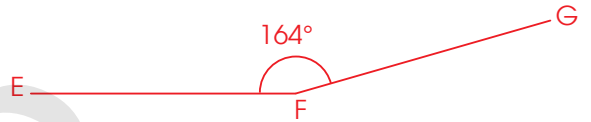

6. (a) $\frac{1}{2}$ of a complete turn is 180° .

(b) $\frac{1}{4}$ of a complete turn is 90° .

7. (a) southwest
(b) northeast
(c) playground
(d) petrol station

8.

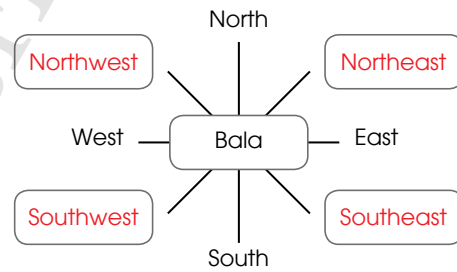

- (a) east
(b) east
(c) southeast
(d) east
(e) southwest

9. (a) west
(b) C
(c) northeast
(d) B

1. 17

- 2. (a) BC
- (b) BC
- (c) DC
- (d) 16

- 3. (a) FG
- (b) FE
- (c) HG
- (d) FG, EH
- (e) 4, rectangle

4. 42

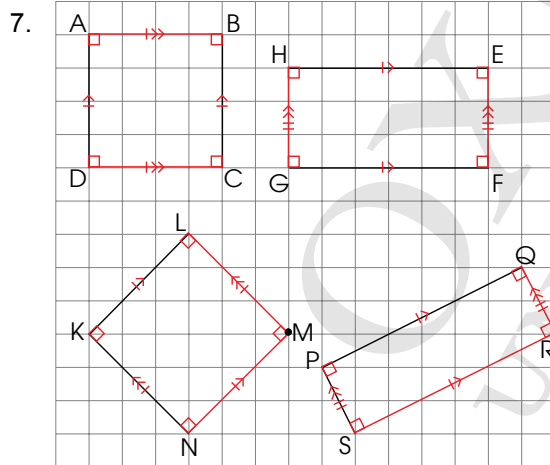
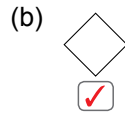
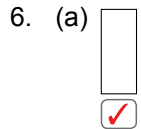
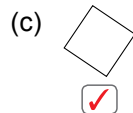
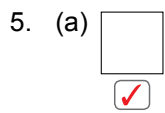

- (a) square
- (b) rectangle
- (c) square
- (d) rectangle

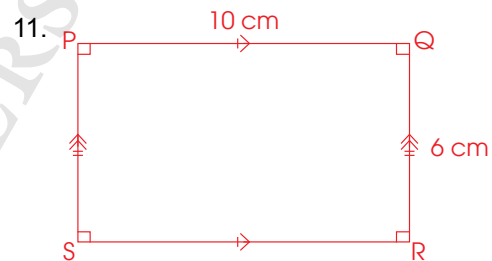
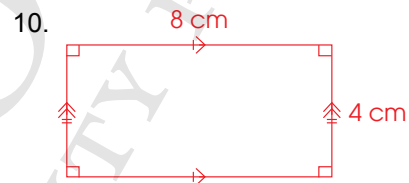
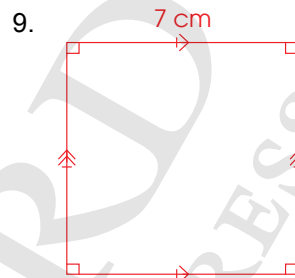
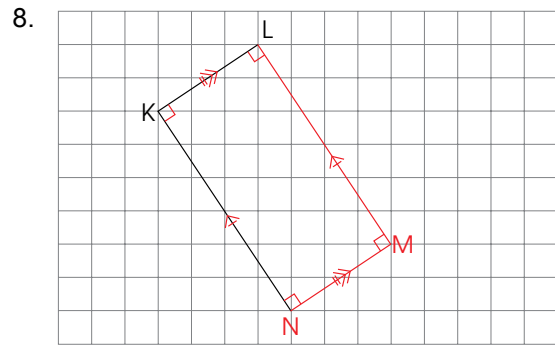

1. 3

2. 2

3. 4

4. 4

5. 4

6. 1

7. 4

8. 3

9. 3

10. 1

11. Twelve thousand, seven hundred and thirty-eight

12. 20 357

13. 24 000

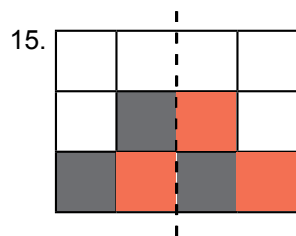
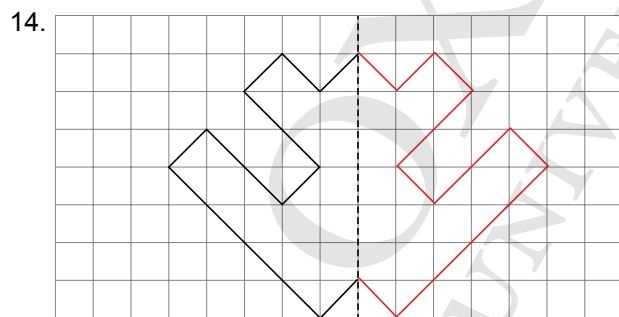

16. 17 472

17. 118

18. \$1373

19. 150

20. $1\frac{7}{10}$ km

21. $\frac{5}{6}$ hr

22. $2\frac{7}{10}$ m

23. 104°
 103° and 105° can be accepted

24. 115°
 114° and 116° can be accepted

25.

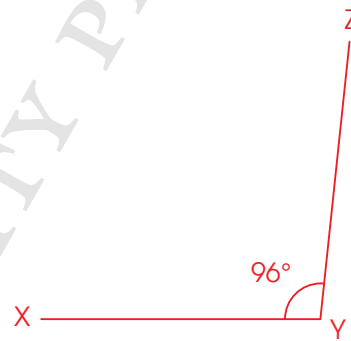

26. Raju

27. 180°

28. southwest

29. Weiming

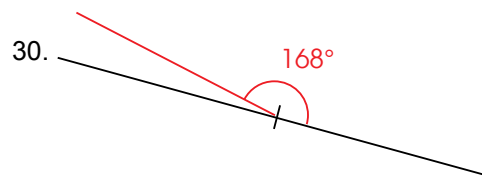

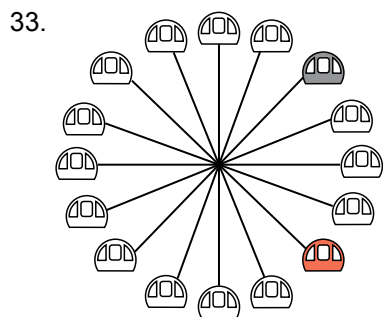
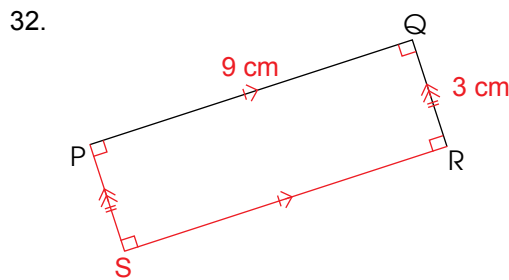
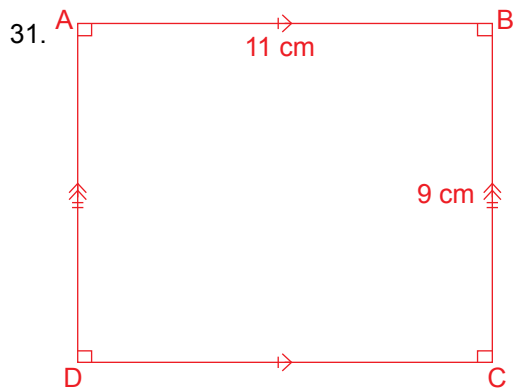

34. 2

Jan	Feb	Mar	Apr	May	Jun
x		x		x	
x			x		

Jul	Aug	Sep	Oct	Nov	Dec
x		x		x	
x			x		

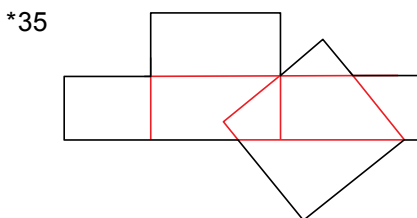

36. $150 \div 3 = 50$
There were 50 children.

37. $1 - \frac{3}{5} = \frac{2}{5}$
 $120 \div 5 = 24$
 $24 \times 2 = 48$
There were 48 angkana trees.

38. $1 \ell - \frac{1}{5} \ell = \frac{4}{5} \ell$
 $\frac{4}{5} \ell - \frac{1}{2} \ell = \frac{3}{10} \ell$
She drank $\frac{3}{10} \ell$ of lemonade.

39. $\frac{3}{8} \text{ kg} - \frac{1}{4} \text{ kg} = \frac{5}{8} \text{ kg}$
 $3 \text{ kg} - \frac{5}{8} \text{ kg} = 2\frac{3}{8} \text{ kg}$
She had $2\frac{3}{8} \text{ kg}$ of sugar left.

40. $1 - \frac{3}{4} = \frac{1}{4}$
 $200 \div 4 = 50$
Bala had 50 marbles left.

41. $\$2580 - \$400 = \$2180$
 $\$2180 \div 2 = \1090
Ahmad saved \$1090.

42. $728 + 462 = 1190$
 $1190 \div 2 = 595$
 $728 - 595 = 133$
Nora must give Xinyi 133 stickers.

43. $1836 \div 6 = 306$
 $306 \times 26 = 7956$
The answer is 7956.

44. $\$263 \times 7 = \1841
 $\$4937 - \$1841 = \$3096$
 $\$3096 \div 2 = \1548
Each bed frame cost \$1548.

45. $1 \text{ kg L} = 2 \text{ kg C}$
 $2 \text{ kg L} = 4 \text{ kg C}$
 $9 \text{ kg C} = \$126$
 $1 \text{ kg C} = \$126 \div 9$
 $= \$14$
 $124 \text{ kg C} = \$14 \times 124$
 $= \$1736$
The total cost of 124 kg of crabs is \$1736.

DECIMALS (I)

CHAPTER

8

Decimals (I) CHAPTER **8**

What are some examples of decimals around you?

TENTHS LESSON **1**

IN FOCUS

Look at the shaded parts in each figure.
1 whole

?

How do we express 1 part out of 10 parts as a decimal?

OXFORD UNIVERSITY PRESS DECIMALS (I) 148

Textbook 4 P148

Related Resources

NSPM Textbook 4 (P148 – 185)

NSPM Workbook 4B (P1 – 32)

Materials

Number and decimal discs, place-value chart, dice, numeral cards, ruler, measuring tapes, 1-ℓ beaker

Lesson

Lesson 1 Tenths

Lesson 2 Hundredths

Lesson 3 Thousandths

Lesson 4 Comparing and Ordering Decimals

Lesson 5 Rounding Decimals

Lesson 6 Fractions and Decimals

Problem Solving, Maths Journal and Pupil Review

INTRODUCTION

Decimal is introduced in Grade Four as an extension of the concept of whole numbers. The decimal notations for tenths, hundredths and thousandths are linked to the concepts of fraction. For a more meaningful understanding, real-life examples like prices, length, mass and volume using decimals are illustrated. The learning experiences reinforce pupils' concept of decimals by getting pupils to measure the height of their groupmates and things around them. The skill of rounding which pupils learnt in Chapter 1 (Number to 100 000) is expanded to include rounding decimals to the nearest whole number, 1 decimal place and 2 decimal places.

LESSON

1

TENTHS

LEARNING OBJECTIVES

1. Read and write 1-place decimals.
2. Interpret 1-place decimals in terms of place value.

Decimals (I)
CHAPTER 8

TENTHS

IN FOCUS

Look at the shaded parts in each figure.

1 whole

?

How do we express 1 part out of 10 parts as a decimal?

LESSON

1

OXFORD UNIVERSITY PRESS

DECIMALS (I) **148**

IN FOCUS

Using Chapter Opener, discuss the use of decimals in real-life context. Ask:

- What is the volume of the paint?
- How much is the paint brush?

Write pupils' answers on the board and ask what they notice about the numbers. Ask Pupils:

- Are they whole numbers?

Display a whole strip of paper and tell pupils that it represents one whole. Then fold it into 10 equal parts and ask pupils how 1 out of 10 equal parts can be expressed as a decimal.

Textbook 4 P148

LET'S LEARN

1. Divide 1 whole into 10 equal parts.

1 part out of 10 parts is $\frac{1}{10}$.

$$\frac{1}{10} = 1 \text{ tenth} \\ = 0.1$$

$\frac{1}{10}$ is 0.1 when written as a decimal.

We read 0.1 as **zero point one**.

The dot in a decimal is called the **decimal point**.



2. How many parts of each figure are shaded? Express as fractions and decimals.



$$\frac{5}{10} = 0.5$$



$$\frac{7}{10} = 0.7$$

3. Express $3\frac{2}{10}$ as a decimal.

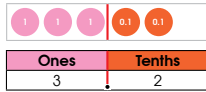

$$3\frac{2}{10} = 3 \text{ ones} + 2 \text{ tenths} \\ = 3 + 0.2 \\ = 3.2$$

The digit 3 is in the ones place. The digit 2 stands for 0.2.

We read 3.2 as **three point two**.



Textbook 4 P149

LET'S LEARN

In Let's Learn 1, introduce the term **1 tenth** and the decimal notation **0.1**. Draw pupils' attention to the decimal point and how to read the decimal. Teacher can shade more parts and continue the drill with 0.2, 0.3, and so on.

Use Let's Learn 2 to reinforce the concepts learnt in Let's Learn 1. Lead pupils to see that the 1 whole has been divided into 10 equal parts.

For Let's Learn 3, use number and decimal discs to represent the decimal on the place-value chart and guide pupils to see the link between decimals and whole numbers: that a decimal is made up of a whole number

part and a fraction part. Introduce the **0.1** and its place value. Draw pupils' attention to the red line on the place-value chart that denotes the decimal point

4. Express each of the following as a decimal.

Use and to help you.

(a) $1\frac{6}{10}$ 1.6 (b) $2\frac{4}{10}$ 2.4

(c) $4\frac{8}{10}$ 4.8 (d) $10\frac{1}{10}$ 10.1

5. 1 tenth of this figure is shaded.



10 tenths of this figure are shaded. What is 10 tenths?



$$10 \text{ tenths} = \frac{10}{10} \\ = 1.0$$

$$10 \text{ tenths} = 1 \text{ one}$$

We can also use and to exchange 10 tenths for 1 one.

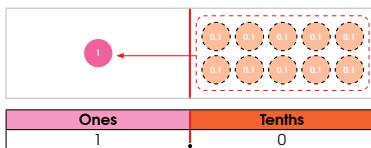

Textbook 4 P150

Allow pupils to work in pairs for Let's Learn 4. Pupils will practice using number and decimal discs to represent the mixed numbers and express them as decimals.

Using the fraction strip in Let's Learn 5, guide pupils to see that 10 tenths is equal to 1 one.

Get pupils to count the tenth discs aloud (0.1, 0.2...). Guide pupils to see that 10 tenths is equivalent to 1 one by replacing the ten tenths discs with a ones disc.

6. Express $\frac{12}{10}$ as a decimal.

Use  and  to show the decimal.

Exchange 10 tenths for 1 one.

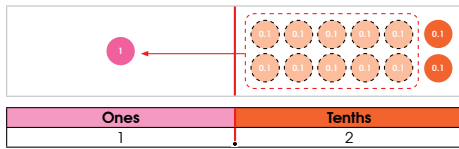

$$\begin{aligned} \frac{12}{10} &= 12 \text{ tenths} \\ &= 10 \text{ tenths} + 2 \text{ tenths} \\ &= 1 \text{ one} + 2 \text{ tenths} \\ &= 1.2 \end{aligned}$$

7. Express each of the following as a decimal.

Use  and  to help you.

- (a) $\frac{15}{10}$ 1.5 (b) $\frac{22}{10}$ 2.2
 (c) $\frac{30}{10}$ 3.0 (d) $\frac{65}{10}$ 6.5

8. What is the decimal represented by each letter?

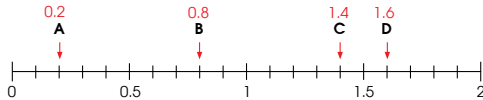

Textbook 4 P151

Allow pupils to work in pairs for Let's Learn 6. Pupils will represent the improper fraction as tenths and perform the renaming on the place-value chart.

Pupils will continue to work on similar examples in Let's Learn 7.

Using Let's Learn 8, tell pupils that decimals are like fractions and can be represented on the number line. Project the number line on the screen and ask pupils for the equivalent of 0.5, 1, 1.5 and 2 in mixed numbers/improper fractions. Get pupils to identify the decimals represented by the letters.

9.



What is the length of the screw?

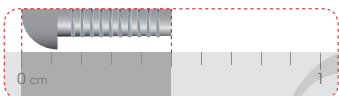

Let us take a closer look at the ruler.

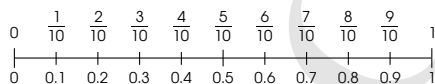

$$\begin{aligned} \frac{5}{10} &= 5 \text{ tenths} \\ &= 0.5 \end{aligned}$$

The screw is 0.5 cm long.

10. Express each measurement as a fraction and a decimal.

(a)



The length of the nail is $\frac{4}{10}$ cm or 0.4 cm.

(b)



The volume of the water shown is $\frac{8}{10}$ ℓ or 0.8 ℓ.

Textbook 4 P152

For Let's Learn 9, first focus on the 1-cm marking then guide pupils to see that 1 cm is divided into 10 equal parts. Next, help pupils relate the reading on the ruler to the number line.

Let's Learn 10 gives more real-life examples of measurements in decimal. Guide pupils to read the scales on each measuring tool and write them in fractions and in decimals.

(c)

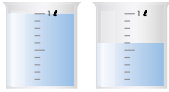

The total volume of

water is $1\frac{6}{10}$ l or 1.6 l.

(d)



The mass of the fish is

$2\frac{3}{10}$ kg or 2.3 kg.

11. What is the value of each digit in 25.9?

Tens	Ones	Tenths
2	5	9

25.9 = 2 tens 5 ones 9 tenths

$$= 20 + 5 + \frac{9}{10}$$

$$= 20 + 5 + 0.9$$

The digit 2 is in the tens place.

The digit 5 stands for 5.

The value of the digit 9 is 0.9.

12. What is the value of 4 in each of the following?

- (a) 94.7 4 (b) 43.9 40
 (c) 15.4 0.4 (d) 456.8 400

Textbook 4 P153

Let's Learn 10 aims to help pupils recognise the usage of decimals in real-life. Allow pupils to discuss and give other examples of decimals they have encountered.

Use number and decimal discs and the place-value chart to represent the 1-place decimal in Let's Learn 11. Then work with pupils to fill in the blanks by writing the decimal in expanded form of tens, ones and tenths.

Get pupils to work in pairs for Let's Learn 12. Remind pupils to write each number in expanded form and then answer the question.

ACTIVITY TIME

Work in pairs.

- Throw the dice twice to obtain two numbers.
- Use the numbers to form a decimal.
- Get your partner to use number and decimal discs to represent the decimal.
- Write an equation as shown below.

What you need:



Example

$$4.6 = 4 \text{ ones } 6 \text{ tenths} \\ = 4 + 0.6$$

- Take turns and repeat 1 to 4.

PRACTICE

1. How many parts of each figure are shaded? Express your answer as a decimal.

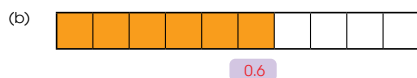

2. Express each of the following as a decimal.

(a) $7\frac{7}{10}$ 7.7

(b) $15\frac{8}{10}$ 15.8

(c) $\frac{14}{10}$ 1.4

(d) $\frac{37}{10}$ 3.7

Textbook 4 P154

ACTIVITY TIME

This activity allows pupils to form 1-place decimals, represent them with number and decimal discs and write them in expanded form. Pupils can check each others' answers.

PRACTICE

Work with pupils on the practice questions.

For better understanding, select items from **Worksheet 1** and work these out with the pupils.

3. Express each measurement as a fraction and a decimal.

(a)



The books weigh $\frac{7}{10}$ kg
or 0.7 kg.

(b)

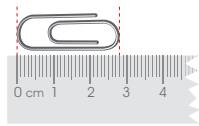

The length of the paper clip
is $2\frac{8}{10}$ or 2.8 cm.

4. What is the value of each digit?

Tens	Ones	Tenths
3	9	4

$$39.4 = 3 \text{ tens } 9 \text{ ones } 4 \text{ tenths} \\ = 30 + 9 + 0.4$$

The value of the digit 3 is 30.

The value of the digit 9 is 9.

The value of the digit 4 is 0.4.

Complete Workbook 4B, Worksheet 1 • Pages 1 – 6

Independent seatwork

Assign pupils to complete Worksheet 1 (Workbook 4B P1 – 6).

1. (a) $\frac{3}{10} = 0.3$

(b) $\frac{6}{10} = 0.6$

(c) $\frac{8}{10} = 0.8$

2. (a) 3.5

(b) 8.6

(c) 40.9

(d) 65.3

3. (a) 2.4

(b) 4.8

(c) 5.3

(d) 7.0

4. (a)

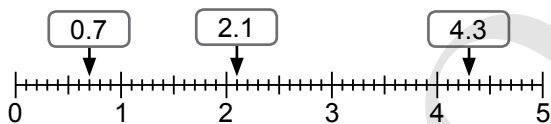

(b)

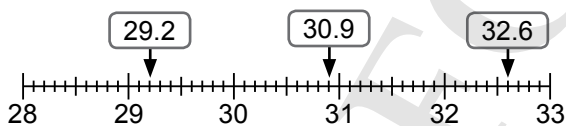

(c)

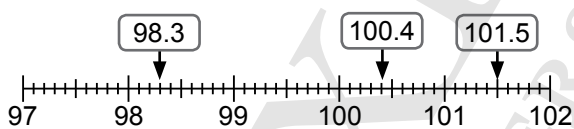

5. (a) $\frac{7}{10}$ cm = 0.7 cm

(b) $3\frac{2}{10}$ cm = 3.2 cm

(c) $\frac{7}{10}$ kg = 0.7 kg

(d) $2\frac{3}{10}$ kg = 2.3 kg

(e) $\frac{3}{10}$ ℓ = 0.3 ℓ

(f) $1\frac{5}{10}$ ℓ = 1.5 ℓ

6. (a) 0.7

(b) 0.9

(c) 5.0

(d) 3.1

7. (a) 6.2 = 6 ones 2 tenths
= 6 + 0.2

(b) 7.3 = 7 ones 3 tenths
= 7 + 0.3

8. (a) 3

(b) 0.9

(c) 3, 0.3

(d) tenths

LESSON 2

HUNDREDTHS

LEARNING OBJECTIVES

1. Read and write 2-place decimals.
2. Interpret 2-place decimals in terms of place values.

HUNDREDTHS

LESSON
2

IN FOCUS

Look at the shaded parts in each figure.

1 whole



1 tenth

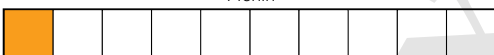

We get 100 parts when we divide each tenth into 10 parts.

?

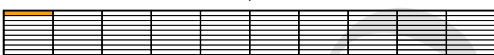

How do we express 1 part out of 100 parts as a decimal?

LET'S LEARN

1. Divide 1 whole into 100 equal parts.

1 part out of 100 parts is $\frac{1}{100}$.

$\frac{1}{100} = 1$ hundredth
 $= 0.01$

$\frac{1}{100}$ is **0.01** when written as a decimal.



We read 0.01 as
zero point zero one.

OXFORD UNIVERSITY PRESS
DECIMALS (1)
156

Textbook 4 P156

IN FOCUS

With the aid of a visualiser, point to the first bar and tell pupils that it represents 1 whole. Ask pupils:

- If we divide 1 whole into 10 equal parts, what do we call each part?
- If we divide each tenth into 10 equal parts, how many parts will there be in 1 whole and how do we express 1 out of 100 parts as a decimal?

LET'S LEARN

Using Let's Learn 1, introduce the term **1 hundredth** and the decimal notation **0.01**. Get pupils to read 0.01. Continue to shade more hundredths and repeat the drill.

2. What is the decimal represented by each figure?

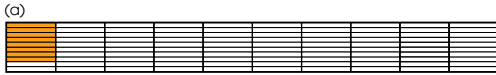

$$\frac{8}{100} = 8 \text{ hundredths}$$

$$= 0.08$$



$$\frac{3}{100} = 0.03$$

3. Express 10 hundredths as a decimal.



$$10 \text{ hundredths} = \frac{10}{100}$$

$$= \frac{1}{10}$$

$$= 0.1$$

10 hundredths = 1 tenth

Exchange 10 hundredths for 1 tenth.

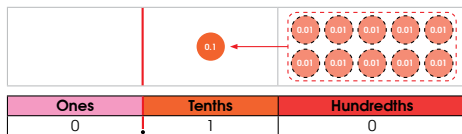

157

CHAPTER 8

OXFORD
UNIVERSITY PRESS

Textbook 4 P157

Use Let's Learn 2 to reinforce the concept taught in Let's Learn 1, emphasising that 1 whole is divided into 100 equal parts.

Let's Learn 3 helps pupils recognise the equivalence between 10 hundredths and 1 tenth through fraction and place-value concepts. Using the model here, guide pupils to see that 10 hundredths equal 1 tenth.

Next using decimal discs, guide pupils to see that 10 hundredths equals 1 tenths by replacing 10 pieces

of **0.01** with a **0.1**.

4. Express $\frac{15}{100}$ as a decimal.

Use to show the decimal.

Count on in hundredths with .



Exchange 10 hundredths for 1 tenth.

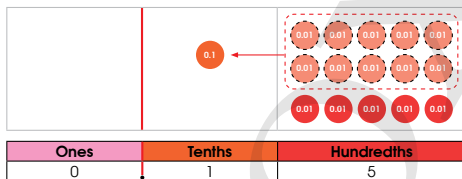

$$\frac{15}{100} = 15 \text{ hundredths}$$

$$= 10 \text{ hundredths} + 5 \text{ hundredths}$$

$$= 1 \text{ tenth} + 5 \text{ hundredths}$$

$$= 0.1 + 0.05$$

$$= 0.15$$

The digit 1 is in the tenths place.

The value of the digit 5 is 0.05.

5. Express each of the following as a decimal.

(a) 46 hundredths **0.46**

(b) 68 hundredths **0.68** help you.

(c) $\frac{16}{100}$ **0.16**

(d) $\frac{99}{100}$ **0.99**



OXFORD
UNIVERSITY PRESS

DECIMALS (1)

158

Textbook 4 P158

For Let's Learn 4, use decimal discs and a place-value chart to represent the 2-place decimal. Demonstrate the renaming process and guide pupils to write the decimal in the expanded form of tenths and hundredths.

For Let's Learn 5, allow pupils to work in pairs using decimal discs to represent each given number and express it as a 2-place decimal.

6. Express $1\frac{35}{100}$ as a decimal.

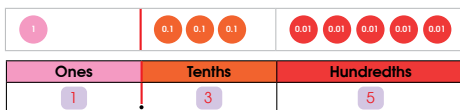

$$\begin{aligned}
 1\frac{35}{100} &= 1 \text{ one} + 3 \text{ tenths} + 5 \text{ hundredths} \\
 &= 1 + 0.3 + 0.05 \\
 &= 1.35
 \end{aligned}$$

7. Express each mixed number as a decimal.

Use and to help you.

- (a) $5\frac{5}{100}$ 5.05 (b) $2\frac{23}{100}$ 2.23
 (c) $4\frac{35}{100}$ 4.35 (d) $6\frac{30}{100}$ 6.3

8. Express $1\frac{24}{100}$ as a decimal.

$$\begin{aligned}
 1\frac{24}{100} &= 124 \text{ hundredths} \\
 &= 100 \text{ hundredths} + 24 \text{ hundredths} \\
 &= 1 \text{ one} + 24 \text{ hundredths} \\
 &= 1 + \frac{24}{100} \\
 &= 1 + 0.24 \\
 &= 1.24
 \end{aligned}$$

100 hundredths = $\frac{100}{100}$
= 1 one



Textbook 4 P159

Using Let's Learn 6, show pupils how to express a mixed number with denominator of 100 as a 2-place decimal. Illustrate with number discs and the place-value chart the expanded form of the decimal.

Allow pupils to work in pairs for Let's Learn 7. Pupils can use number and decimal discs to help them express the mixed numbers as decimals.

For Let's Learn 8, show pupils how to express an improper fraction with denominator of 100 as a decimal.

9. Express each improper fraction as a decimal.

Use and to help you.

- (a) $\frac{113}{100}$ 1.13 (b) $\frac{316}{100}$ 3.16
 (c) $\frac{302}{100}$ 3.02 (d) $\frac{260}{100}$ 2.6

10. What are the missing decimals?

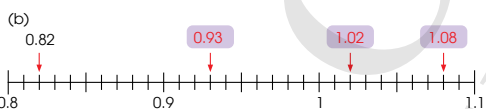
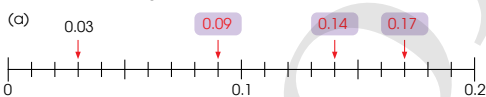

11. What is the value of each digit in 31.58?

Tens	Ones	Tenths	Hundredths
3	1	5	8

$$\begin{aligned}
 31.58 &= 3 \text{ tens} + 1 \text{ one} + 5 \text{ tenths} + 8 \text{ hundredths} \\
 &= 30 + 1 + \frac{5}{10} + \frac{8}{100} \\
 &= 30 + 1 + 0.5 + 0.08
 \end{aligned}$$

The value of the digit 3 is 30.

The digit 1 is in the ones place.

The digit 5 stands for 0.5.

The value of the digit 8 is 0.08.

Textbook 4 P160

Pupils will work on similar examples in Let's Learn 9 using number and decimal discs.

In Let's Learn 10(a), guide pupils to recognise the markings between 0 and 0.1 as 0.01, 0.02, 0.03, ... Continue counting along the number line to identify the missing decimals.

Repeat the same process for Let's Learn 10(b).

Guide pupils to fill in the blanks in Let's Learn 11 and assess their understanding of the place value of a 2-place decimal.

12. What is the value of the digit 3 in each of the following?

- (a) 23.12 **3** (b) 312.48 **300**
 (c) 61.35 **0.3** (d) 10.03 **0.03**

ACTIVITY TIME

Work in groups of 4.

- 1 Take turns to measure the height of each group member.

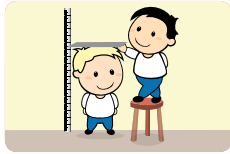

What you need:

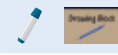

- 2 Record the name and the height of each group member. Write the height in metres as a decimal and as a mixed number.

Name	Height as a decimal	Height as a mixed number
Tom	1.34 m	$1\frac{34}{100}$ m

You can also try out this activity by measuring and recording the weight of your group members.



Textbook 4 P161

Allow pupils to work in pairs for Let's Learn 12 before going through the answers.

ACTIVITY TIME

The activity allows pupils to record decimals in real-life context when measuring their groupmates' height and taking their weight.

1. What is the decimal shown?



$$\frac{50}{100} = 50 \text{ hundredths} \\ = 0.5$$

2. Express each of the following as a decimal.

- (a) $1\frac{72}{100}$ **1.72** (b) $2\frac{98}{100}$ **2.98**
 (c) $\frac{162}{100}$ **1.62** (d) $\frac{201}{100}$ **2.01**

3. What are the missing numbers?

Tens	Ones	Tenths	Hundredths
6	5	7	8

65.78 = 6 tens 5 ones 7 tenths **8** hundredths

$$= 60 + 5 + \frac{7}{10} + \frac{8}{100} \\ = 60 + 5 + 0.7 + 0.08$$

The digit 5 is in the **ones** place.

The value of the digit 7 is **0.7**.

Complete Workbook 4B, Worksheet 2 • Pages 7 – 12

Textbook 4 P162

PRACTICE

Work with pupils on the practice questions.

For better understanding, select items from **Worksheet 2** and work these out with the pupils.

Independent seatwork

Assign pupils to complete Worksheet 2 (Workbook 4B P7 – 12).

1. (a) $\frac{5}{100} = 0.05$
 (b) $\frac{13}{100} = 0.13$
 (c) $\frac{30}{100} = 0.3$

2. (a) 2.59
 (b) 5.32
 (c) 8.7
 (d) 10.04

3. (a) 1.59
 (b) 2.45
 (c) 3.02
 (d) 9.3

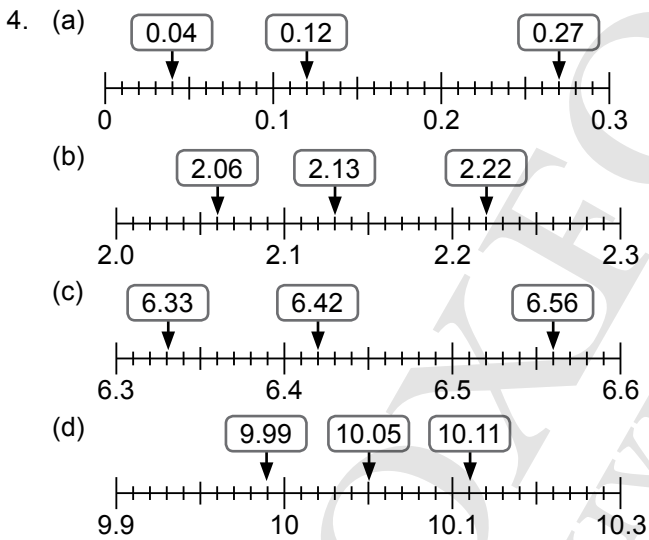

5. (a) 0.05
 (b) 0.37
 (c) 2.72
 (d) 4.07
 (e) 2.65
 (f) 3.6

6. (a) 0.02, 6, 0.3, 0.02
 (b) $24.08 = 2 \text{ tens } 4 \text{ ones } 0 \text{ tenths } 8 \text{ hundredths}$
 $= 20 + 4 + \frac{8}{100}$
 $= 20 + 4 + 0.08$

The value of the digit 2 is 20.

The value of the digit 4 is 4.

The digit 0 is in the tenths place.

The digit 8 is in the hundredths place.

7. (a) 1
 (b) 2
 (c) 0.7
 (d) 0.05

LEARNING OBJECTIVES

1. Read and write 3-place decimals.
2. Interpret 3-place decimals in term of place values.

THOUSANDTHS

LESSON
3



IN FOCUS

1 whole



1 tenth

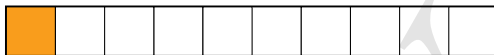

1 hundredth



We can further divide each hundredth into 10 parts to get 1000 parts.

?

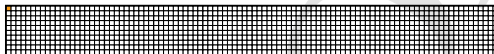

How can we express 1 part out of 1000 parts as a decimal?

LET'S LEARN

1. Divide 1 whole into 1000 equal parts.

1 part out of 1000 parts is $\frac{1}{1000}$.

$$\frac{1}{1000} = 1 \text{ thousandth} \\ = 0.001$$

$\frac{1}{1000}$ is **0.001** when written as a decimal.

We read 0.001 as
zero point zero zero one.



IN



FOCUS

Review with pupils the concepts of tenths and hundredths. Ask pupils,

- If we divide 1 hundredth into 10 equal parts, how many parts are there in 1 whole now?
- How do we express 1 out of 1000 parts as a decimal?

LET'S LEARN

Using Let's Learn 1, introduce the term **1 thousandth** and the decimal notation **0.001**. Lead the class to read 0.001.

Teacher can continue to shade more thousandths to repeat the drill.

2. Express 10 thousandths as a decimal.

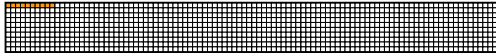

$$\begin{aligned} 10 \text{ thousandths} &= \frac{10}{1000} \\ &= \frac{1}{100} \end{aligned}$$

$$10 \text{ thousandths} = 1 \text{ hundredth}$$

Exchange 10 thousandths for 1 hundredth.

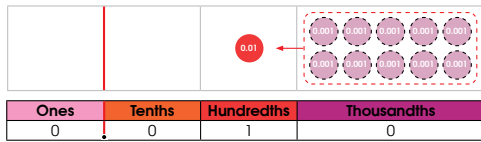

Is 0.010 the same as 0.01?



3. Express $\frac{321}{1000}$ as a decimal.



$$\begin{aligned} \frac{321}{1000} &= 321 \text{ thousandths} \\ &= 300 \text{ thousandths} + 20 \text{ thousandths} + 1 \text{ thousandth} \\ &= 3 \text{ tenths} + 2 \text{ hundredths} + 1 \text{ thousandth} \\ &= (3 \times 0.1) + (2 \times 0.01) + (1 \times 0.001) \\ &= 0.3 + 0.02 + 0.001 \\ &= 0.321 \end{aligned}$$

100 thousandths = 1 tenth



OXFORD
UNIVERSITY PRESS

DECIMALS (1) 164

Textbook 4 P164

Guide pupils to recognise the equivalence between 10 thousandths and 1 hundredth using the fraction model in Let's Learn 2.

Next introduce the 0.001 number disc. Again, guide pupils to see that 10 thousandths is equal to 1 hundredth by demonstrating the renaming process; replacing

10 pieces of 0.001 with a 0.01.

Read aloud the given fraction in Let's Learn 3 ($\frac{321}{1000}$ thousandths). Use decimal discs to represent the number in tenths, hundredths and thousandths. Demonstrate the expanded form of the given number and express it as a decimal.

4. Express each of the following as a decimal.

(a) $\frac{465}{1000} = 0.465$ (b) $\frac{708}{1000} = 0.708$

(c) $\frac{849}{1000} = 0.849$ (d) $\frac{990}{1000} = 0.990$

Use to help you.



5. Express $\frac{631}{1000}$ as a decimal.

$$\begin{aligned} \frac{631}{1000} &= 1 \text{ one} + 631 \text{ thousandths} \\ &= 1 \text{ one} + 6 \text{ tenths} + 3 \text{ hundredths} + 1 \text{ thousandth} \\ &= 1 + 0.6 + 0.03 + 0.001 \\ &= 1.631 \end{aligned}$$

Ones	Tenths	Hundredths	Thousandths
1	6	3	1

6. Express $\frac{1376}{1000}$ as a decimal.

$$\begin{aligned} \frac{1376}{1000} &= 1376 \text{ thousandths} \\ &= 1000 \text{ thousandths} + 376 \text{ thousandths} \\ &= 1 \text{ one} + 376 \text{ thousandths} \\ &= 1 + \frac{376}{1000} \\ &= 1 + 0.376 \\ &= 1.376 \end{aligned}$$

100 thousandths = $\frac{1000}{1000}$ = 1 one



Ones	Tenths	Hundredths	Thousandths
1	3	7	6

165 CHAPTER 8

OXFORD
UNIVERSITY PRESS

Textbook 4 P165

Distribute decimal discs to the pupils and allow them to work in pairs to express the fractions in Let's Learn 4 as decimals.

For Let's Learn 5, guide pupils to write the mixed number in expanded form and then express it in decimal. Relate the place value of each digit using the place-value chart.

Get pupils to read the improper fraction in Let's Learn 6 (1376 thousandths). Guide pupils to rename 1000 thousandths as 1 one. Demonstrate the steps of expressing the improper fraction as a decimal. Relate the place value of each digit using the place-value chart.

7. Express each of the following as a decimal.

(a) $9\frac{608}{1000}$ 9.608

(b) $24\frac{250}{1000}$ 24.25

(c) $\frac{2465}{1000}$ 2.465

(d) $\frac{3004}{1000}$ 3.004

Use  and  to help you.



8. What are the missing decimals?

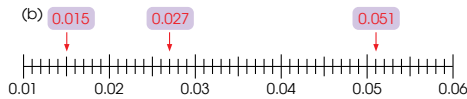
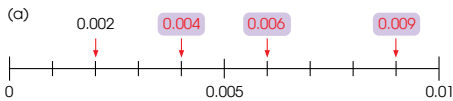

9. What is the value of each digit in 4.283?

Ones	Tenths	Hundredths	Thousandths
4	2	8	3

4.283 = 4 ones 2 tenths 8 hundredths 3 thousandths

$$= 4 + \frac{2}{10} + \frac{8}{100} + \frac{3}{1000}$$

$$= 4 + 0.2 + 0.08 + 0.003$$

The digit 4 is in the ones place.

The digit 2 stands for 0.2.

The value of the digit 8 is 0.08.

The digit 3 stands for 0.003.

OXFORD UNIVERSITY PRESS

DECIMALS (I)

166

Textbook 4 P166

For Let's Learn 7, allow pupils to work in pairs using number and decimal discs to express the mixed numbers and improper fractions as decimals.

For Let's Learn 8(a), guide pupils to recognise the markings between 0 and 0.01 are in thousandths. Lead the class to count from 0, 0.001, 0.002, 0.003, ... 0.01 and fill in the blanks.

Repeat the same process with Let's Learn 8(b).

Guide pupils to fill in the blanks in Let's Learn 9 and understand the place values of a 3-place decimal. Draw pupils' attention to the red line in the place-value chart that indicates the decimal point.

10. What are the missing numbers?

9.032

9.032 = 9 ones 0 tenths 3 hundredths 2 thousandths

$$= 9 + 0 + 0.03 + 0.002$$

The digit 9 is in the ones place.

The value of the digit 3 is 0.03.

The digit 0 is in the tenths place.

The digit 2 stands for 0.002.

ACTIVITY  TIME

Work in pairs.

1 Shuffle the .

2 Draw four cards to form a number up to the thousandths place.

3 Show different ways of representing the number.

Example

1.257 can be represented as:

(a) one tenths hundredths thousandths

(b) tenths thousandths

(c) one hundredths thousandths

(d) thousandths

4 Get your partner to check your answers.

5 Take turns and repeat 1 to 4.

What you need:



ACTIVITY  TIME

Repeat the same process for Let's Learn 10.

This activity allows pupils to form 3-place decimal with 4 digits and express the number in various combinations of ones, tenths, hundredths and thousandths. This will reinforce their understanding of the different place values of a decimal.

167

CHAPTER 8

OXFORD UNIVERSITY PRESS

Textbook 4 P167



1. Express each of the following as a decimal.

- (a) $\frac{36}{1000}$ 0.036 (b) $\frac{600}{1000}$ 0.6
 (c) $1\frac{49}{1000}$ 1.049 (d) $5\frac{522}{1000}$ 5.522
 (e) $\frac{1260}{1000}$ 1.26 (f) $\frac{3241}{1000}$ 3.241

2. What are the missing decimals?



3. What are the missing numbers?

Tens	Ones	Tenths	Hundredths	Thousandths
2	3	1	4	5

23.145 = 2 tens 3 ones 1 tenths 4 hundredths 5 thousandths

$$= 20 + 3 + \frac{1}{10} + \frac{4}{100} + \frac{5}{1000}$$

$$= 20 + 3 + 0.1 + 0.04 + 0.005$$

The value of the digit 2 is 20.

The digit 5 stands for 0.005.

The value of the digit 1 is 0.1.

Complete Workbook 4B, Worksheet 3 • Pages 13 – 16

Textbook 4 P168



Work with pupils on the practice questions.

For better understanding, select items from **Worksheet 3** and work these out with the pupils.

Independent seatwork

Assign pupils to complete Worksheet 3 (Workbook 4B P13 – 16).

Answers Worksheet 3 (Workbook 4B P13 – 16)

1. (a) 0.005
 (b) 0.463
 (c) 3.502
 (d) 20.034

2. (a) 0.028
 (b) 0.362
 (c) 3.462
 (d) 5.17

3. (a) 2.486
 (b) 3.605

4. (a) 0.009, 0.023, 0.037
 (b) 0.325, 0.341, 0.358
 (c) 4.677, 4.697, 4.706
 (d) 59.994, 60.006, 60.022

5. 7.356 = 7 ones 3 tenths 5 hundredths

$$6 \text{ thousandths}$$

$$= 7 + \frac{3}{10} + \frac{5}{100} + \frac{6}{1000}$$

$$= 7 + 0.3 + 0.05 + 0.006$$

The digit 7 is in the ones place.

The value of the digit 3 is 0.3.

The digit 5 is in the hundredths place.

The value of the digit 6 is 0.006.

6. (a) 3
 (b) 0.02
 (c) 7.813
 (d) 10.509

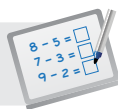

Specific Learning Focus

- Read and write 1-place decimals.
- Interpret 1-place decimals in terms of place value.

Suggested Duration

4 periods

Prior Learning

Pupils have been informally introduced to decimal points when learning money notation in Grade 2. In Grade 4, pupils are introduced to the concept of decimals in this chapter.

Pre-emptive Pitfalls

Decimals are a progression from fractions. Explain to pupils that in a decimal, the number after the decimal point represents the fraction part, whereas the number before the decimal point represents a whole number. It would be easier for pupils to understand decimals by relating to the use of decimals in real-life context (e.g. length, mass, price). They should not feel overwhelmed with another new concept to learn but should enjoy this lesson with hands-on activities using fraction bars, number and decimal discs.

Introduction

Introduce the decimal notation by pointing out that the 'dot' is the decimal point which separates the whole number from the fraction part. Explain that the first digit after the decimal point is in the tenth place, which means the digit has a fractional value with denominator 10. Help pupils understand by using the fraction bar and shade the parts to represent the decimal, and write the decimals as 0.1, 0.2, 0.3, etc. Explain that these decimals represent 1 tenth, 2 tenths, 3 tenths, etc. Show pupils that to represent a decimal on a place-value chart, we draw a red line with a dot on it to denote the decimal point and the 'tenth' column is inserted. Link mixed numbers to decimals by writing $3\frac{1}{5} \xrightarrow{\text{equivalent to}} 3\frac{2}{10} \xrightarrow{\text{equivalent to}} 3.2$, or $10\frac{1}{10} \xrightarrow{\text{equivalent to}} 10.1$.

For $10\frac{1}{10}$, verbalise the fact that when we use fraction bars to represent this mixed number, there will be one whole bar shaded and another bar divided into 10 equal parts with 1 of the 10 equal parts shaded. In Let's Learn 3 (Textbook 4 P149), use number discs, decimal discs and place-value chart to express the mixed number as a decimal. In Let's Learn 6 (Textbook 4 P151) onwards, in order to express the improper fraction as a decimal, emphasise that we must first convert the improper fraction to a mixed number. Point out that in this lesson, the denominator of the fraction is 10 as we are dealing with tenths. Number lines can also be used to represent decimals. The teacher may point out real-life examples of decimals such as the volume of water, height of a person, or length of an object, by using a ruler or measuring tape to measure.

Problem Solving

Emphasise the fact that 'deci' means one tenth and that in a 1-place decimal, the digit after the decimal point is in the tenth place. Explain to pupils that the fraction part which the number after the decimal point represents is always with a denominator of 10, 100, 1000 for a 1-place decimal, 2-place decimal and a 3-place decimal respectively, and so on. Pupils will learn hundredths and thousandths in the next two lessons.

Activities

In 'Activity Time' (Textbook 4 P154), get pupils to work in pairs and give them 5 minutes to use the number and decimal discs to represent as many decimals as they can, and write the equations for the decimals in a table. Encourage pupils to pick small objects (e.g. paper clip, stapler pin, book) in the classroom, that they think have lengths in decimals, and then measure their length using a ruler. Get them to record their measurements in a table.

Resources

- number discs (Activity Handbook 4 P5)
- decimal discs (Activity Handbook 4 P37)
- decimal bars (Activity Handbook 4 P36, 39, 42)
- place-value chart (Activity Handbook 4 P38)
- table of results (Activity Handbook 4 P41)
- number lines (Activity Handbook 4 P40, 43)
- numeral cards (Activity Handbook 4 P44)
- dice
- real-life objects
- 1-l beaker

Mathematical Communication Support

Verbalise the decimal 3.2 by saying '3 wholes and 2 tenths' or 'three point two'. Provide pupils with hands-on experience of measuring the lengths of objects in decimals and elicit individual responses to say out the lengths.

*Note to teacher:

For lessons 2 and 3, repeat the same procedure to introduce hundredths and thousandths. Experiential learning will help pupils grasp the concepts well. Use the hundredths and thousandths bars, number and decimal discs, and place-value chart to teach lessons 2 and 3.

LESSON

4

COMPARING AND ORDERING DECIMALS

LEARNING OBJECTIVE

1. Compare and order decimals.

LESSON
4

COMPARING AND ORDERING DECIMALS

IN
FOCUS

0.35 m

0.4 m

Which ribbon is longer?

LET'S LEARN

1. Compare 0.35 and 0.4.

We can also compare using the place-value chart.

Ones	Tenths	Hundredths
0	4	
0	3	5

4 tenths is greater than 3 tenths.
0.4 is greater than 0.35.
The red ribbon is longer than the blue ribbon.

169 CHAPTER 8
OXFORD UNIVERSITY PRESS

IN FOCUS

Discuss the question in In Focus. Common misconceptions:

- A number with more decimal places is greater.
- Visual misconception that blue ribbon looks longer.

LET'S LEARN

Pupils will see that the red ribbon, in Let's Learn 1, is longer. Guide pupils to compare using the place-value chart. Demonstrate the alignment of the digits according to their place values and then compare the tenths first.

Textbook 4 P169

2. Which is smaller, 2.567 or 2.57?

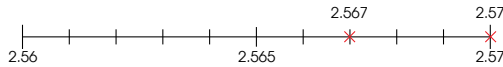

6 hundredths is smaller than 7 hundredths.
2.567 is smaller than 2.57.

3. Compare the numbers 3.6, 3.06 and 3.066. Arrange these numbers in decreasing order.

Ones	Tenths	Hundredths	Thousandths
3	6		
3	0	6	
3	0	6	6

6 tenths is greater than 0 tenths.
3.6 is the greatest.

All numbers have 3 ones.
What should we compare?

Both 3.066 and 3.06 have 6 hundredths.
What should we compare next?



Compare 3.06 and 3.066.

6 thousandths is greater than 0 thousandths.
3.066 is greater than 3.06.

3.6, 3.066, 3.06
greatest → smallest

Textbook 4 P170

4. Compare the numbers.

Use and to help you.

- (a) Which is greater, 0.58 or 0.6? 0.6
(b) Which is smaller, 0.456 or 0.465? 0.456
(c) Which is the greatest, 0.371, 0.173 or 0.713? 0.713
(d) Which is the smallest, 3.76, 3.067 or 3.076? 3.067

5. Arrange the decimals in decreasing order.

Use a number line to help you.

- (a) 1.37, 1.371, 1.731 1.731, 1.371, 1.37
(b) 3, 3.02, 3.014, 3.023 3.023, 3.02, 3.014, 3

6. Arrange the decimals in increasing order.

Use a number line to help you.

- (a) 1.003, 0.154, 0.64 0.154, 0.64, 1.003
(b) 2.27, 2.3, 2.283, 2.238 2.238, 2.27, 2.283, 2.3

7. What is 0.1 more than 0.3?

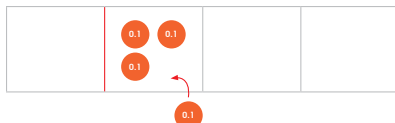

0.4 is 0.1 more than 0.3.

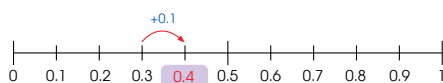

Textbook 4 P171

Using Let's Learn 2, tell pupils that a number line can be used to compare and order numbers. Guide pupils to identify the two numbers on the number line and remind pupils that the number line is arranged in increasing order. Next, demonstrate the comparison.

For Let's Learn 3, guide pupils to align the digits according to their place values. Then demonstrate the comparison starting from the left.

For Let's Learn 4, allow pupils to work in pairs using number and decimal discs to compare.

Use Let's Learn 5 to demonstrate the comparing and ordering of decimals using number lines. Provide more guidance in drawing of the number lines and the marking of numbers on the number line.

Allow pupils to work in pairs for Let's Learn 6. Pupils will practise drawing number lines and marking the numbers on the number line.

For Let's Learn 7, guide pupils to read the question as "What is 1 tenth more than 3 tenths?". Give pupils time to calculate mentally and write the answer on their whiteboard. Then work through the solution using decimal discs and the number line.

8. What is 0.01 less than 0.36?

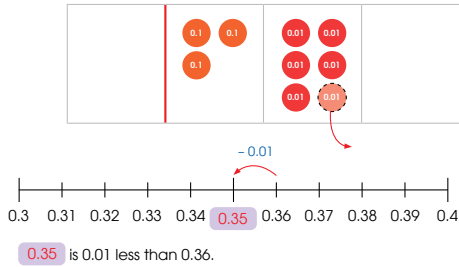

9. What is 0.001 more than 0.023?

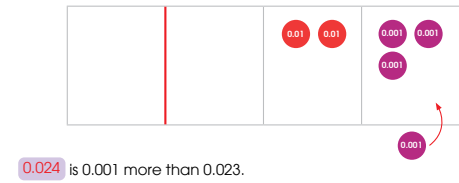

10. Answer the following questions.

- (a) What is 0.1 more than 4.7? **4.8**
 (b) What is 0.01 less than 0.39? **0.38**
 (c) What is 0.001 more than 1.025? **1.026**



Textbook 4 P172

Repeat the same process for Let's Learn 8. The question should be read as "What is 1 hundredth less than 36 hundredths?"

Repeat the same process for Let's Learn 9. The question should be read as "What is 1 thousandth more than 23 thousandths?"

For Let's Learn 10, allow pupils to work in pairs. Get pupils to read the question aloud, work mentally and use number discs to check their answers.

11. What are the missing numbers in the pattern? Explain how you get your answers.

- (a) 0.3, 0.6, 0.9, 1.2, **1.5**, **1.8**
 (b) 2.22, 2.24, 2.26, **2.28**, **2.3**, 2.32, 2.34
 (c) **1.375**, **1.37**, 1.365, 1.360, 1.355, 1.350
 (d) 7.382, 7.362, 7.342, 7.322, **7.302**, **7.282**

Try creating a number pattern using decimals.



Play in groups of 3 to 5.

1 Copy the following place-value chart on your .

Ones	Tenths	Hundredths	Thousandths
0			

- 2 Shuffle and place the **9** face down.
 3 Draw three cards, one at a time. Each time a card is drawn, each player has to decide where to write the digit in their place-value chart. The digit cannot be changed once it is written down.
 4 Compare your number with the other players. The player with the greatest number gets 1 point.
 5 Repeat **2** to **4**. The first player to get 4 points wins!

ACTIVITY TIME

What you need:



ACTIVITY TIME

For Let's Learn 11, guide pupils with these hints:

- Are the numbers in increasing or decreasing order?
- What do you add or subtract to get the next number?
- Can you use the same rule to continue the pattern?

The game enables pupils to think of a strategy, with an element of chance, when placing the number in the place-value chart. For class discussion, ask the winners to share their strategies.

Textbook 4 P173



- Which is greater, 0.459 or 0.457? **0.459**
- Which is smaller, 0.903 or 0.930? **0.903**
- Which is the greatest?
7.635, 6.735, 7.563 **7.635**
- Which is the smallest?
20.919, 20.191, 20.119 **20.119**
- Arrange the decimals in increasing order.
(a) 0.107, 0.033, 0.103 **0.033, 0.103, 0.107**
(b) 3.462, 4.362, 3.463, 4.02 **3.462, 3.463, 4.02, 4.362**
- Arrange these numbers in decreasing order.
(a) 5.500, 0.550, 5.050 **5.500, 5.050, 0.550**
(b) 4.018, 4.108, 4.18, 4.801 **4.801, 4.18, 4.108, 4.018**
- Answer the following.
(a) 0.1 more than 8.8 is **8.9**.
(b) 0.01 less than 1.894 is **1.884**.
(c) 0.001 more than 6.435 is **6.436**.
- Complete the number patterns.
(a) 0.563, 0.560, 0.557, 0.554, **0.551**, **0.548**
(b) **3.516**, 3.514, 3.512, **3.51**, 3.508, 3.506, 3.504

Complete Workbook 4B Worksheet 4 • Pages 17 – 20

Textbook 4 P174



Work with pupils on the practice questions.

For better understanding, select items from **Worksheet 4** and work these out with the pupils.

Independent seatwork

Assign pupils to complete Worksheet 4 (Workbook 4B P17 – 20).

Answers Worksheet 4 (Workbook 4B P17 – 20)

- (a) **4** tenths is greater than **3** tenths.
0.4 is greater than **0.3**.
The **cake** is heavier than the **bread loaf**.
(b) **9** hundredths is greater than **6** hundredths.
0.09 is greater than **0.06**.
Weiming is taller than **Raju**.
- 0.06** is greater than **0.03**.
1.239 is smaller than **1.265**.
- (a) 2.9
(b) 6.94
(c) 7.1
- (a) 8.09
(b) 13.9
(c) 4.909
- (a) 9.899, 9.988, 9.998
(b) 6.8, 6.91, 6.937, 6.94
- (a) 6.3, 6.03, 6.003
(b) 4.9, 4.886, 4.683, 4.68
- (a) 10
(b) 5
(c) 84.051
(d) 7.9
(e) 11.452
(f) 23.568
- (a) 1.2, 1.22
(b) 0.553, 0.543
(c) 3.844, 3.828
(d) 32.065, 33.565

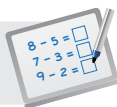
**Specific Learning Focus**

- Compare and order decimals.

Suggested Duration

4 periods

Prior Learning

Pupils should be well-versed with the concept of comparing and ordering numbers and fractions. In this lesson, pupils learn to compare and order decimals.

Pre-emptive Pitfalls

The common misconception among pupils is that the more decimal places there are in a number, the greater the number. In this lesson, decimals are compared by aligning the digits according to their place values in a place-value chart. Emphasise that when comparing decimals less than 1, we start comparing the tenths first.

Introduction

To compare decimals less than 1, guide pupils to use the place-value chart and start comparing the digits in the tenths place first. To compare decimals greater than 1, we first compare the whole numbers and if the whole numbers are the same, we move on to compare the tenths. Reinforce that comparison starts from the left. In Let's Learn 2 (Textbook 4 P170), a number line is used to compare the numbers. In other examples like Let's Learn 3 (Textbook 4 P170), it is easier to use a place-value chart to compare the numbers as they have different number of decimal places. Decimal discs are also useful in comparing and ordering decimals.

Problem Solving

The questions in 'Practice' (Textbook 4 P174) can be done on the board before getting pupils to do the questions as independent seatwork. Encourage pupils to use their preferred method (number line, number and decimal discs, or place-value chart).

Activities

In 'Activity Time' (Textbook 4 P173), have the pupils play in groups of 3 to 5. Give them 10 minutes to carry out this activity in class.

Resources

- number discs (Activity Handbook 4 P5)
- decimal discs (Activity Handbook 4 P37)
- numeral cards (Activity Handbook 4 P44)
- mini whiteboard
- place-value charts (Activity Handbook 4 P38)
- number lines (Activity Handbook 4 P40, 43)

Mathematical Communication Support

Ask pupils questions and have them verbalise the answers, for example:

- What is 1 tenth more than 3 tenths?
- What is 1 thousandth more than 23 thousandths?

In Let's Learn 11 (Textbook 4 P173), to complete the pattern, lead pupils to find the difference between two consecutive numbers.

LESSON

5

ROUNDING DECIMALS

LEARNING OBJECTIVE

1. Round numbers to the nearest whole number, 1 decimal place and 2 decimal places.

ROUNDING DECIMALS

LESSON
5

IN FOCUS



9.4 kg



36.75 kg



6.5 kg

What is the mass of each basket of fruits when rounded to the nearest kilogram?

LET'S LEARN

Rounding to the nearest whole number

1. The basket of bananas weighs 9.4 kg.

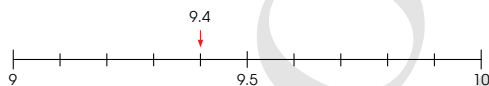

9.4 is between 9 and 10.
It is nearer to 9 than to 10.

$$9.4 \approx 9$$

The mass of the bananas is
about 9 kg.

The sign \approx means
approximately equal to.

Look at the digit in the tenths
place to round a decimal to the
nearest whole number.



IN FOCUS

Review rounding whole numbers in Chapter 1. Discuss and create awareness in pupils that very often we do not give exact mass/measurement. We round the numbers to the nearest whole number.

LET'S LEARN

Rounding to the nearest whole number

For Let's Learn 1, ask pupils what are the whole numbers immediately before and after 9.4. Teacher can draw a number line on the board and ask a pupil to mark 9.4 on it. Ask pupils which whole number is nearer to 9.4. Then guide them through the process of rounding.

Textbook 4 P175

2. The basket of mangoes weighs 36.75 kg.

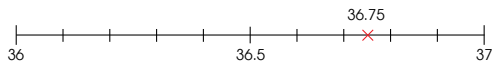

36.75 is between 36 and 37.
It is nearer to 37 than to 36.

$$36.75 \approx 37$$

The mass of the mangoes is about 37 kg.

3. The basket of cherries weighs 6.5 kg.



6.5 is exactly halfway between 6 and 7.
We round it up to 7 to the nearest kilogram.

$$6.5 \approx 7$$

The mass of the cherries is about 7 kg.

4. Round each decimal to the nearest whole number.

(a) $0.6 \approx 1$

(b) $4.5 \approx 5$

(c) $5.72 \approx 6$

(d) $10.08 \approx 10$

Use a number line to help you.



Repeat the same process for Let's Learn 2 and 3.
Summarise the strategies of rounding to the nearest whole number by looking at the digit in the tenths place.

Give pupils sufficient time to work on Let's Learn 4 before going through.

Rounding to 1 decimal place

5. A giraffe has a height of 4.71 m.
What is its height when rounded to 1 decimal place?

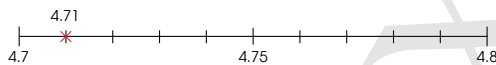

4.71 is between 4.7 and 4.8.
It is nearer to 4.7 than to 4.8.

$$4.71 \approx 4.7$$

The giraffe's height is about 4.7 m.

When rounding to 1 decimal place, look at the digit in the hundredths place only.



6. Round 12.45 to the nearest tenth.

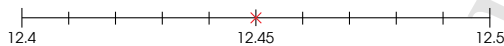

12.45 is exactly halfway between 12.4 and 12.5.

$$12.45 \approx 12.5$$

Rounding to the nearest tenth is the same as rounding to 1 decimal place.



Rounding to 1 decimal place

For Let's Learn 5, ask pupils which are the 1-place decimals just before and after 4.71. Draw the number line and select a pupil to mark 4.71 on it. Then guide pupils through the process of rounding.

Using Let's Learn 6, explain to the pupils that rounding to the nearest tenth is the same as rounding to 1 decimal place.

7. Round 0.984 to 1 decimal place.

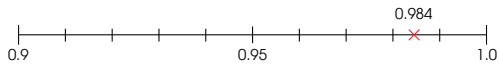

0.984 is between 0.9 and 1.0.

It is nearer to 1.0 than 0.9.

$0.984 \approx 1.0$

8. Round each decimal to the nearest tenth.

- (a) 0.44 **0.4** (b) 0.08 **0.1**
 (c) 7.65 **7.7** (d) 3.99 **4.0**

Use a number line to help you.



Rounding to 2 decimal places

9. A bottle contains 0.761 ℓ of water. Round the volume to the nearest 0.01 ℓ.

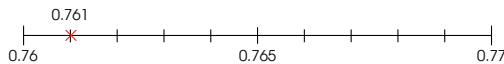

0.761 is between 0.76 and 0.77. It is nearer to 0.76 than to 0.77.

Look at the digit in the thousandths place to round a number to 2 decimal places.

$0.761 \approx 0.76$

The volume of water in the bottle is about 0.76 ℓ.



Textbook 4 P178

For Let's Learn 7, help pupils see that the next 1-place decimal after 0.984 is 1 or 1.0. Guide pupils to fill in the blanks.

Allow pupils to work on Let's Learn 8 before going through.

Rounding to 2 decimal places

For Let's Learn 9, ask pupils to identify the 2-place decimals just before and after 0.761. Then repeat the same process to guide pupils to round to 2 decimal places.

10. Round 2.475 to 2 decimal places.

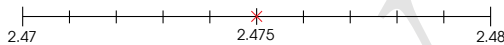

2.475 is exactly halfway between 2.47 and 2.48.

$2.475 \approx 2.48$

11. Round 13.996 to the nearest hundredth.

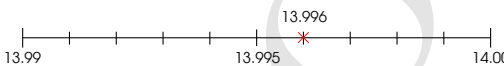

13.996 is between 13.99 and 14.00.

It is nearer to 14.00 than to 13.99.

$13.996 \approx 14$

Rounding to the nearest hundredth is the same as rounding to 2 decimal places.



12. Round each decimal to the nearest hundredth.

- (a) 0.248 **0.25** (b) 0.095 **0.10**
 (c) 7.865 **7.87** (d) 4.997 **5.00**

Use a number line to help you. Which digit do you look at?



Textbook 4 P179

For Let's Learn 10 and 11, guide pupils through the same process to round a 3-place decimal to 2 decimal places.

Use Let's Learn 11 to explain that rounding to 2 decimal places is the same as rounding to the nearest hundredth.

Give similar examples in Let's Learn 12 for pupils to work on.

Work in groups of 3 to 4.

ACTIVITY  TIME

Measure in centimetres

- 1 Measure small objects in your classroom with a .
- 2 Record the reading to 1 decimal place.
- 3 Round each reading to the nearest centimetre.

What you need:

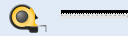

Measure in metres

- 1 Measure large objects in your classroom with a .
- 2 Record the reading to 2 decimal places.
- 3 Round each reading to 1 decimal place.

PRACTICE 

1. Round each decimal to the nearest whole number.
 (a) 9.4 **9** (b) 65.8 **66**
 (c) 10.05 **10** (d) 20.95 **21**
2. Round each decimal to 1 decimal place.
 (a) 45.04 **45.0** (b) 9.95 **10.0**
 (c) 2.567 **2.6** (d) 1.049 **1.0**
3. Round each decimal to 2 decimal places.
 (a) 16.986 **16.99** (b) 2.185 **2.19**
 (c) 4.504 **4.50** (d) 3.916 **3.92**

 Complete Workbook 4B Worksheet 5 • Pages 21 – 24

OXFORD
UNIVERSITY PRESS

DECIMALS (1) **180**

Textbook 4 P180

The activity gives pupils the opportunity to read measurements and then round these measurements.

PRACTICE 

Work with pupils on the practice questions.

For better understanding, select items from **Worksheet 5** and work these out with the pupils.

Independent seatwork

Assign pupils to complete Worksheet 5 (Workbook 4B P21 – 24).

Answers Worksheet 5 (Workbook 4B P21 – 24)

1. (a) 4, 5
 (b) 3, 4
2. (a) 8.6, 8.7
 (b) 10.4, 10.4
3. (a) 3.27, 3.28
 (b) 5.01, 5.04
4. 50.5 ml \approx 51 ml
5. 120.98 g \approx 121g
6. 2.18 m \approx 2.2 m
7. 4.236 l \approx 4.2 l
8. 8.954 kg \approx 8.95 kg
9. 21.164 km \approx 21.16 km

**Specific Learning Focus**

- Round numbers to the nearest whole number, 1 decimal place and 2 decimal places.

Suggested Duration

4 periods

Prior Learning

Rounding numbers is a concept learnt in Chapter 1. They should be aware of the approximation symbol ' \approx ', which is used when a number is rounded or when a number is estimated.

Pre-emptive Pitfalls

Some pupils may find this lesson challenging. On the board, write numbers to be rounded and elicit individual responses. For pupils who struggle with understanding the concept, provide them with cues and hints to lead them to the correct answer.

Introduction

Use number lines to help pupils round numbers. Emphasise the following points:

- Identify the two numbers to be placed as the smallest and greatest numbers on the number line.
- Find the middle value that is exactly in between the first and last numbers and indicate it on the number line.
- To round a decimal, look at the digit in the decimal place after the digit in the place that the decimal is to be rounded to (i.e. if a decimal is to be rounded to the nearest whole number, we look at the digit in the tenths place).
- If the digit is 5 or more, then we round to the greatest value.
- If the digit is less than 5, then we round to the smallest value.

Problem Solving

Emphasise to pupils that to round off to the:

- nearest whole number – look at the first decimal place
- nearest 1 d.p. – look at the second decimal place
- nearest 2 d.p. – look at the third decimal place

Activities

Pupils are required to use a ruler and measuring tape in 'Activity Time' (Textbook 4 P180). Ask them to use a ruler to measure in centimetres and a measuring tape to measure in metres. Give them the instructions to round the measurements to 1 or 2 d.p. in centimetres and metres. Let them work in groups of 3 to 4. Encourage each group to use their preferred method for the activity and get them to form groups according to their preferred method.

Resources

- ruler
- measuring tapes
- mini whiteboard
- markers

Mathematical Communication Support

Emphasise to pupils that the steps to rounding a number is the same no matter whether it is to be rounded to the nearest whole number or no matter the number of decimal places.

FRACTIONS AND DECIMALS

LEARNING OBJECTIVES

1. Convert fraction to decimal when the denominator of the fraction is a factor of 10 or 100.
2. Convert decimal to fraction.

FRACTIONS AND DECIMALS

LESSON
6

IN FOCUS



A photo frame has a length of $\frac{1}{2}$ m.
How do we write the length of the photo frame as a decimal?

LET'S LEARN

1.

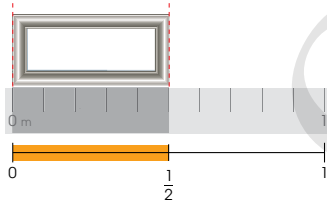

Using a metre ruler, the length of the photo frame is $\frac{1}{2}$ m.

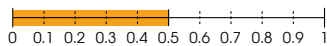

$$\frac{1}{2} = \frac{5}{10} = 0.5$$

$\frac{1}{2}$ m written as a decimal is 0.5 m.

We convert the denominator to 10 to find the number of tenths.

$$\frac{1}{2} \xrightarrow{\times 5} \frac{5}{10}$$



IN FOCUS

Review with pupils:

$$1 \text{ tenth} = \frac{1}{10} = 0.1$$

$$1 \text{ hundredth} = \frac{1}{100} = 0.01$$

$$1 \text{ thousandth} = \frac{1}{1000} = 0.001$$

LET'S LEARN

For Let's Learn 1, apply the same strategy as Lesson 1 (P148). Guide pupils to see that the 1 metre ruler is divided into 10 equal parts. The length of the photo frame at $\frac{1}{2}$ m is equal to 5 out of 10 equal parts:

$$\frac{1}{2} = \frac{5}{10} = 5 \text{ tenths or } 0.5$$

Next, lead pupils to see that the denominator, 2, is a factor of 10. To convert the denominator to 10, we need to multiply both the numerator and denominator by 5 to obtain its equivalent fraction.

2. Express $\frac{1}{5}$ as a decimal.

$$\frac{1}{5} = \frac{2}{10} \\ = 0.2$$

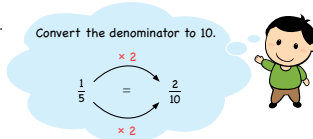

3. Express $\frac{1}{4}$ as a decimal.

$$\frac{1}{4} = \frac{25}{100} \\ = 0.25$$

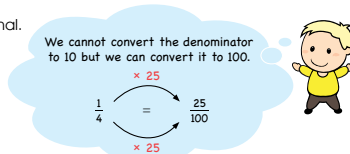

4. Express $\frac{9}{20}$ as a decimal.

$$\frac{9}{20} = \frac{45}{100} \\ = 0.45$$

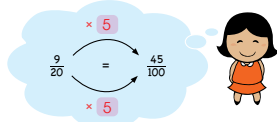

5. Express $1\frac{1}{2}$ as a decimal.

$$1\frac{1}{2} = 1\frac{5}{10} \\ = 1.5$$

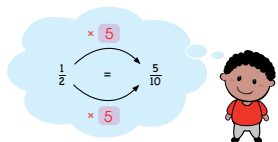

OXFORD
UNIVERSITY PRESS

DECIMALS (1) 182

Textbook 4 P182

For Let's Learn 2, lead pupils to see that 5 is also a factor of 10. Apply the same strategy as Let's Learn 1 and guide pupils to fill in the blank.

In Let's Learn 3, lead pupils to see that 4 is not a factor of 10 but it is a factor of 100. To convert 4 to 100, we need to multiply both the numerator and denominator by 25 ($100 \div 4 = 25$).

After teacher's exposition in Let's Learn 1 to 3, get pupils to work in pairs to solve example 4 to 6 first before going through. Select pupils to fill in the missing numbers and explain their answers.

6. Express $2\frac{3}{4}$ as a decimal.

$$2\frac{3}{4} = 2\frac{75}{100} \\ = 2.75$$

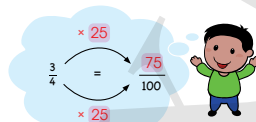

7. Express 0.6 as a fraction in its simplest form.

$$0.6 = \frac{6}{10} \\ = \frac{3}{5}$$

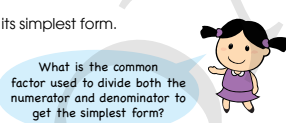

8. Express 0.35 as a fraction in its simplest form.

$$0.35 = \frac{35}{100} \\ = \frac{7}{20}$$

9. Express 3.25 as a mixed number in its simplest form.

$$3.25 = 3\frac{25}{100} \\ = 3\frac{1}{4}$$

10. Express each of the following as a fraction or a mixed number. Leave each answer in its simplest form.

(a) $0.8 = \frac{4}{5}$ (b) $0.25 = \frac{1}{4}$
 (c) $2.6 = 2\frac{3}{5}$ (d) $5.45 = 5\frac{9}{20}$

183 CHAPTER 8

OXFORD
UNIVERSITY PRESS

Textbook 4 P183

Use Let's Learn 7 to demonstrate the conversion of a 1-place decimal to a fraction. Then guide pupils to simplify $\frac{6}{10}$ by finding the common factor of numerator and denominator (6 and 10).

Repeat the same process for Let's Learn 8. Convert the 2-place decimal to a fraction and simplify it.

Repeat the same process for Let's Learn 9. Convert the decimal to a mixed number and simplify it.

Get pupils to work in pairs for Let's Learn 10. Remind pupils to express each decimal as a fraction or mixed number on their whiteboard and leave each answer in its simplest form.



1. Express each of the fractions as a decimal.

- (a) $\frac{3}{5} = 0.6$ (b) $3\frac{1}{2} = 3.5$
 (c) $\frac{3}{20} = 0.15$ (d) $5\frac{3}{4} = 5.75$

2. Express each of the following as a fraction or a mixed number. Leave each answer in its simplest form.

- (a) $0.05 = \frac{1}{20}$ (b) $0.13 = \frac{13}{100}$
 (c) $2.04 = 2\frac{1}{25}$ (d) $7.35 = 7\frac{7}{20}$

Complete Workbook 4B, Worksheet 6 • Pages 25 – 27



MIND WORKOUT

The cost of a beef burger is rounded to the nearest dollar. It costs approximately \$4. What is the highest and lowest possible cost of the beef burger?

When we round to the nearest dollar, we round the cost to the nearest whole number.

Use a number line to help you.

Answer: \$4.49 and \$3.50



Textbook 4 P184



Work with pupils on the practice questions.

For better understanding, select items from **Worksheet 6** and work these out with the pupils.

Independent seatwork

Assign pupils to complete Worksheet 6 (Workbook 4B P25 – 27).

Answers

Worksheet 6 (Workbook 4B P25 – 27)

1. (a) $\frac{2}{5} = \frac{40}{100}$
 $= 0.04$

(b) $\frac{11}{20} = \frac{55}{100}$
 $= 0.55$

(c) $\frac{7}{50} = 0.14$

(d) $\frac{6}{25} = 0.24$

2. (a) $1\frac{3}{4} = 1\frac{75}{100}$
 $= 1.75$

(b) $2\frac{14}{25} = 2.56$

(c) $5\frac{1}{2} = 5.5$

(d) $6\frac{6}{20} = 6.3$

3. (a) $0.2 = \frac{1}{5}$

(b) $0.50 = \frac{1}{2}$

(c) $0.09 = \frac{9}{100}$

(d) $1.25 = 1\frac{1}{4}$

(e) $3.20 = 3\frac{1}{5}$

(f) $5.05 = 5\frac{1}{20}$

(g) $1.23 = 1\frac{23}{100}$

(h) $2.68 = 2\frac{17}{25}$



Specific Learning Focus

- Convert fraction to decimal when the denominator of the fraction is a factor of 10 or 100.
- Convert decimal to fraction.

Suggested Duration

2 periods

Prior Learning

Pupils have learnt how to convert a mixed number to an improper fraction and vice versa, and to form equivalent fractions. This lesson involves a continuation of these concepts.

Pre-emptive Pitfalls

Conversion of fractions to decimals and vice versa, are linked to equivalence fractions, and multiples of 10 come in as an important concept to be used when converting decimals to fractions and vice versa.

Introduction

Explain the concept of conversions by emphasising the following points:

- 1-place, 2-place and 3-place decimals are fractions with the denominator 10, 100 and 1000 respectively.
- To convert fractions to decimals, the denominator needs to be a factor of 10.
- In order to do so, identify the common factor that both the numerator and denominator are to be multiplied by.

Show pupils this template to guide them in obtaining an equivalent fraction with a denominator that is a factor of 10:

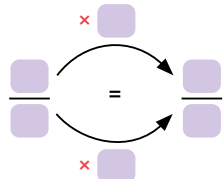

Provide pupils with the conversion of fraction cards for their independent seatwork. Get them to use markers to answer the questions in 'Let's Learn' (Textbook 4 P182 – 183) on the cards.

Problem Solving

Give pupils a few standard conversions to memorise:

$$\frac{1}{4} \longrightarrow \frac{25}{100} \longrightarrow 0.25$$

$$\frac{1}{2} \longrightarrow \frac{50}{100} \longrightarrow 0.5$$

$$\frac{3}{4} \longrightarrow \frac{75}{100} \longrightarrow 0.75$$

Activities

Use 'Maths Journal' (Textbook 4 P185) as an activity template and ask pupils to draw their own diagrams and share with the class.

Resources

- conversion of fraction cards (Activity Handbook 4 P45)
- decimal cards (Activity Handbook 4 P46)

Mathematical Communication Support

Verbalise the process of conversion using key terms like 'equivalent fractions', 'multiples', 'factors', 'multiply', 'divide', 'tenths', 'hundredths' and 'thousandths'. Elicit individual responses to find the factor that both the numerator and denominator are to be multiplied by to obtain an equivalent fraction. Emphasise that while converting fractions to decimals and vice versa, the answer should be a proper fraction or a mixed number in its simplest form.

PROBLEM SOLVING, MATHS JOURNAL AND PUPIL REVIEW

PRACTICE 

1. Express each of the fractions as a decimal.

(a) $\frac{3}{5}$ 0.6 (b) $3\frac{1}{2}$ 3.5

(c) $\frac{3}{20}$ 0.15 (d) $5\frac{3}{4}$ 5.75

2. Express each of the following as a fraction or a mixed number.
Leave each answer in its simplest form.

(a) 0.05 $\frac{1}{20}$ (b) 0.13 $\frac{13}{100}$

(c) 2.04 $2\frac{1}{25}$ (d) 7.35 $7\frac{7}{20}$

Complete Workbook 4B, Worksheet 6 • Pages 25 – 27

MIND WORKOUT 

The cost of a beef burger is rounded to the nearest dollar.
It costs approximately \$4.
What is the highest and lowest possible cost of the beef burger?

When we round to the nearest dollar, we round the cost to the nearest whole number.

Use a number line to help you.

Answer: \$4.49 and \$3.50



OXFORD UNIVERSITY PRESS
DECIMALS (1) 184



MIND WORKOUT

To facilitate the activity, explain to pupils that money is expressed as a 2-place decimal.

Textbook 4 P184

(e) $3.20 = 3\frac{2}{5}$	(f) $5.05 = 5\frac{1}{20}$
(g) $1.23 = 1\frac{23}{100}$	(h) $2.68 = 2\frac{17}{25}$



Mind Workout

Allow pupils to work in pairs or groups to solve the puzzle.



Mind Workout

Date: _____

The decimals in a path from A to B are arranged in increasing order. Colour to show the path.

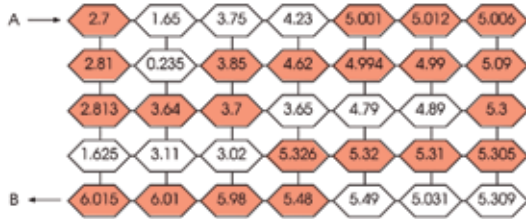

Decimals II 27

Workbook 4B P27

MATHS JOURNAL

Which of these numbers has the greatest value?

0.8

0.80

0.800

Explain your answer.
You may use diagrams to show the comparison of these numbers.

I know how to...

- read and write decimals up to 3 decimal places.
- tell the value of a digit in a decimal.
- compare and order decimals. round decimals.
- express a fraction as a decimal.
- express a decimal as a fraction.

SELF-CHECK



185 CHAPTER 8

OXFORD UNIVERSITY PRESS

Textbook 4 P185

MATHS JOURNAL

This is an open-ended question. The aim is for pupils to conclude that:

8 tenths = 80 hundredths = 800 thousandths

Pupils may use the place-value chart, decimal discs, fraction or drawing to show that the three numbers are equivalent.



Maths Journal

Melling is helping Ahmad with this question.

Round 5.37 to the nearest tenth.

She writes $5.37 \approx 5.4$.

Ahmad wants to know why Melling changes the digit from 3 to 4 and drops the digit 7 from the answer.

If you were Melling, how can you help Ahmad to understand this question?

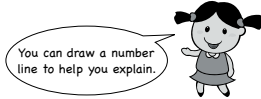

Workbook 4B P28



Maths Journal

This is another open-ended question. Pupils will demonstrate their understanding of rounding decimal through their explanation.

MATHS JOURNAL

Which of these numbers has the greatest value?

0.8

0.80

0.800

Explain your answer.
You may use diagrams to show the comparison of these numbers.

I know how to...

- read and write decimals up to 3 decimal places.
- tell the value of a digit in a decimal.
- compare and order decimals. round decimals.
- express a fraction as a decimal.
- express a decimal as a fraction.

SELF-CHECK



This self-check can be done after pupils have completed **Review 8** (Workbook 4B P29 – 32).

SELF-CHECK



Textbook 4 P185

1. (a) 0.59
(b) 7.8
(c) 50.009
(d) 2.264

2. (a) 3.5
(b) 4.03
(c) 7.32
(d) 8.1
(e) 1.64
(f) 2.058

3. (a) 11.53
(b) 0.218

4. (a) 0.4
(b) 1.35

5. 25.46

- 6 0.005

7. (a) 0.8
(b) $\frac{1}{1000}$

8. (a) 0.28, 0.82, 8.02, 8.2
(b) $\frac{1}{2}$, 0.405, 0.054, 0.045

9. (a) 16
(b) 8.6
(c) 62.14

10. (a) 0.45
(b) 3.56
(c) 2.8

11. (a) $\frac{9}{20}$
(b) $1\frac{1}{4}$

OXFORD
UNIVERSITY PRESS

DECIMALS (II)

CHAPTER

9

Decimals (II) CHAPTER **9**

How much cooking oil is there on the table?

ADDING DECIMALS LESSON **1**

IN FOCUS

How much cooking oil is there altogether?

OXFORD UNIVERSITY PRESS DECIMALS (II) **186**

Textbook 4 P186

Related Resources

NSPM Textbook 4 (P186 – 217)
NSPM Workbook 4B (P33 – 60)

Materials

Number and decimal discs, dice, supermarket advertisement, markers, mini whiteboard

Lesson

Lesson 1 Adding Decimals
Lesson 2 Subtracting Decimals
Lesson 3 Multiplying Decimals
Lesson 4 Dividing Decimals
Lesson 5 Solving Word Problems
Problem Solving, Maths Journal and Pupil Review

INTRODUCTION

The standard algorithms for the four operations of whole numbers are extended to decimals in Grade Four. Concept of place value is important when performing the addition and subtraction algorithms. Pupils also need to have a mastery of the multiplication facts and renaming concepts to multiply/divide a decimal. Learning experiences include the use of number and decimal discs which will help pupils relate to the process of renaming. Word problems are set in real-life context. Pupils will estimate (to check for reasonableness of answer) and apply the four operations of decimals to solve them.

LEARNING OBJECTIVE

1. Add decimals of up to 2 decimal places.

Decimals (II) CHAPTER 9

How much cooking oil is there on the table?

ADDING DECIMALS

IN FOCUS

How much cooking oil is there altogether?

OXFORD UNIVERSITY PRESS

DECIMALS (II) LESSON 1 186

IN FOCUS

Using the Chapter Opener, discuss with the class what kind of questions you can ask from the picture.

- How much meat is there on the table?
- How much cooking oil is there on the table?

Textbook 4 P186

LET'S LEARN

1. Add 0.7 and 0.2.



$$\begin{array}{r} 0.7 \\ + 0.2 \\ \hline 0.9 \end{array}$$

There is 0.9 ℓ of cooking oil altogether.

7 tenths + 2 tenths = 9 tenths
0.7 + 0.2 = 0.9



2. Add.

(a)
$$\begin{array}{r} 0.3 \\ + 0.4 \\ \hline 0.7 \end{array}$$

(b)
$$\begin{array}{r} 1.2 \\ + 0.7 \\ \hline 1.9 \end{array}$$

(c)
$$\begin{array}{r} 5.1 \\ + 3.8 \\ \hline 8.9 \end{array}$$

(d)
$$\begin{array}{r} 4.6 \\ + 2.3 \\ \hline 6.9 \end{array}$$

3. Add 0.4 to 0.8.

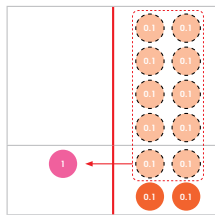

Step 1 Add the tenths. 8 tenths + 4 tenths = 12 tenths
Rename 12 tenths as 1 one 2 tenths.



$$\begin{array}{r} 0.8 \\ + 0.4 \\ \hline 1.2 \end{array}$$

Pose the question from the In Focus to the pupils. Ask pupils for the number equation for Let's Learn 1. Then, using decimal discs illustrate the addition algorithm of 1-place decimals without renaming. Focus pupils' attention on the alignment of the digits and the decimal points.

Work through Let's Learn 2(a) and (b) with the class and allow pupils to work on 2(c) and (d) on their whiteboard. Check that pupils align the decimal points and digits correctly.

Let's Learn 3 features the addition of a 1-place decimals with renaming. Illustrate the algorithm step-by-step. Use number and decimal discs to help pupils relate to the process of renaming (exchange 10  for 1 ).

Step 2 Add the ones. 1 one + 0 ones = 1 one

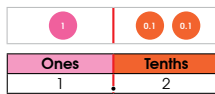

$$0.8 + 0.4 = 1.2$$

$$\begin{array}{r} 0.8 \\ + 0.4 \\ \hline 1.2 \end{array}$$

4. Add.

(a)
$$\begin{array}{r} 0.9 \\ + 0.7 \\ \hline 1.6 \end{array}$$

(b)
$$\begin{array}{r} 1.6 \\ + 0.5 \\ \hline 2.1 \end{array}$$

(c)
$$\begin{array}{r} 2.8 \\ + 2.3 \\ \hline 5.1 \end{array}$$

(d)
$$\begin{array}{r} 1.5 \\ + 4.9 \\ \hline 6.4 \end{array}$$

5. Add 0.07 and 0.04.

Step 1 Add the hundredths.
7 hundredths + 4 hundredths = 11 hundredths
Rename 11 hundredths as 1 tenth 1 hundredth.

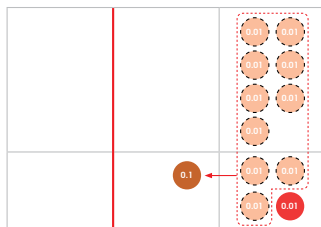

$$\begin{array}{r} 0.07 \\ + 0.04 \\ \hline 0.11 \end{array}$$

Select pupils to solve Let's Learn 4(a) and (b). Demonstrate renaming using number and decimal discs. Give pupils sufficient time to work on 4(c) and (d). Use pupils' errors as teaching points.

Let's Learn 5 features the addition of a 2-place decimals with renaming. Ask pupils to mentally add 7 hundredths to 4 hundredths (11 hundredths). Then illustrate the algorithm using decimal discs. Focus pupils' attention on the renaming process. Write the answer on a place-value chart.

Step 2 Add the tenths. 1 tenth + 0 tenths = 1 tenth

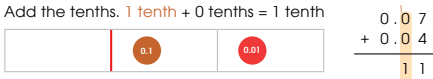

Step 3 Add the ones.

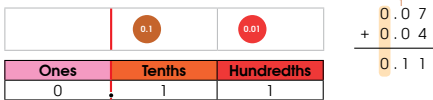

$$0.07 + 0.04 = 0.11$$

6. Find the sum of 2.6 and 6.78.

First, estimate the answer.

$$\begin{aligned} 2.6 &\approx 3 \\ 6.78 &\approx 7 \\ 3 + 7 &= 10 \end{aligned}$$

$$\begin{array}{r} 2.60 \\ + 6.78 \\ \hline 9.38 \end{array}$$

Align the decimal points and insert a zero to even out the number of decimal places.

Step 1 Add the hundredths.
0 hundredths + 8 hundredths = 8 hundredths

Step 2 Add the tenths.
6 tenths + 7 tenths = 13 tenths
Rename 13 tenths as 1 one 3 tenths.

Step 3 Add the ones.
1 one + 2 ones + 6 ones = 9 ones

$$2.6 + 6.78 = 9.38$$

9.38 is near 10.
The answer is reasonable.

Find the sum of 260 and 678.
How is your working similar to the working for 2.6 + 6.78?

189 CHAPTER 9

OXFORD UNIVERSITY PRESS

Textbook 4 P189

The focus of Let's Learn 6 is to teach pupils to even out the number of decimal places by inserting zero and to estimate the answer.

Estimate the answer with the class by rounding to the nearest whole number. Then ask pupils to write the addition in vertical form and check their alignment. Work through the algorithm with the class by showing them how to even out the decimal by inserting a zero at the end of 2.6.

Compare the answer to their estimate to check for reasonableness. For class discussion, ask pupils what happens if the digits are not aligned according to their place value;

$$\begin{array}{r} 2.6 \\ + 6.78 \\ \hline \end{array}$$

7. What is the sum of 15.65 and 29.95?

$$\begin{array}{r} 15.65 \\ + 29.95 \\ \hline 45.60 \end{array}$$

First, estimate the answer.

$$15.65 \approx 16$$

$$29.95 \approx 30$$

$$16 + 30 = 46$$

$$15.65 + 29.95 = 45.6$$

Is your answer reasonable?

8. Add.
You may use and to help you.

$$\begin{array}{r} 0.05 \\ + 0.19 \\ \hline 0.24 \end{array}$$

$$\begin{array}{r} 1.68 \\ + 0.34 \\ \hline 2.02 \end{array}$$

$$\begin{array}{r} 3.56 \\ + 2.62 \\ \hline 6.18 \end{array}$$

$$\begin{array}{r} 1.95 \\ + 8.67 \\ \hline 10.62 \end{array}$$

PRACTICE

1. Add.

$$\begin{array}{r} 0.9 \\ + 0.1 \\ \hline 1.0 \end{array}$$

$$\begin{array}{r} 0.07 \\ + 0.05 \\ \hline 0.12 \end{array}$$

2. Find the sum of each pair of numbers.
Check if your answers are reasonable.

(a) 2.63 and 8.5 **11.13** (b) 5.7 and 6.24 **11.94**

(c) 28.09 and 3.65 **31.74** (d) 14.15 and 21.96 **36.11**

Complete Workbook 4B, Worksheet 1 • Pages 33–34

OXFORD UNIVERSITY PRESS

DECIMALS (II) 190

Textbook 4 P190

Let's Learn 7 features the addition of a 2-place decimal with three renaming. Repeat the same process as Let's Learn 6.

Allow pupils to work in pairs for Let's Learn 8. They may use number and decimal discs to help them. Remind pupils to estimate before adding.

PRACTICE

Work through the practice questions with pupils. Check for pupils' mistakes in their addition algorithm and use them for class discussion.

Independent seatwork

Assign pupils to complete Worksheet 1 (Workbook 4B P33–34).

1. (a) 0.9
(b) 1.1
(c) 0.07
(d) 0.10
(e) 0.11
(f) 0.95
(g) 0.85
(h) 1.02

2. (a) 6.91
(b) 10.2
(c) 11.99
(d) 25.08
(e) 57.9
(f) 60.01
(g) 95.98
(h) 29.83

OXFORD
UNIVERSITY PRESS

SUBTRACTING DECIMALS

LEARNING OBJECTIVE

1. Subtract decimals of up to 2 decimal places.

SUBTRACTING DECIMALS

LESSON
2

IN FOCUS

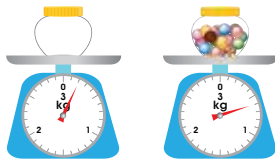

What is the mass of the chocolates?

LET'S LEARN

1. Subtract 0.2 from 0.6.



$$0.6 - 0.2 = 0.4$$

The mass of the chocolates is 0.4 kg.

6 tenths - 2 tenths = 4 tenths



2. Subtract 0.03 from 0.08.



$$0.08 - 0.03 = 0.05$$

8 hundredths - 3 hundredths = 5 hundredths



IN FOCUS

Discuss the problem in the In Focus. Ask pupils for the mass of the empty bottle and the mass of the bottle with chocolates. Then ask for suggestions to solve the problem. Get pupils to write the number equation on their whiteboard.

LET'S LEARN

For Let's Learn 1, get pupils to read the number equation (subtract 2 tenths from 6 tenths). Then use decimal discs to illustrate the subtraction of two 1-place decimals without renaming.

Get pupils to read the subtraction equation in Let's Learn 2 as 'subtract 3 hundredths from 8 hundredths'. Select a pupil to demonstrate the subtraction algorithm using decimal discs.

3. Subtract.

$$\begin{array}{r} 0.7 \\ - 0.3 \\ \hline 0.4 \end{array}$$

$$\begin{array}{r} 0.09 \\ - 0.06 \\ \hline 0.03 \end{array}$$

$$\begin{array}{r} 1.65 \\ - 0.02 \\ \hline 1.63 \end{array}$$

$$\begin{array}{r} 5.48 \\ - 4.43 \\ \hline 1.05 \end{array}$$

4. Subtract 0.08 from 1.23.

Step 1 Rename 1 tenth as 10 hundredths.
Subtract the hundredths.

13 hundredths - 8 hundredths = 5 hundredths

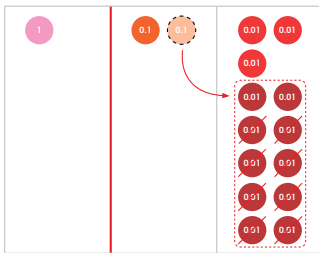

$$\begin{array}{r} 1.23 \\ - 0.08 \\ \hline 1.15 \end{array}$$

OXFORD
UNIVERSITY PRESS

DECIMALS (II) 192

Textbook 4 P192

Work through Let's Learn 3(a) and (b) with the class and get pupils to copy 3(b) and (d) on their whiteboards to solve them.

Let's Learn 4 features the subtraction of 2-place decimals with one renaming. Illustrate the subtraction algorithm using number and decimal discs.

Focus pupils' attention on the renaming i.e. exchange

1 **0.1** for 10 **0.01** to subtract 8 hundredths.

Step 2 Subtract the tenths.

1 tenth - 0 tenths = 1 tenth

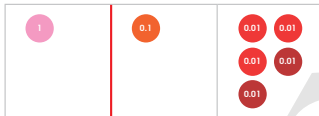

$$\begin{array}{r} 1.23 \\ - 0.08 \\ \hline 1.15 \end{array}$$

Step 3 Subtract the ones.

1 one - 0 ones = 1 one

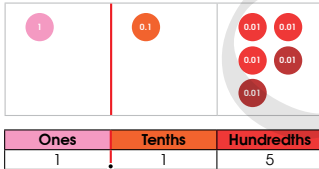

$$\begin{array}{r} 1.23 \\ - 0.08 \\ \hline 1.15 \end{array}$$

$$1.23 - 0.08 = 1.15$$

5. Find the difference between 6.4 and 2.69.

First, estimate the answer.

$$\begin{array}{l} 6.4 \approx 6 \\ 2.69 \approx 3 \\ 6 - 3 = 3 \end{array}$$



193 CHAPTER 9

OXFORD
UNIVERSITY PRESS

Textbook 4 P193

Put the answer shown by the number and decimal discs on a place-value chart and relate it to the answer in the algorithm.

Ask pupils for the meaning of the word 'difference' in Let's Learn 5. Get pupils to identify the greater decimal before writing the subtraction equation vertically on their whiteboard. Then estimate the answer with the class.

$$\begin{array}{r} \overset{5}{6} \overset{13}{.} \overset{10}{4} \overset{10}{9} \\ - 2.69 \\ \hline 3.71 \end{array}$$

Align the decimal points.
6.4 is the same as 6.40.



- Step 1** Rename 1 tenth as 10 hundredths.
Subtract the hundredths.
10 hundredths - 9 hundredths = 1 hundredth
- Step 2** Rename 1 one as 10 tenths.
Subtract the tenths.
10 tenths + 3 tenths = 13 tenths
13 tenths - 6 tenths = 7 tenths
- Step 3** Subtract the ones.
5 ones - 2 ones = 3 ones
6.4 - 2.69 = 3.71

6. Find the value of $22.08 - 2.19$.

$$\begin{array}{r} \overset{11}{2} \overset{9}{2} \overset{10}{0} \overset{10}{8} \\ - 2.19 \\ \hline 19.89 \end{array}$$

$22.08 \approx 22$
 $2.19 \approx 2$
 $22 - 2 = 20$

Is your answer reasonable?



7. Subtract.

You may use and to help you.

(a)
$$\begin{array}{r} \overset{5}{2} \overset{8}{.} \overset{8}{8} \\ - 1.48 \\ \hline 1.08 \end{array}$$

(b)
$$\begin{array}{r} \overset{5}{2} \overset{13}{.} \overset{8}{8} \\ - 4.62 \\ \hline 1.76 \end{array}$$

(c)
$$\begin{array}{r} \overset{6}{7} \overset{12}{.} \overset{10}{8} \overset{10}{0} \\ - 5.95 \\ \hline 1.85 \end{array}$$

(d)
$$\begin{array}{r} \overset{3}{4} \overset{9}{.} \overset{10}{0} \overset{10}{0} \\ - 1.23 \\ \hline 2.77 \end{array}$$

OXFORD
UNIVERSITY PRESS

DECIMALS (II)

194

Textbook 4 P194

Illustrate the insertion of a zero at the end of 6.4 and the formal algorithm step-by-step. Compare the answer to the estimated one to check for reasonableness.

Let's Learn 6 features subtraction with renaming in the tens, ones, tenths and hundredths place. Encourage pupils to estimate the answer before guiding them through the subtraction algorithm. Pay special emphasis on the renaming process for each place value. Check answer against the estimated one for reasonableness.

For Let's Learn 7, allow pupils to work in pairs. They may use number or decimal discs to help them. Remind pupils to estimate the answer.

ACTIVITY TIME

Part A:

Work in groups of 3 to 4.

- Write down the costs of food and drinks found in your school canteen.
- You are given \$3 to spend. Using estimation, pick two items that you are able to buy.
- Share with your group members how you estimate.
- Take turns and repeat 1 to 3.

What you need:



Part B:

Work in pairs.

Discuss how you add and subtract the following mentally.

- (a) $3.56 + 0.9$ (b) $4.35 + 1.42$
(c) $7.48 - 0.5$ (d) $9.13 - 0.96$

PRACTICE

1. Subtract.

(a)
$$\begin{array}{r} 0.17 \\ - 0.04 \\ \hline 0.13 \end{array}$$

(b)
$$\begin{array}{r} 2.09 \\ - 1.32 \\ \hline 0.77 \end{array}$$

2. Find the difference between each pair of numbers. Check if your answers are reasonable.

- (a) 8.63 and 6.59 **2.04** (b) 7 and 5.42 **1.58**
(c) 38.9 and 3.65 **35.25** (d) 30 and 5.84 **24.16**

Complete Workbook 4B, Worksheet 2 • Pages 35 – 38

195

CHAPTER 9

OXFORD
UNIVERSITY PRESS

Textbook 4 P195

ACTIVITY TIME

Part A

Working in groups, pupils will record prices of food and drinks in the canteen. They will use estimation to maximise their purchase within \$3.

Part B

Working in pairs, pupils are encouraged to add and subtract mentally.

PRACTICE

Work through the practice questions with pupils. Use pupils' errors for class discussion to rectify them.

Independent seatwork

Assign pupils to complete Worksheet 2 (Workbook 4B P35 – 38).

1. (a) 0.5
(b) 0.30
(c) 0.03
(d) 0.03
(e) 0.33
(f) 0.16
(g) 0.25
(h) 0.36

2. (a) 6.9
(b) 0.76
(c) 5.27
(d) 1.79
(e) 10.82
(f) 8.03
(g) 37.23
(h) 85.78

3. (a) $7.84 - 0.9 = 6.94$
(b) $32.14 - 16.09 = 16.05$
(c) $45.3 - 28.76 = 16.54$

OXFORD
UNIVERSITY PRESS

**Specific Learning Focus**

- Add decimals of up to 2 decimal places.
- Subtract decimals of up to 2 decimal places.

Suggested Duration

Lessons 1 & 2: 10 periods

Prior Learning

Pupils should be well-versed with addition and subtraction of numbers using standard algorithm, where the digits must be aligned according to place values.

Pre-emptive Pitfalls

Pupils might find addition and subtraction of decimals with regrouping quite challenging as the decimal points might confuse them. Explain that the decimal point is like a separator that separates the whole number and the fraction value. Emphasise that in addition and subtraction of decimals, the method of standard algorithm is the same as the one used for addition and subtraction of numbers, regardless of the position of the decimal point.

Introduction

The standard algorithm can be used when adding and subtracting decimals as well. Reinforce the need to align the digits and the decimal points. Introduce decimal discs and place-value charts to add and subtract decimals. Encourage pupils to use mental strategies to add and subtract (e.g. Let's Learn 5 in Textbook 4 P188 and 193). In Let's Learn 5 (Textbook 4 P188), ask pupils to add 7 hundredths and 4 hundredths which gives 11 hundredths. Explain that just as 2 tens and 5 tens give 7 tens, 2 tenths and 5 tenths give 7 tenths. Estimate the answer to an addition or subtraction of decimals by removing the decimal point. For example, it might be easier for pupils to add 2.6 and 6.78 by adding 260 and 678. This is done by adding a zero to 2.6 to give 2.60 and removing the decimal point of the two decimals. Emphasise the importance of introducing a zero to 2.6 when adding, otherwise the answer might be incorrect.

Problem Solving

Explain using Let's Learn 5 (Textbook 4 P193) that the concept of regrouping involved in the addition and subtraction of decimals is exactly the same as that of regrouping involved in the addition and subtraction of numbers.

Activities

Write the steps in Textbook 4 P189 and 194 on chart paper and put it up on the soft board. Ask pupils to do sums on their mini whiteboard and raise it in the air once done.

Resources

- decimal discs (Activity Handbook 4 P37)
- number discs (Activity Handbook 4 P5)
- place-value chart (Activity Handbook 4 P38)
- mini whiteboard
- markers
- chart paper
- decimal addition and subtraction cards (Activity Handbook 4 P47)

Mathematical Communication Support

In the addition and subtraction of decimals, use terms like 'difference', 'subtraction', 'sum', 'without regrouping' and 'regrouping'. Get pupils to verbalise every step involved when subtracting 7 hundredths from 9 hundredths.

LESSON 3

MULTIPLYING DECIMALS

LEARNING OBJECTIVE

1. Multiply decimals (up to 2 decimal places) by a 1-digit whole number.

LESSON
3

MULTIPLYING DECIMALS

IN

FOCUS

The length of 1 chopstick is 0.2 m.
What is the total length of 4 such chopsticks?

$0.2 + 0.2 + 0.2 + 0.2$

LET'S LEARN

- Multiply 0.2 by 4.

$$\begin{array}{r} 0.2 \\ \times 4 \\ \hline 0.8 \end{array}$$

2 tenths \times 4 = 8 tenths

$0.2 \times 4 = 0.8$

The total length of 4 such chopsticks is 0.8 m.
- Multiply 0.03 by 4.

$$\begin{array}{r} 0.03 \\ \times 4 \\ \hline 0.12 \end{array}$$

3 hundredths \times 4 = 12 hundredths
 12 hundredths = 1 tenth 2 hundredths
 = 0.12

$0.03 \times 4 = 0.12$
- Multiply.

You may use and to help you.

(a) $3 \times 0.2 = 0.6$

(b) $0.4 \times 8 = 3.2$

(c) $0.09 \times 4 = 0.36$

(d) $6 \times 0.07 = 0.42$

OXFORD UNIVERSITY PRESS DECIMALS (II) 196

IN FOCUS

Discuss the problem in the In Focus. Get pupils to write the number equation. Pupils may write a repeated addition equation, direct them to write a multiplication statement (multiply 2 tenths by 4).

LET'S LEARN

Use decimal discs to illustrate the multiplication algorithm of 1-place decimal by a 1 digit number. Focus pupils' attention the alignment of the decimal points. Then, guide pupils to see that 2 tenths \times 4 = 8 tenths.

For Let's Learn 2, get a pupil to illustrate the renaming using decimal discs. Relate the renaming with the exchange of 10 for 1 to the algorithm.

Select pupils to illustrate 3(a) and (c) using number and decimal discs. Then allow pupils to complete 3(b) and (d) on their whiteboard without using the manipulatives. Look out for pupils' errors as teaching points.

Textbook 4 P196

4. Multiply 1.41 by 5.

Step 1 Multiply the hundredths by 5.
1 hundredth \times 5 = 5 hundredths

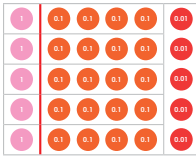

$$\begin{array}{r} 1.41 \\ \times \quad 5 \\ \hline \end{array}$$

Step 2 Multiply the tenths by 5.
4 tenths \times 5 = 20 tenths
20 tenths = 2 ones

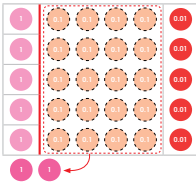

$$\begin{array}{r} 1.41 \\ \times \quad 5 \\ \hline .05 \end{array}$$

Step 3 Multiply the ones by 5.
1 one \times 5 = 5 ones
5 ones + 2 ones = 7 ones

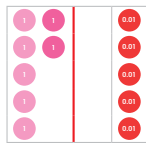

$$\begin{array}{r} 1.41 \\ \times \quad 5 \\ \hline 7.05 \end{array}$$

$1.41 \times 5 = 7.05$

For Let's Learn 4.

Step 1: Illustrate and relate the algorithm step-by-step to the number and decimal discs.

Step 2: Focus pupils' attention on the exchange of 20 tenths for 2 ones and the writing of the renamed digit in the algorithm.

Step 3: Highlight common mistakes that pupils make: adding the renamed numbers before multiplying.

5. Multiply 4.56 by 2.

First, estimate the answer.
 $4.56 \approx 5$
 $5 \times 2 = 10$



$$\begin{array}{r} 4.56 \\ \times \quad 2 \\ \hline 9.12 \end{array}$$

Step 1 Multiply the hundredths by 2.
6 hundredths \times 2 = 12 hundredths
12 hundredths = 1 tenth 2 hundredths

Step 2 Multiply the tenths by 2.
5 tenths \times 2 = 10 tenths
10 tenths + 1 tenth = 11 tenths
11 tenths = 1 one 1 tenth

Step 3 Multiply the ones by 2.
4 ones \times 2 = 8 ones
8 ones + 1 one = 9 ones

$4.56 \times 2 = 9.12$

9.12 is near 10.
The answer is reasonable.



Find the value of 456×2 .
How is your working similar to the working for 4.56×2 ?

Let's Learn 5 features multiplication with two renaming. Guide pupils to estimate the answer first. Then illustrate the formal algorithm step-by-step. Draw special attention to the renaming of hundredths, tenths and ones place.

6. Multiply 8.53 by 3.

$$\begin{array}{r} 8.53 \\ \times 3 \\ \hline \end{array}$$

- Step 1** Multiply the hundredths by 3.
3 hundredths \times 3 = 9 hundredths
- Step 2** Multiply the tenths by 3.
5 tenths \times 3 = 15 tenths
15 tenths = 1 one 5 tenths
- Step 3** Multiply the ones by 3.
8 ones \times 3 = 24 ones
24 ones + 1 one = 25 ones
25 ones = 2 tens 5 ones

$$8.53 \times 3 = 25.59$$

Is your answer reasonable?

7. Multiply.

(a)
$$\begin{array}{r} 2.6 \\ \times 3 \\ \hline 7.8 \end{array}$$

(b)
$$\begin{array}{r} 0.17 \\ \times 4 \\ \hline 0.68 \end{array}$$

(c)
$$\begin{array}{r} 5.32 \\ \times 6 \\ \hline 31.92 \end{array}$$

(d)
$$\begin{array}{r} 47.92 \\ \times 5 \\ \hline 239.60 \end{array}$$

199 CHAPTER 9

OXFORD UNIVERSITY PRESS

Textbook 4 P199

Reinforce the multiplication algorithm using Let's Learn 6. Guide the pupils to fill in the blanks to check their understanding. Check the answer against the estimate for reasonableness.

For Let's Learn 7, allow pupils to work in pairs to check their partner's calculation. Encourage pupils to estimate the answer first.

Work in pairs.

- Write down a decimal number up to 2 decimal places.
- Roll the  and multiply the number shown on the dice with the decimal number that you have written.
- Show the multiplication and get your partner to check your answer.
- Take turns and repeat 1 to 3.

ACTIVITY TIME

What you need:



PRACTICE

1. Multiply.

(a)
$$\begin{array}{r} 0.2 \\ \times 3 \\ \hline 0.6 \end{array}$$

(b)
$$\begin{array}{r} 0.14 \\ \times 2 \\ \hline 0.28 \end{array}$$

(c)
$$\begin{array}{r} 1.5 \\ \times 7 \\ \hline 10.5 \end{array}$$

(d)
$$\begin{array}{r} 0.43 \\ \times 9 \\ \hline 3.87 \end{array}$$

2. Multiply.

Check if your answers are reasonable.

(a) $2.37 \times 2 = 4.74$

(b) $15.48 \times 4 = 61.92$

(c) $8 \times 19.5 = 156$

(d) $6 \times 24.62 = 147.72$

Complete Workbook 4B, Worksheet 3 • Pages 39 – 42

OXFORD UNIVERSITY PRESS

DECIMALS (II) 200

Textbook 4 P200

ACTIVITY TIME

In this activity, pupils will have the opportunity to form decimals of up to 2 decimal places and multiply it by the rolled number.

PRACTICE

Work through the practice questions with pupils. Use mistakes in their algorithms for class discussion to rectify them.

Independent seatwork

Assign pupils to complete Worksheet 3 (Workbook 4B P39 – 42).

1. (a) 1.0
(b) 0.48
(c) 0.40
(d) 0.54
(e) 3.69
(f) 70.07
2. (a) 28.8
(b) 82.8
(c) 124
(d) 86.7
(e) 327.6
3. (a) 8.32
(b) 19.53
(c) 10.08
(d) 69.04
(e) 373.66
(f) 400.72
4. (a) 98.1
(b) 179.92
(c) 352.3

OXFORD
UNIVERSITY PRESS

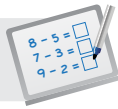
**Specific Learning Focus**

- Multiply decimals (up to 2 decimal places) by a 1-digit whole number.

Suggested Duration

6 periods

Prior Learning

Pupils should be well-versed with multiplication of numbers using multiplication algorithm, where the digits must be aligned according to place values. Point out to pupils that in this lesson, only 1-digit multiplier are dealt with.

Pre-emptive Pitfalls

Although the method of multiplication algorithm for decimals is the same as for whole numbers, the decimal point and its placing could be a bit challenging for some pupils.

Introduction

In Let's Learn 1 (Textbook 4 P196), the steps to solving the question can be verbalised as 2 tenths times 4 is 8 tenths. Explain how the multiplication algorithm is carried out and where the decimal point of the product is placed. Emphasise that since the multiplicand has 1 d.p., the product will also have 1 d.p. Similarly, a multiplicand with 2 d.p. multiplied by a 1-digit whole number multiplier will give a 2-digit product (Let's Learn 4 – 6 in Textbook 4 P197 – 199). In Let's Learn 5, the carrying over (renaming) takes place twice. Emphasise that 6 hundredths times 2 is 12 hundredths which is 1 tenth and 2 hundredths. Then, 5 tenths times 2 plus 1 tenth is 11 tenths. 11 tenths are regrouped to 1 one and 1 tenth.

Problem Solving

Mathematical steps need to be verbalised and step-by-step solution to sums should be carried out on the board. The solution to Let's Learn 5 (Textbook 4 P198) can be written on chart paper, where each step is written in different coloured markers, which can then be put up on the class soft board.

Activities

In 'Activity Time' (Textbook 4 P200), get pupils to work in pairs to make their own sums by rolling a die. Peer checking will help them grasp this concept.

Resources

- number discs (Activity Handbook 4 P5)
- decimal discs (Activity Handbook 4 P37)
- dice
- mini whiteboard
- markers

Mathematical Communication Support

Explain all steps using mathematical terms like 'times', 'equations' and 'decimal places'. Emphasise that when a multiplicand with 1 d.p. is multiplied by a 1-digit whole number multiplier, the product would have 1 d.p. Similarly, a multiplicand with 2 d.p. multiplied by a 1-digit whole number multiplier would give a product with 2 d.p.

LEARNING OBJECTIVE

1. Divide decimals (up to 2 decimal places) by a 1-digit whole number.

DIVIDING DECIMALS

IN FOCUS

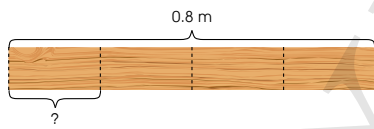

Tom cuts a plank of wood of length 0.8 m into 4 parts of equal length. How long is each part?

LET'S LEARN

1. Divide 0.8 by 4.

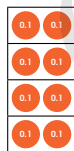
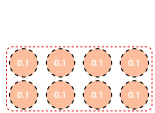

$$\begin{array}{r} 0.2 \\ 4 \overline{) 0.8} \\ \underline{0.8} \\ 0 \end{array}$$

$$0.8 \div 4 = 0.2$$

Each part of the plank is 0.2 m long.

8 tenths \div 4 = 2 tenths



IN FOCUS

Review the division concept by posing a similar problem using whole numbers. Then lead pupils to see that they are looking at a similar question in the In Focus. Get pupils to write the division statement (divide 8 tenths by 4).

LET'S LEARN

Illustrate $0.8 \div 4$ by showing 8 tenths discs and then group them into 4 equal groups. Lead pupils to see that eight tenths divided by 4 gives 2 tenths. Show pupils the algorithm and emphasise the importance of alignment (digits and decimal point). Relate the quotient to the decimal discs.

2. Divide 0.21 by 3.

We cannot divide 2 tenths into 3 equal groups.
Rename 2 tenths 1 hundredth as 21 hundredths.

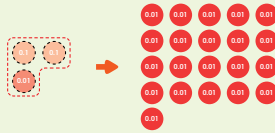

2 tenths = 20 hundredths
20 hundredths + 1 hundredth
= 21 hundredths

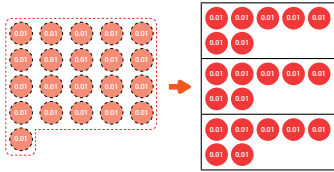

$$0.21 \div 3 = 0.07$$

21 hundredths \div 3
= 7 hundredths

What do you get
when you divide 21 by 3?



$$\begin{array}{r} 0.07 \\ 3 \overline{) 0.21} \\ \underline{0.21} \\ 0 \end{array}$$

OXFORD
UNIVERSITY PRESS

DECIMALS (II) 202

Textbook 4 P202

3. Divide.

You may use to help you.

(a) $0.9 \div 3 = 0.3$

(b) $0.8 \div 2 = 0.4$

(c) $0.36 \div 4 = 0.09$

(d) $0.27 \div 3 = 0.09$

4. Divide 3.12 by 3.

Step 1 Divide the ones by 3.

$3 \div 3 = 1$
 $3.00 \div 3 = 1.00$

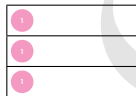

3 ones \div 3 = 1 one
Put in the decimal point.



We cannot divide 1 tenth into 3 equal groups.
Rename 1 tenth 2 hundredths as 12 hundredths.



1 tenth = 10 hundredths
10 hundredths + 2 hundredths
= 12 hundredths



$$\begin{array}{r} 1.0 \\ 3 \overline{) 3.12} \\ \underline{3} \\ 12 \\ \underline{12} \\ 0 \end{array}$$

203 CHAPTER 9

OXFORD
UNIVERSITY PRESS

Textbook 4 P203

Let's Learn 2 features the division of a 2-place decimal by a 1-digit number with one renaming. The focus of the example is on the renaming of 2 tenths since it cannot be divided into 3 equal groups.

First, the teacher will read the division equation to the class (Divide 21 hundredths by 3). Show 21 and get a pupil to divide them into 3 equal groups with 7 in each group. Get pupils to recite, 21 hundredths divided by 3 is 7 hundredths.

Write the long division algorithm and illustrate each step with decimal discs. When renaming the 2 tenths,

illustrate the exchanging of 2 for 20 .

Highlight the placement of the decimal point and the insertion of zeros as a place-holder in the one and tenth places of the quotient.

Illustrate the long division algorithm for 3(a) and (c) using decimal discs. Then allow pupils to work in pairs for 3(b) and (d).

Get pupils to estimate the answer for Let's Learn 4 before illustrating the long division algorithm step-by-step.

Step 1: Highlight the writing of zero as a place-holder in the tenth place of the quotient since 1 tenth cannot be divided into 3 equal groups. Illustrate the exchange of

1 for 10 . There are 12 now.

Step 2 Divide the hundredths by 3.

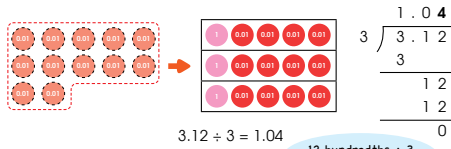

$$3.12 \div 3 = 1.04$$

12 hundredths \div 3 = 4 hundredths

1.04 is near 1.00.
The answer is reasonable.



5. What do we get when we divide 5 by 4?

Step 1 Divide the ones by 4.

5 ones \div 4 = 1 one with remainder 1 one

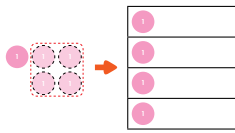

$$4 \overline{) 5.000}$$

Write the digit 1 in the ones column and put in the decimal point.



Rename 1 one as 10 tenths.

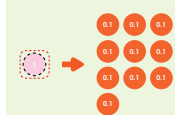

$$4 \overline{) 5.000}$$

OXFORD UNIVERSITY PRESS

DECIMALS (II) 204

Textbook 4 P204

Step 2: Divide 12 hundredths by 3. Highlight the writing of the quotient 4 and the remainder 0 at the hundredths column.

Let's Learn 5 features the division of a whole number by a 1-digit whole number. Illustrate the division algorithm step-by-step with the aid of number and decimal discs. Highlight:

- The inclusion of decimal points in the quotient and the given number.
- The insertion of zeros as place holders for the respective place value columns to further divide any remainder.
- The renaming of 1 one as 10 tenths.

Step 2 Divide the tenths by 4.

10 tenths \div 4 = 2 tenths with remainder 2 tenths

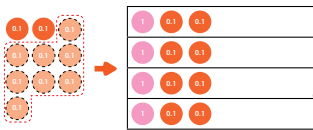

$$4 \overline{) 5.200}$$

Write the digit 2 in the tenths column.



Rename 2 tenths as 20 hundredths.

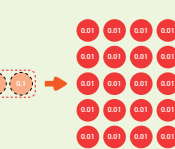

$$4 \overline{) 5.200}$$

205 CHAPTER 9

OXFORD UNIVERSITY PRESS

Textbook 4 P205

Highlight:

- The renaming of the remainder 2 tenths as 20 hundredths.

Step 3 Divide the hundredths by 4.
20 hundredths \div 4 = 5 hundredths

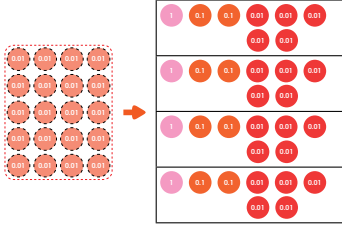

$$5 \div 4 = 1.25$$

$$\begin{array}{r} 1.25 \\ 4 \overline{) 5.00} \\ \underline{4} \\ 10 \\ \underline{8} \\ 20 \\ \underline{20} \\ 0 \end{array}$$

Write the digit 5 in the hundredths column.



6. Divide 8 by 5.
Express your answer in decimal form.

Step 1 Divide the ones by 5.
8 ones \div 5 = 1 one with remainder 3 ones

$$\begin{array}{r} 1. \\ 5 \overline{) 8.0} \\ \underline{5} \\ 3 \end{array}$$

Put in the decimal point after the ones column.



Step 2 Rename 3 ones as 30 tenths.
Divide the tenths by 5.
30 tenths \div 5 = 6 tenths

$$\begin{array}{r} 1.6 \\ 5 \overline{) 8.0} \\ \underline{5} \\ 30 \\ \underline{30} \\ 0 \end{array}$$

$$8 \div 5 = 1.6$$

OXFORD
UNIVERSITY PRESS

DECIMALS (II) 206

Textbook 4 P206

Reinforce the division algorithm learnt in Let's Learn 5 with a simpler example (Let's Learn 6) without the use of number discs.

7. Divide.

(a) $9 \div 4 = 2.25$

(b) $3 \div 5 = 0.6$

8. Divide 4.1 by 4.
Give your answer to 2 decimal places.

Step 1 Divide the ones by 4.

First, estimate the answer.
 $4.1 \approx 4$
 $4.00 \div 4 = 1.00$

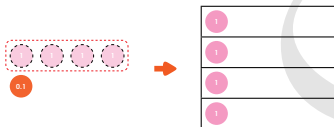

$$4 \text{ ones} \div 4 = 1 \text{ one}$$



We cannot divide 1 tenth into 4 equal groups.
Rename 1 tenth as 10 hundredths.

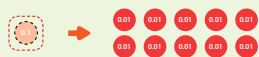

$$\begin{array}{r} 1.0 \\ 4 \overline{) 4.100} \\ \underline{4} \\ 010 \\ \underline{000} \\ 0 \end{array}$$

$$1 \text{ tenth} = 10 \text{ hundredths}$$



207 CHAPTER 9

OXFORD
UNIVERSITY PRESS

Textbook 4 P207

For Let's Learn 7, select pupils to work out the sum on the board. Identify mistakes and rectify them with the class.

Reinforce the division algorithm with Let's Learn 8. Get pupils to estimate the answer first. Allow pupils to work in groups to present each step the teacher illustrates using number and decimal discs. Select representatives from each group to fill in the blanks.

Check answer against the estimate for reasonableness.

Step 2 Divide the hundredths by 4.

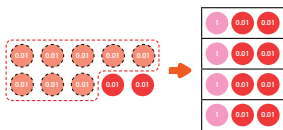

10 hundredths \div 4
= 2 hundredths with
remainder 2 hundredths

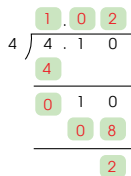

We cannot divide 2 hundredths into 4 equal groups.
Rename 2 hundredths as 20 thousandths.

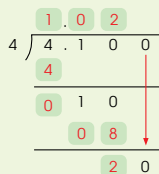

OXFORD UNIVERSITY PRESS

DECIMALS (II) 208

Textbook 4 P208

Step 3 Divide the thousandths by 4.

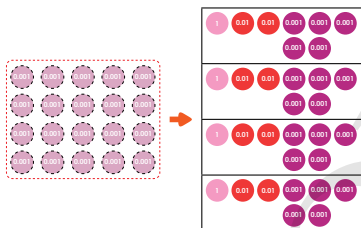

$$4.1 \div 4 = 1.025 \\ = 1.03 \text{ (to 2 decimal places)}$$

Is your answer reasonable?



9. Find the value of $5 \div 3$.
Give your answer correct to 1 decimal place.

$$5 \div 3 = 1.7 \text{ (to 1 decimal place)}$$



Divide to 2 decimal places.
Then round the answer to
1 decimal place.

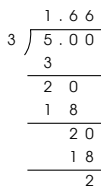

209 CHAPTER 9

OXFORD UNIVERSITY PRESS

Textbook 4 P209

Let's Learn 9 is an example of a division sum that has a recurring decimal or repeating decimal quotient. Teacher may ask pupils to continue the division to highlight the effect. Lead pupils to see that to give the answer correct to 1 decimal place, we need to divide to 2 decimal places.

10. Find the value of each of the following.
Give your answers correct to 2 decimal places.

- (a) $0.58 \div 3 = 0.19$ (b) $3.67 \div 6 = 0.61$
 (c) $1.3 \div 7 = 0.19$ (d) $7 \div 9 = 0.78$



ACTIVITY  TIME

Work in pairs.

$1 \div 2 = ?$

What you need:



- Use  to show how you divide.
- Get your partner to show the working.
- Compare your answers.
Do you get the same answer?
- Use  and  to show the division.

- (a) $1 \div 3 = 0.33$ (b) $1 \div 4 = 0.25$
 (c) $1 \div 5 = 0.20$ (d) $1 \div 6 = 0.17$
 (e) $1 \div 7 = 0.14$ (f) $1 \div 8 = 0.13$

Textbook 4 P210

Get pupils to compete for accuracy to complete the four sums in Let's Learn 10. For each sum done correctly, the pupil gets 2 points. The first pupil who complete the sums with the highest score (8) wins.

ACTIVITY  TIME

The activity allows pupils to work together to correct each other mistakes and arrive at the same correct answer. They will also recognise that some of the quotients are recurring decimals.

1. Divide.

- (a) $4 \overline{) 0.04}$ (b) $4 \overline{) 1.6}$
 (c) $5 \overline{) 0.52}$ (d) $3 \overline{) 1.23}$
 (e) $6 \overline{) 5.41}$ (f) $5 \overline{) 8.71}$

2. Divide.
Check if your answers are reasonable.

- (a) $2.18 \div 2 = 1.09$ (b) $25.08 \div 6 = 4.18$
 (c) $37.45 \div 7 = 5.35$ (d) $71.85 \div 5 = 14.37$

3. Divide.
Give your answers correct to 1 decimal place.

- (a) $7 \div 3 = 2.3$ (b) $19 \div 6 = 3.2$
 (c) $2.9 \div 5 = 0.6$ (d) $54.36 \div 9 = 6.0$

Textbook 4 P211

PRACTICE 

Pupils to work in groups. Then work through the practice questions with the class.

Independent seatwork

Assign pupils to complete Worksheet 4 (Workbook 4B P43 – 48).

1. (a) 0.2
(b) 0.5
(c) 0.6
(d) 0.7
(e) 0.02
(f) 0.05
(g) 0.05
(h) 0.09

2. (a) 19
(b) 7.73
(c) 26.7
(d) 4.29
(e) 2.4
(f) 8.25

3. (a) 3.33
(b) 0.61 (to 2 decimal places)
(c) 2.78 (to 2 decimal places)
(d) 5.11 (to 2 decimal places)

4. (a) 2.4
(b) 5.1 (to 1 decimal place)
(c) 8.4 (to 1 decimal place)
(d) 7.6 (to 1 decimal place)
(e) 9.5 (to 1 decimal place)

OXFORD
UNIVERSITY PRESS

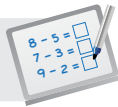
**Specific Learning Focus**

- Divide decimals (up to 2 decimal places) by a 1-digit whole number.

Suggested Duration

6 periods

Prior Learning

Pupils should be well-versed with the division algorithm, where the digits must be aligned according to place values.

Pre-emptive Pitfalls

Pupils might face difficulty when the division of a number gives a remainder. Doing sums on the board and verbalising each step will help them grasp the concept of division of decimals easily.

Introduction

In Let's Learn 4 (Textbook 4 P203), point out that we cannot divide 1 tenth by 3. Reinforce that in this case, renaming is required, and '0' is to be placed in the tenths place of the quotient. Remind pupils that in division algorithm, the digits and decimal points must be aligned.

Problem Solving

Emphasise that if a number is not large enough to be divided into equal groups, renaming is required.

Activities

In 'Activity Time' (Textbook 4 P210), get pupils to work in pairs. Provide each pair with decimal discs, mini whiteboard and markers, and ask them to work out their divisions on their mini whiteboard.

Resources

- mini whiteboard
- markers
- number discs (Activity Handbook 4 P5)
- decimal discs (Activity Handbook 4 P37)
- division algorithm cards (Activity Handbook 4 P48)

Mathematical Communication Support

Verbalise the steps in the division algorithm as the sums in 'Let's Learn' (Textbook 4 P201 – 209) are done on the board. Highlight the alignment of the digits and decimal points. Once the pupils are well-versed with the concept and method, elicit individual responses for each step.

SOLVING WORD PROBLEMS

LEARNING OBJECTIVES

1. Solve up to 2-step word problems involving the four operations.
2. Round answers to a specified degree of accuracy.

*Note to teacher:

Refer to the 4-step approach to problem solving template (Activity Handbook 4 P49) which can be used for all such lessons involving problem solving.

SOLVING WORD PROBLEMS

LESSON

5

IN
FOCUS

Mrs Lim had 28 m of cloth.
She used 3.6 m of the cloth to sew a pair of trousers.
She used the remaining cloth to sew 4 long gowns of the same design.
What was the length of cloth Mrs Lim used to sew each gown?

LET'S LEARN

1. **Step 1** Understand the problem.

What do we need to find?

Look for information to help you understand the problem.

What was the length of cloth Mrs Lim had at first?
Was there any cloth left over after Mrs Lim sewed the pair of trousers and the gowns?

OXFORD UNIVERSITY PRESS
DECIMALS (II) 212

IN FOCUS

Invite pupils to talk about the picture and the problem. Ask pupils what information they can gather.

LET'S LEARN

Using Let's Learn 1, model the stages of problem solving to guide pupils.

Step 1: Understand the problem.

- Give pupils time to read the problem silently before reading it aloud with the class.
- Get pupils to underline the key elements. Set pupils thinking by asking:
What do we know?
What does the question want us to find?
What do we need to find first?

Step 2 Think of a plan and carry it out.

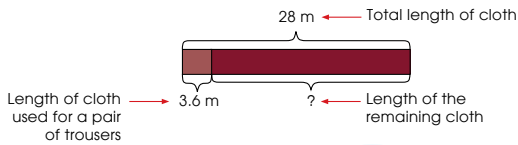

$$28 - 3.6 = 24.4$$

Why do we find the length of the remaining cloth first?



The length of the remaining cloth was 24.4 m.

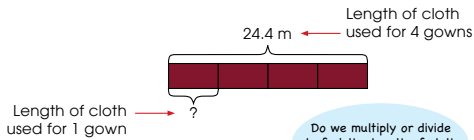

$$24.4 \div 4 = 6.1$$

Do we multiply or divide to find the length of cloth used to sew each gown?



Mrs Lim used 6.1 m of cloth to sew each gown.

Step 3 Check your answer.

You can do this by checking the reasonableness of your answers. Think of other ways you can check your answer.



Step 2: Think of a plan and carry it out.

- Ask pupils what is the best way to present the key elements.
- Draw a model for each step. Label the known and unknown.
What model should be drawn first?
How can we use each model to find the next step?
- Examine each model.
Which operation should we use?
- Write the number equation for each step and solve it.

Step 3: Check your answer.

- Look back and check if your answer is reasonable.

2. Raju and Kate have a total of \$6.90. Raju has \$1.80 more than Kate. How much money does Kate have?

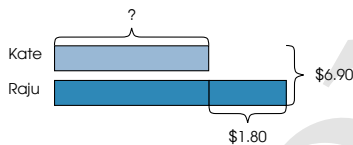

$$2 \text{ units} = \$6.90 - \$1.80 = \$5.10$$

$$1 \text{ unit} = \$5.10 \div 2 = \$2.55$$

Kate has \$ 2.55.

3. Ann bought 10 ℓ of orange juice. After filling up 6 identical bottles with orange juice, she had 2.5 ℓ of orange juice left. Find the amount of orange juice in each bottle.

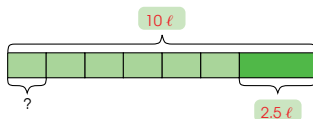

$$10 \ell - 2.5 \ell = 7.5 \ell$$

The total amount of orange juice in 6 bottles was 7.5 ℓ.

$$7.5 \ell \div 6 = 1.25 \ell$$

The amount of orange juice in each bottle was 1.25 ℓ.

Repeat the same process for Let's Learn 2.

For Let's Learn 3 and 4, allow pupils to work in pairs. One of pupils will solve the question while the partner will act as the facilitator, asking questions and prompting the other.

4. Meiling bought 4 blouses and 1 skirt. Each blouse cost \$18.30 and each skirt cost \$21.25. How much did Meiling pay for all the items? Give your answer correct to the nearest dollar.

$$\$ 18.30 \times 4 = \$ 73.20$$

4 blouses cost \$ 73.20 .





$$\$ 73.20 + \$ 21.25 = \$ 94.45$$

$$= \$ 94 \text{ (to the nearest dollar)}$$

Meiling paid about \$ 94 for all the items.

ACTIVITY TIME

Work in groups of 4.

- 1 Read a supermarket advertisement from . What you need:   
- 2 Choose two items shown in the advertisement.
- 3 Make a word problem using the two items.
- 4 Show your word problem to your classmates. Get them to solve the problem and to explain their method.
- 5 Take turns and repeat 2 to 4.

215 CHAPTER 9

OXFORD UNIVERSITY PRESS

Textbook 4 P215

Remind pupils to reverse their roles for Let's Learn 4.

ACTIVITY TIME

The activity allows pupils to use real-world context to create word problems. Provide pupils with supermarket advertisements from newspapers or websites. Select pupils to present their word problems and solutions.

Solve.
Check if your answers are reasonable.

PRACTICE

1. Sam has 7 packets of flour. $1.05 \text{ kg} \times 7 = 7.35 \text{ kg}$
Each packet contains 1.05 kg of flour.
How much flour does Sam have in total?
2. The cost of a red pen is \$2.45.
A blue pen costs \$0.80 more than the red pen. $\$2.45 + \$0.80 = \$3.25$
What is the cost of 5 such blue pens? $\$3.25 \times 5 = \16.25
3. Mrs Ali bought 3 bottles of detergent. $3 \times 3.5 \text{ l} = 10.5 \text{ l}$
Each bottle contained 3.5 l of detergent. $10.5 \text{ l} \div 6 = 1.75 \text{ l}$
The detergent was poured equally into 6 containers.
What was the volume of detergent poured into each container?

Complete Workbook 4B, Worksheet 5 • Pages 49 – 53

MIND WORKOUT

Solve.

$$\begin{array}{r} 3.7 \\ \times 3 \\ \hline 11.1 \end{array}$$

$$\begin{array}{r} 3.7 \\ \times 6 \\ \hline 22.2 \end{array}$$

$$\begin{array}{r} 3.7 \\ \times 9 \\ \hline 33.3 \end{array}$$

Use the pattern to find the missing numbers.

$$3.7 \times 3 \times 1 = 11.1$$

$$3.7 \times 3 \times 2 = 22.2$$

$$3.7 \times 3 \times 3 = 33.3$$

$$3.7 \times 3 \times 4 = 44.4$$

What comes next in the pattern?



OXFORD UNIVERSITY PRESS

DECIMALS (II) 216

Textbook 4 P216

PRACTICE

Allow pupils to work in pairs. Follow up by working through the solution, modeling the stages of problem solving. For more practice, select questions from Worksheet 5 to solve with pupils in the class.

Independent seatwork

Assign pupils to complete Worksheet 5 (Workbook 4B P49 – 53).

1. $20.15 \text{ m} \div 5 = 4.03 \text{ m}$
Each piece is 4.03 m.
2. $2.1 \text{ l} - 1.75 \text{ l} = 0.35 \text{ l}$
The capacity of the mug is 0.35 l.
3. (a) $\$13.65 \times 3 = \40.95
Priya spent \$40.95.
(b) $\$40.95 + \$13.65 = \$54.60$
They spent \$54.60 altogether.
4. (a) $\$50 - \$35.30 = \$14.70$
She received \$14.70 in change.
(b) $\$14.70 \div 3 = \4.90
1 bottle of detergent cost \$4.90.
5. $21.48 \text{ m} \div 4 = 5.37 \text{ m}$
 $21.48 \text{ m} + 5.37 \text{ m} = 26.85 \text{ m}$
The total length of Rope A and Rope B is 26.58 m.
6. $\$98 + \$18.20 = \$116.20$
 $\$116.20 \div 2 = \58.10
The cost of the necklace is \$58.10.
7. $\$3.95 \times 7 = \27.65
 $\$27.65 - \$21.40 = \$6.25$
He needs \$6.25 more.
8. $2.5 \text{ kg} \times 6 = 15 \text{ kg}$
 $15 \text{ kg} \div 8 = 1.875 \text{ kg}$
 $\approx 1.9 \text{ kg}$
He used 1.9 kg of sugar for each tray of muffins.
- *9 $\$8.20 - \$2.50 = \$5.70$
 $\$5.70 \div 3 = \1.90
Nora had \$1.90 left.

PROBLEM SOLVING, MATHS JOURNAL AND PUPIL REVIEW

PRACTICE 

Solve.
Check if your answers are reasonable.

- Sam has 7 packets of flour. $1.05 \text{ kg} \times 7 = 7.35 \text{ kg}$
Each packet contains 1.05 kg of flour.
How much flour does Sam have in total?
- The cost of a red pen is \$2.45.
A blue pen costs \$0.80 more than the red pen. $\$2.45 + \$0.80 = \$3.25$
What is the cost of 5 such blue pens? $\$3.25 \times 5 = \16.25
- Mrs Ali bought 3 bottles of detergent. $3 \times 3.5 \text{ l} = 10.5 \text{ l}$
Each bottle contained 3.5 l of detergent. $10.5 \text{ l} \div 6 = 1.75 \text{ l}$
The detergent was poured equally into 6 containers.
What was the volume of detergent poured into each container?

 Complete Workbook 4B, Worksheet 5 • Pages 49 - 53

 **MIND WORKOUT**

Solve.

$\begin{array}{r} 3.7 \\ \times 3 \\ \hline 11.1 \end{array}$	$\begin{array}{r} 3.7 \\ \times 6 \\ \hline 22.2 \end{array}$	$\begin{array}{r} 3.7 \\ \times 9 \\ \hline 33.3 \end{array}$
---	---	---

Use the pattern to find the missing numbers.

$3.7 \times 3 \times 1 = 11.1$
 $3.7 \times 3 \times 2 = 22.2$
 $3.7 \times 3 \times 3 = 33.3$
 $3.7 \times 3 \times 4 = 44.4$

 What comes next in the pattern?

OXFORD UNIVERSITY PRESS

DECIMALS (II) 216



MIND WORKOUT

Besides applying their skills to multiply decimals by a 1-digit number, this problem stimulates pupils to look for a pattern and find the missing number.

Textbook 4 P216



Mind Workout

Date: _____

Ahmad and Kate had the same amount of money. Kate's mother gave her \$35 and Ahmad spent \$12.80. Kate then had 3 times as much money as Ahmad. How much money did Ahmad have in the end?

$$\begin{aligned} \$35 + \$12.80 &= \$47.80 \\ \$47.80 \div 2 &= \$23.90 \end{aligned}$$

Ahmad had \$23.90 in the end.

Draw a model to help you.



Workbook 4B P54



Mind Workout

Use before-after comparison model to solve the problem.

MATHS JOURNAL

Xinyi needs to buy the items on the shopping list.

Shopping list

1. Toothpaste	\$10.05
2. Toothbrush	\$6.90
3. Oranges	\$3.95
4. Broccoli	\$3.15
5. Fish	\$4.80
6. Ice cream	\$6.10

She receives \$40 from her mother. How can Xinyi use estimation to make sure that she has enough money to buy all the items in the list?

I know how to...

- add up to 2 decimal places.
- subtract up to 2 decimal places.
- multiply decimals by a 1-digit whole number.
- divide decimals by a 1-digit whole number.
- divide a whole number by a whole number and express the answer as a decimal.
- solve word problems involving decimals.

SELF-CHECK



Textbook 4 P217

MATHS JOURNAL

The task provides learning experiences for pupils to make estimates in the use of money. Pupils can round to the nearest dollar or nearest 10 cents to evaluate which is a better estimate to avoid not having enough money to pay for the purchases.

Before the pupils do the self-check, review the important concepts once more by asking for examples learnt for each objective.

The self-check can be done after pupils have completed **Review 9** (Workbook 4B P55 – 60).

SELF-CHECK



1. (a) 10.06
(b) 19
(c) 38.12
2. (a) 4.03
(b) 1.59
(c) 11.59
3. (a) 38
(b) 60.3
(c) 68.64
4. (a) 0.82
(b) 4.52
(c) 31.75
5. (a) $\$1.95 + \$1.50 = \$3.45$
 $\$3.45 - \$3.20 = \$0.25$
He saved \$0.25.
(b) $\$1.95 \times 2 = \3.90
 $\$3.90 + \$0.89 = \$4.79$
They spent \$4.79 altogether.
6. $\$5.85 + \$3.55 = \$9.40$
 $\$9.40 \div 4 = \2.35
Each of them had to pay \$2.35.
7. $6.2 \ell \div 4 = 1.55 \ell$
 $1.55 \ell \times 5 = 7.75 \ell$
He had 7.75 ℓ of cooking oil in the end.

OXFORD
UNIVERSITY PRESS

1. (a) 0.245
 (b) 0.637
 (c) 2.53
 (d) 5.069
2. (a) 2.16, 2.28, 2.42
 (b) 6.1, 6.115, 6.124
3. (a) 3.5
 (b) 2.67
 (c) 3.14
 (d) 6.7
 (e) 3.8
 (f) 8.025
4. (a) 9
 (b) 4
 (c) 8
 (d) 1000
5. (a) smaller than
 (b) greater than
 (c) equal to
 (d) smaller than
6. (a) 6.025, 6.2, 6.205, 6.25
 (b) 5.9, 5.39, 5.309, 5.039
7. (a) 97.03
 (b) 64.18
 (c) 4.46
 (d) 0.94
8. (a) 19.9
 (b) 0.6
9. (a) $2\frac{7}{20}$
 (b) $5\frac{7}{20}$
 (c) $3\frac{9}{125}$
 (d) $4\frac{11}{20}$
10. (a) 0.48
 (b) 3.8
 (c) 2.85
 (d) 5.74
 (e) 8.56
 (f) 10.33

OXFORD
 UNIVERSITY PRESS

1. (a) 31.2
(b) 51.93
(c) 80.04
2. (a) 45.9
(b) 1.44
(c) 2.35
3. (a) 64.5
(b) 290.2
(c) 2.35
(d) 7.19
4. (a) 0.36
(b) 1.57 (to 2 decimal places)
(c) 8.50 (to 2 decimal places)
5. $2.65 \ell \times 5 = 13.25 \ell$
The capacity of the tank is 13.25 ℓ .
6. $21.48 \text{ m} \div 4 = 5.37 \text{ m}$
The length of the red ribbon is 5.37 m.
7. (a) $33 \text{ m} - 5.5 \text{ m} = 27.5 \text{ m}$
The length of the remaining piece of cloth is 27.5 m.
(b) $27.5 \text{ m} \div 8 = 3.4375 \text{ m}$
 $\approx 3.44 \text{ m}$
The length of each piece is 3.44 m.
8. $\$8.35 - \$1.85 = \$6.50$
 $\$6.50 \times 9 = \58.50
Mr Tan's brother will earn \$58.50.
9. $\$38.50 - \$3.70 = \$34.80$
 $\$34.80 \div 3 = \11.60
The cost of 1 kg of prawns is \$11.60.
10. $0.42 \ell \div 6 = 0.07 \ell$
 $0.07 \ell \times 8 = 0.56 \ell$
They measured out 0.56 ℓ of water altogether.

AREA AND PERIMETER

CHAPTER 10

Area and Perimeter CHAPTER **10**

Each pupil is given a wire of equal length to make squares.
How can the pupils find the length of one side of each square?

PERIMETER OF SQUARES AND RECTANGLES LESSON **1**

IN FOCUS

Tom bent a piece of wire into a square.
The wire used was 20 cm long.
What is the length of the square?

OXFORD UNIVERSITY PRESS

AREA AND PERIMETER **218**

Textbook 4 P218

Related Resources

NSPM Textbook 4 (P218 – 234)
NSPM Workbook 4B (P75 – 100)

Materials

Magnetic strips, coloured paper, square grid paper, scissors, ruler, markers, mini whiteboard, squares and rectangles

Lesson

- Lesson 1 Perimeter of Squares and Rectangles
 - Lesson 2 Area of Squares and Rectangles
 - Lesson 3 Area and Perimeter of Composite Figures
 - Lesson 4 More on Area and Perimeter
- Problem Solving, Maths Journal and Pupil Review

INTRODUCTION

In Grade Three, pupils were introduced to the concept of area and perimeter of plane figures drawn on square grids. In Grade Four, these concepts will be expanded to include the use of formulae to calculate area and perimeter of squares, rectangles and figures made of squares and rectangles (composite figures). In addition, pupils are required to find unknown dimension(s) of a shape given the other dimension and its area/perimeter. Problems will feature real-life situations, for example area/perimeter of path around rectangular garden. Learning experiences include making composite figures using cutouts of squares and rectangles. This help pupils visualise how the figure can be partitioned into rectangles and squares.

LESSON

1

PERIMETER OF SQUARES AND RECTANGLES

LEARNING OBJECTIVES

1. Find the length of a square given its perimeter.
2. Find one dimension of a rectangle given the other dimension and its perimeter.

Area and Perimeter

CHAPTER 10

Each pupil is given a wire of equal length to make squares.
How can the pupils find the length of one side of each square?

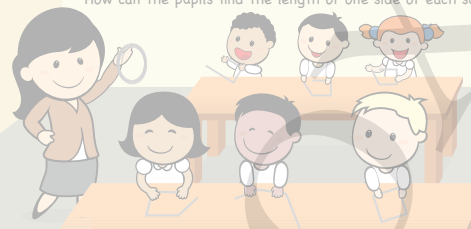

PERIMETER OF SQUARES AND RECTANGLES

LESSON 1

IN  FOCUS



Tom bent a piece of wire into a square.
The wire used was 20 cm long.
What is the length of the square?

OXFORD UNIVERSITY PRESS

AREA AND PERIMETER 218

Textbook 4 P218

IN  FOCUS

Pose the question in the In Focus to the pupils. Elicit from pupils how they can find the sides of the square. Then guide pupils to see that the length of the wire forms the perimeter of the square.

LET'S LEARN

1. The perimeter of the square is 20 cm.

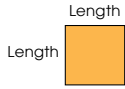

$$\begin{aligned} \text{Perimeter} &= 20 \text{ cm} \\ \text{Length} &= 20 \div 4 \\ &= 5 \text{ cm} \end{aligned}$$

Recall that the perimeter of a square is made up of 4 sides of equal length.



2. The perimeter of the square is 40 m.



$$\begin{aligned} \text{Length} &= 40 \div 4 \\ &= 10 \text{ m} \end{aligned}$$

Length of a square = Perimeter \div 4



3. The perimeter of a rectangle is 28 cm. Its breadth is 4 cm long. What is the length of the rectangle?

Method 1

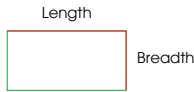

$$\begin{aligned} (\text{Length} + \text{Breadth}) + (\text{Length} + \text{Breadth}) &= 28 \text{ cm} \\ (\text{Length} + \text{Breadth}) &= 28 \div 2 \\ &= 14 \text{ cm} \\ \text{Breadth} &= 4 \text{ cm} \\ \text{Length} &= 14 - 4 \\ &= 10 \text{ cm} \end{aligned}$$

Textbook 4 P219

LET'S LEARN

Review with pupils the properties of a square and also the concept of perimeter. Guide pupils to see that the sum of the four sides gives the perimeter of the square. Hence to find each side, they will divide the perimeter (length of the wire) by 4.

Allow pupils to work on Let's Learn 2 before going through with the class.

For Let's Learn 3, review the concept of perimeter of rectangle. Lead pupils to see that there are two ways to solve the problem. Use magnetic strips to illustrate if necessary.

Method 1

Group length and breadth together (Perimeter = (Length + Breadth) + (Length + Breadth)). Guide pupils to see that a group of one length and one breadth is equal to half the perimeter.

Method 2

Group the opposite sides together (Perimeter = (Length + Length) + (Breadth + Breadth)). Common mistakes among pupils using this method:

- Subtracting only one breadth from the perimeter.
- Taking the total of the two lengths as the final answer.

Allow pupils to work on Let's Learn 4 before working through the solution. Encourage pupils to work out the answer using the two methods learnt in Let's Learn 3.

Method 2

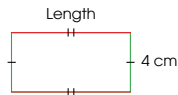

$$\begin{aligned} \text{Breadth} &= 4 \text{ cm} \\ \text{Length} + \text{Length} &= 28 - 4 - 4 \\ &= 20 \text{ cm} \\ \text{Length} &= 20 \div 2 \\ &= 10 \text{ cm} \end{aligned}$$

4. The perimeter of the rectangle is 32 m. Its length is 10 m. Find the breadth of the rectangle.



The breadth of the rectangle is 6 m.

Are there other ways of finding the breadth?



Textbook 4 P220



1. The perimeters of some squares are given.
Find the length of one side of each square.

Perimeter	Length
48 cm	12 cm
32 cm	8 cm
52 m	13 m
120 m	30 m

2. Find the length or breadth of each rectangle.

(a) 24 cm

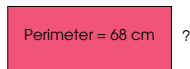

Breadth = 10 cm

(b) 40 m

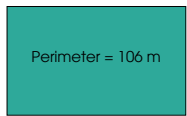

Breadth = 13 m

(c) ?

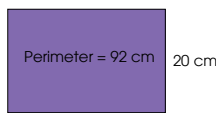

Length = 26 cm

(d) ?

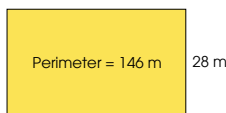

Length = 45 m

Complete Workbook 4B, Worksheet 1 • Pages 75 – 78

Textbook 4 P221



Work with pupils on the practice questions.

For better understanding, select items from **Worksheet 1** and work these out with the pupils.

Independent seatwork

Assign pupils to complete Worksheet 1 (Workbook 4B P75 – 78).

Answers Worksheet 1 (Workbook 4B P75 – 78)

1. $3 \times 4 = 12$

The perimeter of the square is 12 cm.

2. $48 \div 4 = 12$

The length of the square is 12 cm.

3. $8 + 3 + 8 + 3 = 22$

The perimeter of the rectangle is 22 cm.

4. $28 - 5 - 5 = 18$

$18 \div 2 = 9$

The length of the rectangle is 9 cm.

5. (a) $92 \div 4 = 23$

Length = 23 cm

(b) $72 - 6 - 6 = 60$

$60 \div 2 = 30$

Length = 30 cm

(c) $46 - 13 - 13 = 20$

$20 \div 2 = 10$

Breadth = 10 cm

(d) $62 \div 4 = 15.5$

Length = 15.5 m

**Specific Learning Focus**

- Find the length of a square given its perimeter.
- Find one dimension of a rectangle given the other dimension and its perimeter.

Suggested Duration

4 periods

Prior Learning

Area and perimeter of squares and rectangles were introduced to pupils in Grade 3. In Grade 4, this chapter introduces the formulae for area and perimeter of squares and rectangles using the dimensions of squares and rectangles.

Pre-emptive Pitfalls

Area and perimeter of squares and rectangles were introduced to pupils in Grade 3. In Grade 4, this chapter introduces the formulae for area and perimeter of squares and rectangles using the dimensions of squares and rectangles.

Introduction

Refer to the chapter opener (Textbook 4 P218) and discuss with pupils. Bring to class a 20-cm yarn or wire and elicit responses for finding the length of one side of each square. Encourage multiple strategies by telling pupils that 20 cm is the perimeter of the square and not the area. The property of a square – a square has 4 sides of equal length, will help pupils come to the conclusion that 20 cm divided by 4 will give the length of each side of the square, which is 5 cm. Introduce the formulae of the perimeter of a square and a rectangle as:

- Perimeter of a square = $l + l + l + l = 4l$
- Perimeter of a rectangle = $(l + b) + (l + b) = 2l + 2b$

Problem Solving

In Let's Learn 3 (Textbook 4 P219), the perimeter and breadth of the rectangle are given, and the length is to be found. Emphasise the fact that the perimeter of a rectangle is the sum of two lengths and two breadths, and hence subtracting two breadths from the perimeter would give us two lengths. Dividing the sum of two lengths by 2 gives us the length of the rectangle. On the other hand, if we are required to find the length of a square with its perimeter given, dividing the perimeter by 4 gives the length since all 4 sides of a square are of equal length.

Activities

Bring in ropes to the classroom and cut them according to the measurements given in 'Let's Learn' and 'Practice' (Textbook 4 P219 – 221), to form the squares and rectangles. Have pupils carry out hands-on activities to help them understand the concepts and formulae of the perimeter of squares and rectangles.

Resources

- rectangles (Activity Handbook 4 P50)
- rope, wire and/or yarn

Mathematical Communication Support

Emphasise the key terms of perimeter such as 'dimensions', 'length' and 'breadth'. Discuss the properties of rectangles and squares which were taught in Chapter 7. The property of a square – a square has 4 sides of equal length, and the property of a rectangle – a rectangle has 2 pairs of sides of equal length, help pupils understand the formulae of the perimeter of a square and a rectangle.

AREA OF SQUARES AND RECTANGLES

LEARNING OBJECTIVES

1. Find the length of a square given its area.
2. Find one dimension of a rectangle given the other dimension and its area.

AREA OF SQUARES AND RECTANGLES

LESSON
2

IN FOCUS

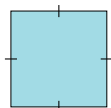

The area of the square is 36 cm^2 .
How can we find the length of the square?

LET'S LEARN

1.

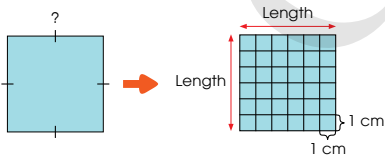

Area of square = Length \times Length

$$36 = 6 \times 6$$

The length of the square is 6 cm.

$1 \times 1, 2 \times 2,$
 $3 \times 3, 4 \times 4, \dots$

Think of a number
that gives 36 when
multiplied by itself.



OXFORD
UNIVERSITY PRESS

AREA AND PERIMETER 222

IN FOCUS

Review the concept of area with pupils. Focus on the relationship between the sides of a square and its area. The common misconception among pupils when finding the side of square is to divide its area by 4. Use the square in the In Focus to correct this misconception.

LET'S LEARN

In Grade Three, pupils learnt the concept of area by counting the number of squares in a figure. Get pupils to count the number of 1-cm squares in the square in Let's Learn 1. Lead pupils to see that the total number of squares can also be obtained by multiplying the two lengths.

Work in pairs.

- 1 Draw a square with an area of 4 cm^2 on  and cut it out.

What you need:



- 2 Record the length of the square.

Example

Area	Length
4 cm^2	

- 3 Repeat **1** and **2** with squares of the given areas.

- | | |
|-----------------------|------------------------|
| (a) 9 cm^2 | (b) 49 cm^2 |
| (c) 16 cm^2 | (d) 64 cm^2 |
| (e) 25 cm^2 | (f) 81 cm^2 |
| (g) 36 cm^2 | (h) 100 cm^2 |

2. A rectangle has an area of 36 cm^2 . The breadth of the rectangle is 3 cm . What is the length of the rectangle?

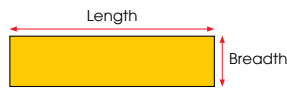

Area of rectangle = Length \times Breadth

$$\text{Length} = 36 \div 3 = 12 \text{ cm}$$

$$12 \times 3 = 36$$



Textbook 4 P223

PRACTICE 

1. Find the length of each square.

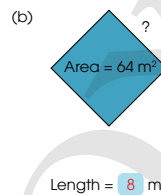
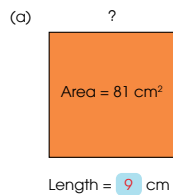

2. Find the length or breadth of each rectangle.

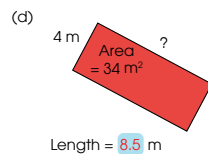
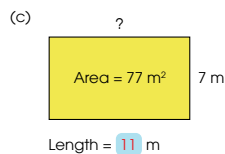
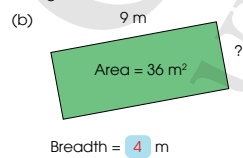
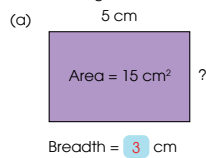

Textbook 4 P224

PRACTICE 

Work on the practice questions with pupils.

For better understanding, select items from **Worksheet 2** and work these out with pupils.

Independent seatwork

Assign pupils to complete Worksheet 2 (Workbook 4B P79 – 82).

1. $5 \times 5 = 25$
The area of the square is 25 cm^2 .
2. $64 = 8 \times 8$
The length of the square is 8 cm.
3. $22 \times 6 = 132$
The area of the rectangle is 132 cm^2 .
4. $63 \div 7 = 9$
The length of the rectangle is 9 cm.
5. $48 \div 4 = 12$
The length of the rectangle is 12 m.
6. (a) $10 \times 10 = 100$
 $10 \times 4 = 40$
Length = 10 cm
Perimeter = 40 cm
(b) $36 \div 9 = 4$
 $9 + 4 + 9 + 4 = 26$
Breadth = 4 m
Perimeter = 26 m
7. (a) $16 \div 4 = 4$
 $4 \times 4 = 16$
Length = 4 cm
Area = 16 cm^2
(b) $38 - 9 - 9 = 20$
 $20 \div 2 = 10$
 $10 \times 9 = 90$
Length = 10 cm
Area = 90 cm^2

OXFORD
UNIVERSITY PRESS

**Specific Learning Focus**

- Find the length of a square given its area.
- Find one dimension of a rectangle given the other dimension and its area.

Suggested Duration

4 periods

Prior Learning

Pupils have learnt multiplication facts using array cards. They have also learnt the concepts of the area of squares and rectangles.

Pre-emptive Pitfalls

Pupils might have the misconception that since a square has 4 sides of equal length, the length of each side can be found by dividing its area by 4. Emphasise that this is incorrect as we are working with area and not perimeter. As square root has not been taught, instead of taking the square root of the area to find the length, recap with pupils the multiplication facts involving the multiplication of two same numbers (e.g. 2×2 , 3×3 , 4×4 , 5×5 , 6×6 , 7×7 , 8×8 , 9×9 , 10×10).

Introduction

Link the concept of array to come up with the formulae of the area of squares and rectangles. In Grade 3, pupils were taught to find the area by counting the squares. Emphasise that an easier way to find the area of a square and a rectangle is by formulae:

- Area of a square = $l \times l$
- Area of a rectangle = $l \times b$

Problem Solving

In 'Practice' (Textbook 4 P224), where the missing dimensions are to be found, since multiplication is used to find the area of a square or a rectangle, its inverse operation, division, is used to find the length or breadth of the square or rectangle.

Activities

Provide pupils with laminated rectangle and square cut-outs. Ask them to carry out the questions in 'Practice' (Textbook 4 P224) on their mini whiteboard. In 'Activity Time' (Textbook 4 P223), encourage pupils to work in pairs. Get them to use ruler, markers, square grid paper and scissors. Have them record their findings in the table.

Resources

- square grid paper (Activity Handbook 4 P24)
- scissors
- ruler
- markers
- mini whiteboard
- squares and rectangles (Activity Handbook 4 P52 – 53)
- table of results (Activity Handbook 4 P51)
- composite figures (Activity Handbook 4 P54)

Mathematical Communication Support

Verbalise the formula of the area of a square in class using the concepts of arrays and multiplication facts of two same numbers. Verbalise the formula of the area of a rectangle in class using the concepts of factors. It should be emphasised that the two units of measure of area covered in this chapter are m^2 and cm^2 .

LESSON

3

AREA AND PERIMETER OF COMPOSITE FIGURES

LEARNING OBJECTIVE

1. Find the area/perimeter of composite figures made up of rectangles and squares.

AREA AND PERIMETER OF COMPOSITE FIGURES

LESSON 3

IN FOCUS

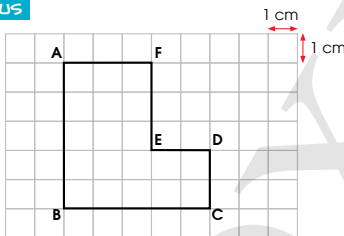

How do we find the perimeter of the figure?

LET'S LEARN

1. We find the perimeter by finding the sum of the lengths of all its sides.

Length of AB = 5 cm
 Length of BC = 5 cm
 Length of CD = 2 cm
 Length of DE = 2 cm
 Length of EF = 3 cm
 Length of FA = 3 cm

$$5 + 5 + 2 + 2 + 3 + 3 = 20$$

The perimeter of the figure is 20 cm.

ABCDEF is a composite figure.
 A composite figure is made up of more than one shape.



IN FOCUS

Discuss with pupils how the perimeter of the figure can be found. Get pupils to explain their answers.

LET'S LEARN

Recap with pupils the properties of squares and rectangles.

Introduce the figure in Let's Learn 1 as a **composite figure**. Get pupils to identify the shapes that form the composite figure and lead pupils to list all the sides and their length. Then work through the example with the pupils.

2. Find the area of the figure.

Method 1

The figure can be separated into a 3 cm by 3 cm square and a 5 cm by 2 cm rectangle.

We **add** the areas of the shapes to find the area of the figure.

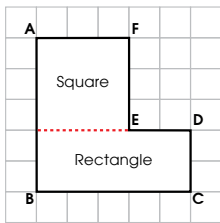

$$\begin{aligned} \text{Area of square} &= 3 \times 3 \\ &= 9 \text{ cm}^2 \end{aligned}$$

$$\begin{aligned} \text{Area of rectangle} &= 2 \times 5 \\ &= 10 \text{ cm}^2 \end{aligned}$$

$$\begin{aligned} \text{Area of the figure} &= 9 + 10 \\ &= 19 \text{ cm}^2 \end{aligned}$$

What other ways can the figure be separated? Which way is better?



It can also be separated into a 3 cm by 5 cm rectangle and a 2 cm by 2 cm square.

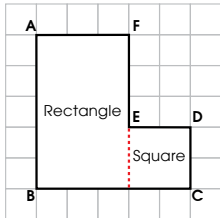

$$\begin{aligned} \text{Area of rectangle} &= 5 \times 3 \\ &= 15 \text{ cm}^2 \end{aligned}$$

$$\begin{aligned} \text{Area of square} &= 2 \times 2 \\ &= 4 \text{ cm}^2 \end{aligned}$$

$$\begin{aligned} \text{Area of the figure} &= 15 + 4 \\ &= 19 \text{ cm}^2 \end{aligned}$$

Textbook 4 P226

In Let's Learn 2, guide pupils to see that the area of a composite figure is the sum of all the shapes that made up the figure.

Method 1

Using the formulae learnt in Lesson 2, guide pupils to find the area of the square and rectangle and finally the area of the figure.

Method 2

We can also find the area of the figure by **taking away** the area of a smaller shape from the area of a bigger shape.

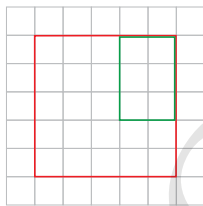

$$5 \times 5 = 25$$

The area of the big red square is 25 cm².

$$2 \times 3 = 6$$

The area of the small green rectangle is 6 cm².

$$25 - 6 = 19$$

The area of the figure is 19 cm².

Can you think of other ways to find the area of the figure?



Method 2

Guide pupils to see that the same composite figure can be formed by removing the green rectangle from the red square. Hence the area of the composite figure can be found by subtracting the area of the green rectangle from the area of the red square.

For class discussion, ask pupils to think of other ways to find the area of the figure.

Textbook 4 P227

3. The figure is made up of rectangles. Find the perimeter of the figure.

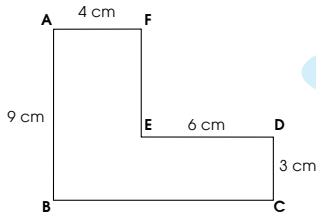

How do we find the lengths of BC and FE?



BC is a horizontal line.

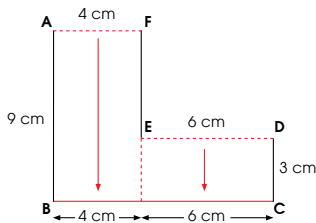

When we slide AF and ED down as shown above, we find that the sum of the lengths of AF and ED is the same as the length of BC.

$$BC = 4 + 6 = 10 \text{ cm}$$

OXFORD UNIVERSITY PRESS

AREA AND PERIMETER 228

Textbook 4 P228

FE is a vertical line.

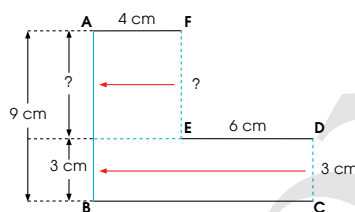

When we slide DC and FE to the left as shown above, we find that the sum of the lengths of FE and DC is the same as the length of AB.

$$FE = 9 - 3 = 6 \text{ cm}$$

$$9 + 10 + 3 + 6 + 6 + 4 = 38$$

$$\text{Perimeter of the figure} = 38 \text{ cm}$$

Work in pairs.

- 1 Paste onto to make a composite figure.
- 2 Find the area and perimeter of the figure.
- 3 Get your partner to check your answer.
- 4 Take turns and repeat 1 to 3.

ACTIVITY TIME

What you need:



Make sure the sides of touch one another.



229 CHAPTER 10

OXFORD UNIVERSITY PRESS

Textbook 4 P229

In Let's Learn 3, pupils need to find the length of BC and FE before they can find the perimeter of the figure. Guide pupils to see the relationships between the different sides of the shapes. Teacher may use magnetic strips to shift the related sides to help pupils visualise.

Work through the example with the class. For class discussion, ask pupils if they can think of other ways to find the perimeter of the figure.

ACTIVITY TIME

Teacher to prepare cutout of squares (example: 4 cm × 4 cm, 5 cm × 5 cm) and rectangles (example: 3 cm × 7 cm, 4 cm × 8 cm) for pupils. The objective of the activity is to help pupils visualise how composite figures can be partitioned into basic shapes.



The lines in each figure meet at right angles.
Find the perimeter and area of each figure.

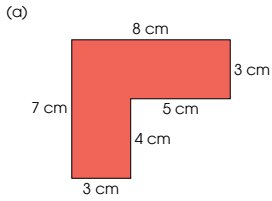

Perimeter = 30 cm

Area = 36 cm²

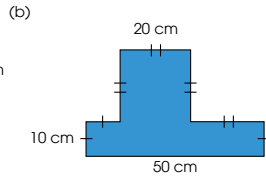

Perimeter = 160 cm

Area = 900 cm²

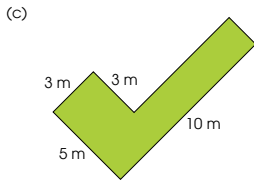

Perimeter = 30 m

Area = 29 m²

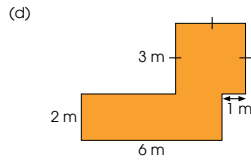

Perimeter = 24 m

Area = 21 m²

Complete Workbook 4B, Worksheet 3 • Pages 83 – 90

Textbook 4 P230



Work on the practice questions with pupils.

For better understanding, select items from Worksheet 3 and work these out with pupils.

Independent seatwork

Assign pupils to complete Worksheet 3 (Workbook 4B P83 – 90).

Answers Worksheet 3 (Workbook 4B P83 – 90)

1. (a) 30
(b) 24
(c) 30
(d) 28

2. (a) 34
(b) 54
(c) 32
*(d) 62

3. Area of Figure A = 28 cm²
Area of Figure B = 33 cm²

4. Area of Figure C = 22 m²
Area of Figure D = 42 m²

5. (a) Perimeter = 62 cm
Area = 148 cm²
(b) Perimeter = 54 m
Area = 72 m²
(c) Perimeter = 48 cm
Area = 140 cm²
*(d) Perimeter = 42 m
Area = 75 m²

MORE ON AREA AND PERIMETER

LEARNING OBJECTIVE

1. Solve problems related to finding the area and perimeter of a rectangle or square.

MORE ON AREA AND PERIMETER

LESSON 4

IN FOCUS

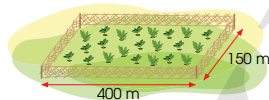

A farmer wants to build a fence around his rectangular vegetable plot. The plot measures 400 m by 150 m. What is the total length of fence he needs?

LET'S LEARN

1.
$$(400 + 150) \times 2 = 550 \times 2 = 1100 \text{ m}$$

He needs 1100 m of fence.

The fence is built around the vegetable plot, so we need to find the perimeter.



2. Meiling made a rectangle using 6 identical squares. The area of the rectangle is 384 cm². What is the length of each square?

$$384 \div 6 = 64$$

The area of each square is 64 cm².

$$64 = 8 \times 8$$

The length of each square is 8 cm.

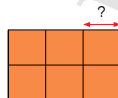

IN FOCUS

Discuss with pupils how the problem can be solved. Get pupils to explain their answers.

LET'S LEARN

Recap with pupils the formula for perimeter of rectangle before getting pupils to attempt Let's Learn 1. Ensure that pupils are not confused by the terms area and perimeter. If necessary, use magnetic strips to illustrate the fence of the vegetable plot.

For Let's Learn 2, allow pupils to work in groups. Distribute six coloured square tiles to each group and get pupils to form the figure in the example. Guide pupils through the solution with the aid of the square tiles.

3. A square photograph is pasted onto a square vanguard sheet. What is the area of vanguard sheet that is not covered by the photograph?

Area of vanguard sheet
 $= 20 \times 20$
 $= 400 \text{ cm}^2$

Area of photograph
 $= 15 \times 15$
 $= 225 \text{ cm}^2$

Area of vanguard sheet not covered
 $= 400 - 225$
 $= 175 \text{ cm}^2$

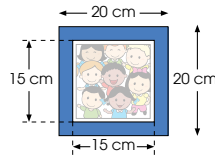

PRACTICE



Solve.

1. A big square is made up of 4 identical small squares. The area of each small square is 25 cm^2 .
 (a) Find the length of each side of the big square.
 (b) What is the perimeter of the big square?



2. A rectangular swimming pool measures 15 m by 8 m. It is surrounded by a path that is 2 m wide. What is the area of the path?

1 a) $5 \text{ cm} \times 5 \text{ cm} = 25 \text{ cm}^2$
 $5 \text{ cm} + 5 \text{ cm} = 10 \text{ cm}$

b) $10 \text{ cm} \times 4 = 40 \text{ cm}$

2) $15 \text{ m} + 4 \text{ m} = 19 \text{ m}$
 $8 \text{ m} + 4 \text{ m} = 12 \text{ m}$
 $19 \text{ m} \times 12 \text{ m} = 228 \text{ m}^2$
 $15 \text{ m} \times 8 \text{ m} = 120 \text{ m}^2$
 $228 \text{ m}^2 - 120 \text{ m}^2 = 108 \text{ m}^2$

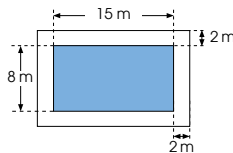

Complete Workbook 4B Worksheet 4 • Pages 91 – 95

OXFORD
UNIVERSITY PRESS

AREA AND PERIMETER

232

Textbook 4 P232

To help pupils visualise, teacher may facilitate by showing two square cutouts ($20 \text{ cm} \times 20 \text{ cm}$ and $15 \text{ cm} \times 15 \text{ cm}$). Illustrate the pasting of the small square onto the big square and shade the part that is not covered by the small square. Lead pupils to see that to find the area of the shaded part, they need to subtract the area of the photograph (small square) from the area of the vanguard sheet (big square).

PRACTICE



Work on the practice questions with pupils.

For better understanding, select items from **Worksheet 4** and work these out with pupils.

Independent seatwork

Assign pupils to complete Worksheet 4 (Workbook 4B P91 – 95).

Answers Worksheet 4 (Workbook 4B P91 – 95)

- $3 \text{ m} \times 4 = 12 \text{ m}$
She must buy 12 m of skirting.
- $70 \text{ m} + 40 \text{ m} + 70 \text{ m} + 40 \text{ m} = 220 \text{ m}$
The total length of fence is 220 m.
- (a) $50 \text{ m} - 3 \text{ m} - 3 \text{ m} = 44 \text{ m}$
 $23 \text{ m} - 3 \text{ m} - 3 \text{ m} = 17 \text{ m}$
 $44 \text{ m} \times 17 \text{ m} = 748 \text{ m}^2$
The area covered by the pool is 748 m^2 .
 (b) $50 \text{ m} \times 23 \text{ m} = 1150 \text{ m}^2$
 $1150 \text{ m}^2 - 748 \text{ m}^2 = 402 \text{ m}^2$
The area of land that is not covered by the pool is 402 m^2 .
- (a) $18 \text{ cm} - 4 \text{ cm} = 14 \text{ cm}$
 $14 \text{ cm} - 4 \text{ cm} = 10 \text{ cm}$
 $14 \text{ cm} \times 10 \text{ cm} = 140 \text{ cm}^2$
The area of the piece of coloured paper is 140 cm^2 .
 (b) $18 \text{ cm} \times 14 \text{ cm} = 252 \text{ cm}^2$
 $252 \text{ cm}^2 - 140 \text{ cm}^2 = 112 \text{ cm}^2$
The area of the card that was not covered by the coloured paper is 112 cm^2 .

- $5 \text{ cm} \times 4 = 20 \text{ cm}$
 $20 \text{ cm} - 2 \text{ cm} - 2 \text{ cm} = 16 \text{ cm}$
 $16 \text{ cm} \div 2 = 8 \text{ cm}$
The length of the rectangle formed is 8 cm.
- Area $\rightarrow 3 \text{ cm} \times 3 \text{ cm} = 9 \text{ cm}^2$
 $9 \text{ cm}^2 \times 7 = 63 \text{ cm}^2$
Perimeter $\rightarrow 3 \text{ cm} \times 14 = 42 \text{ cm}$
The area is 63 cm^2 and the perimeter is 42 cm.
- Area $\rightarrow 2 \text{ cm} + 4 \text{ cm} = 6 \text{ cm}$
 $6 \text{ cm} \times 4 \text{ cm} = 24 \text{ cm}^2$
Perimeter $\rightarrow 2 \text{ cm} + 4 \text{ cm} + 2 \text{ cm} + 4 \text{ cm} + 4 \text{ cm} + 2 \text{ cm} + 2 \text{ cm} = 20 \text{ cm}$
The area is 24 cm^2 and the perimeter is 20 cm.
- Perimeter $\rightarrow 29 \text{ cm} + 21 \text{ cm} + 29 \text{ cm} + 21 \text{ cm} = 100 \text{ cm}$
Area $\rightarrow 29 \text{ cm} \times 21 \text{ cm} = 609 \text{ cm}^2$
The perimeter is 100 cm and the area is 609 cm^2 .

**Specific Learning Focus**

- Find the area/perimeter of composite figures made up of rectangles and squares.
- Solve problems related to finding the area and perimeter of a rectangle or square.

Suggested Duration

4 periods

Prior Learning

Composite figures have been informally introduced in earlier grades, where two-dimensional shapes were used to form pictures and figures.

Pre-emptive Pitfalls

Partitioning the composite figures into rectangles and squares, and finding the correct dimensions to use in the formulae of area and perimeter, might be challenging for some pupils. Hands-on experiences such as the use of rectangle and square cut-outs will help them overcome the challenges they may face.

Introduction

In Lesson 4, get pupils to relate area and perimeter to real-life experiences. For example, in order to know how long the fence of a garden should be, we need to know the perimeter of the garden. Also, finding the amount of surface covered by the garden is equivalent to finding the area of the garden. Point out that perimeter is additive and area is multiplicative. Composite figures are made up of more than one shape. The partitioning of a composite figure into multiple shapes is the core concept of Lesson 3. Once the partitioning is done and the shapes that the composite figure is made up of are identified, the dimensions can be determined. Get pupils to apply the formulae for perimeter and area to find the total area and perimeter of the composite figure. Guide pupils to understand that an alternative method would be to extend the composite figure into one complete rectangle or square and then subtract the shape that was added to complete the square or rectangle (Textbook 4 P227). In Let's Learn 3 (Textbook 4 P228), to get the dimensions, lead pupils to understand that the total length of AF and ED is equal to the length of BC since AF and ED are parallel to BC.

Problem Solving

In 'Activity Time' (Textbook 4 P229), provide pupils with composite figure cut-outs. Get them to partition the shape using dotted lines. Deduce the dimensions and hence apply the formulae to find the area and perimeter of each shape. In Let's Learn 3 (Textbook 4 P232), the area of vanguard sheet not covered by the photograph is to be determined by finding the area of the vanguard sheet and the photograph respectively and then subtracting them.

Activities

Get pupils to use composite figure cut-outs to find the dimensions, area and perimeter through hands-on experiences.

Resources

- square grid paper (Activity Handbook 4 P24)
- scissors
- glue
- composite figures (Activity Handbook 4 P54)

Mathematical Communication Support

Verbalise the dimensions, area and perimeter of the composite figures, to help them visualise the basic shapes. Using square and rectangle cut-outs, and square grid paper, will facilitate understanding of the dimensions of the basic shapes forming the composite figures. Go through the self-check at the end of the chapter and ask pupils for examples learnt from each objective.

PROBLEM SOLVING, MATHS JOURNAL AND PUPIL REVIEW



Mind Workout

Date: _____

A figure is formed by overlapping three identical squares.
Points A, B and C are the centres of the squares.
The total area of the figure is 90 cm^2 .
What is the perimeter of the figure?

$$90 \text{ cm}^2 \div 10 = 9 \text{ cm}^2$$
$$3 \text{ cm} \times 3 \text{ cm} = 9 \text{ cm}^2$$
$$3 \text{ cm} \times 16 = 48 \text{ cm}$$

The perimeter of the figure is 48 cm.

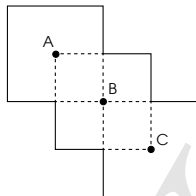

Mind Workout

Guide pupils to understand the requirement of the question. To facilitate, teacher may use magnetic strips to guide pupils.



MIND WORKOUT

The lines in the figure shown meet at right angles. Find its perimeter.

80 cm

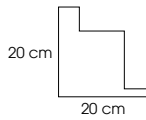

Use sticks to form the figure. You can try shifting the sides.



MATHS JOURNAL

The figure shown is formed with two identical rectangles. Each rectangle measures 30 cm by 10 cm. The shaded part shows where the two rectangles overlap.

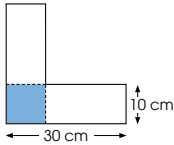

What is the shape of the shaded part of the figure?

How can you use this information to find the area and perimeter of the figure?



Explain how you can find the area and perimeter of the figure.

I know how to...

- find the length of one side of a square.
- find the length or breadth of a rectangle.
- find the area and perimeter of figures made of squares and rectangles.

SELF-CHECK



MIND WORKOUT

Pupils may give fictitious numbers to the unknown sides that add up to 20 cm. Hence, facilitate by explaining to pupils that it is not possible to know the actual measurements of each of these unknown sides but we can find their total.

MATHS JOURNAL

This is a challenging activity which requires pupils to see that the shaded part is a square and its sides are the breadths of the rectangles.

SELF-CHECK



Before the pupils do the self-check, review the important concepts once more by asking for examples learnt for each objective.

This self-check can be done after pupils have completed **Review 10** (Workbook 4B P97 – 100) as consolidation of understanding for the chapter.

1. (a) $72 \text{ cm} \div 4 = 18 \text{ cm}$
 (b) $56 \text{ m} \div 4 = 14 \text{ m}$

2. (a) $54 - 9 - 9 = 36$
 $36 \div 2 = 18$
 Perimeter = 54 cm
 Length = 18 cm

- (b) $36 - 10 - 10 = 16$
 $16 \div 2 = 8$
 Perimeter = 36 cm
 Breadth = 8 cm

3. (a) $4 \times 4 = 16$
 The length is 4 cm.
 (b) $7 \times 7 = 49$
 The length is 7 m.

4. (a) $132 \div 6 = 22$
 Area = 132 cm^2
 Length = 22 cm
 (b) Area = 132 cm^2
 Length = 16.5 cm

5. (a) Perimeter
 $12 \text{ cm} + 10 \text{ cm} + 10 \text{ cm} + 12 \text{ cm} = 44 \text{ cm}$
Area
 $12 \text{ cm} \times 10 \text{ cm} = 120 \text{ cm}^2$
 $12 \text{ cm} - 2 \text{ cm} = 10 \text{ cm}$
 $10 \text{ cm} \times 7 \text{ cm} = 70 \text{ cm}^2$
 $120 \text{ cm}^2 - 70 \text{ cm}^2 = 50 \text{ cm}^2$

- (b) Perimeter
 $32 \text{ cm} + 30 \text{ cm} + 32 \text{ cm} + 30 \text{ cm} = 124 \text{ cm}$
Area
 $32 \text{ cm} \times 30 \text{ cm} = 960 \text{ cm}^2$
 $32 \text{ cm} - 8 \text{ cm} = 24 \text{ cm}$
 $24 \text{ cm} \times 12 \text{ cm} = 288 \text{ cm}^2$
 $960 \text{ cm}^2 - 288 \text{ cm}^2 = 672 \text{ cm}^2$

- (c) Perimeter
 $10 \text{ cm} + 8 \text{ cm} + 10 \text{ cm} + 8 \text{ cm} = 36 \text{ cm}$
Area
 $10 \text{ cm} \times 4 \text{ cm} = 40 \text{ cm}^2$
 $4 \text{ cm} \times 4 \text{ cm} = 16 \text{ cm}^2$
 $40 \text{ cm}^2 + 16 \text{ cm}^2 = 56 \text{ cm}^2$

6. $80 \text{ cm} \div 2 = 40 \text{ cm}$
 $80 \text{ cm} \times 40 \text{ cm} = 3200 \text{ cm}^2$
 The area of the table top is 3200 cm^2 .

7. $9 \text{ m} - 1 \text{ m} - 1 \text{ m} = 7 \text{ m}$
 $7.5 \text{ m} - 1 \text{ m} - 1 \text{ m} = 5.5 \text{ m}$
 $7 \text{ m} \times 5.5 \text{ m} = 38.5 \text{ m}^2$
 The area of the carpet is 38.5 m^2 .

TABLES AND LINE GRAPHS

CHAPTER

11

Tables and Line Graphs

CHAPTER 11

What is another way to record the number of books sold each month?

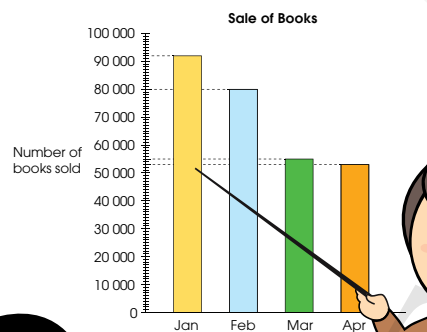

The most number of books was sold in January.



OXFORD
UNIVERSITY PRESS

TABLES AND LINE GRAPHS 234

Textbook 4 P234

Related Resources

NSPM Textbook 4 (P235 – 251)
NSPM Workbook 4B (P101 – 113)

Materials

Newspapers or magazines

Lesson

Lesson 1 Tables
Lesson 2 Line Graphs

Problem Solving, Maths Journal and Pupil Review

INTRODUCTION

Pupils were taught to represent data using both horizontal and vertical bar graphs in Grade Three. The emphasis then was on reading and interpreting the bar graphs to solve problems. In Grade Four, pupils will learn about data presented in a table and in a line graph. Besides reading off the line graph, pupils have to interpret the graphs perceptually. This includes the trend (increasing or decreasing) and the quantity of increase or decrease. Pupils will have hands-on experience using ICT tools to fill up a table to create a bar and line graph in a spreadsheet.

LEARNING OBJECTIVES

1. Complete a table from given data.
2. Read and interpret data from tables.
3. Solve 1-step problems using data from tables.

TABLES

IN FOCUS

Weiming was shown a bar graph that shows the number of books sold each month from January to April. He then recorded the information in a table.

Month	Number of books sold
January	92 000
February	80 000
March	55 000
April	53 000

Do you prefer the bar graph or the table? Why?

LET'S LEARN

1. A **table** allows us to read off the information easily. The table can look like this too.

Month	January	February	March	April
Number of books sold	92 000	80 000	55 000	53 000

Is it easier to compare information using a bar graph or a table?



IN FOCUS

Recap the use of bar graph to represent data. Get pupils to talk about the context of the graph in the Chapter Opener (P234) and discuss with pupils the vertical scale of the bar graph (what each marking represents). Get pupils to read the height of each bar in the bar graph with reference to the vertical scale.

Guide pupils to see how the data from the bar graph can be presented in a table. Help pupils make sense of what the rows and columns represent in the table. Then pose the question from the In Focus to the pupils. Select pupils to share their preference and their reasoning with the class.

LET'S LEARN

Using Let's Learn 1, lead pupils to see that the same data from the table in the In Focus can also be presented in another way. Help pupils make sense of what the rows and columns represent in this table.

2. The cards show the number of bottles and cans picked up by the children.

Ann Bottles ### / Cans ///	Junhao Bottles ### /// Cans //	Weiming Bottles ### Cans ###
Meiling Bottles ### / Cans ///	Ahmad Bottles /// Cans /	Xinyi Bottles ### // Cans ### ###

Show the given information in a table.

Name	Ann	Junhao	Weiming	Meiling	Ahmad	Xinyi
Bottles	6	8	5	6	3	7
Cans	3	2	5	4	1	10

Is there another way to draw the table?

We can use a table to organise information before we draw a graph.



Let's Learn 2 requires pupils to complete the table using data from the tally. Get pupils to talk about the context of the tally. Help pupils make sense of tally and the table. Then lead them to fill in the blanks in the table by getting pupils to count the number of bottles and cans picked by each child.

Explain to pupils how a table can help us organise information before drawing a graph.

Next, allow pupils to work in pairs to find other ways to draw the table. Select pupils to present their tables.

3. The bar graph shows the Mathematics test results of four pupils.

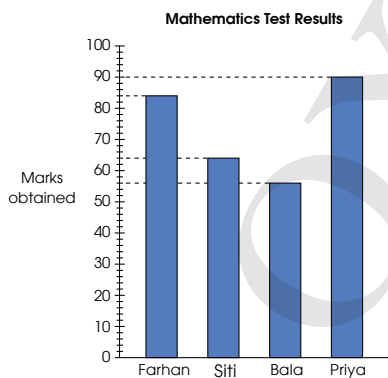

- (a) Complete the table.

Name	Farhan	Siti	Bala	Priya
Marks	84	64	56	90

- (b) Who scored the highest marks? Priya
- (c) Who scored the lowest marks? Bala
- (d) Who scored more marks, Siti or Farhan? Farhan
How many more? 20

Get pupils to talk about the bar graph in Let's Learn 3. To facilitate discussion, ask:

- What is the bar graph about?
- What does each marking on the vertical scale stand for?

Allow pupils to work in pairs to complete the table and answer the 1-step problems before going through the answers.

Work in groups of 4.

ACTIVITY  TIME

- 1 The bar graph below shows the grades scored by pupils from Class 4A in a test. Discuss with your classmates how the data was collected.

What you need:

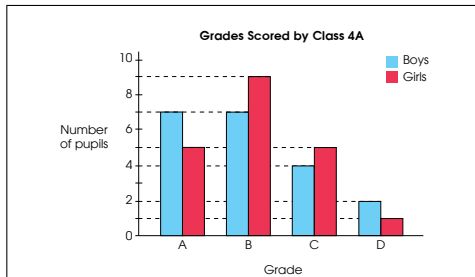

You may use the following questions to help you.

- What information does this bar graph show?
- How many pupils are there in Class 4A?
- How many pupils are girls?
How many pupils are boys?
- What other information has your group found?

- 2 Present your work to the class.

- 3 Can you find similar examples of bar graphs in  ?

Textbook 4 P238

Assign pupils to work in groups of 4. To facilitate the activity, discuss with pupils the context of the graph and help pupils make sense of the bar graph. Select groups to present their answers.

If time permits, get pupils to present the information from the bar graph in a table. Then select groups to present their tables.

PRACTICE 

1. The bar graph shows the colours of the cars in a school carpark.

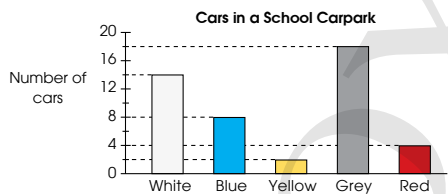

- (a) Complete the table.

Colour	white	blue	yellow	grey	red
Number of cars	14	8	2	18	4

- (b) How many cars were there in the carpark in all? 46

2. The table shows the amount of money four pupils had before a trip and after a trip.

Pupil	Amount of money before the trip	Amount of money spent	Amount of money left after the trip
Tom	\$15	\$11	\$4
Nora	\$11	\$9	\$2
Xinyi	\$20	\$14	\$6
Raju	\$24	?	\$17

- (a) How much money did Raju spend during the trip? \$ 7
- (b) Which pupil spent the most money? Xinyi

 Complete Workbook 4B, Worksheet 1 • Pages 101 – 106

Textbook 4 P239

PRACTICE 

Give pupils sufficient time to work on the questions before going through with the class.

For better understanding, select items from Worksheet 1 and work these out with pupils.

Independent seatwork

Assign pupils to complete Worksheet 1 (Workbook 4B P101 – 106).

1.

Name	Mass (kg)	Height (cm)
Weiming	35	138
Kate	32	130
Farhan	39	142

2.

Class	Boys	Girls	Total number of pupils
4A	18	22	40
4B	10	25	35
4C	23	13	36

3. (a)

Test score	60 and below	61 - 70	71 - 80	81 - 90	more than 90
Number of pupils	Kate	32	130	32	130

(b)

Grade	Number of pupils
A	A
B	B
C	C

4. (a) 37.50
 (b) 58.50
 (c) One large and one medium bag of rice.

5. (a) 11
 (b) 15
 (c) 61
 (d) 35

6. (a) 17
 (b) 48
 (c) Charlie
 (d) Delta
 (e) Bravo

LESSON

2

LINE GRAPHS

LEARNING OBJECTIVES

1. Read and interpret data from line graphs.
2. Solve 1-step problems using data from line graphs.

LINE GRAPHS

IN FOCUS

Month	January	February	March	April
Number of books sold	92 000	80 000	55 000	53 000

We have learnt how to present the information in a bar graph. How can we draw another graph to show the same information?

LET'S LEARN

1. We can also use a **line graph** to show the number of books sold from January to April.

Sale of Books

Each dot on the graph tells you the number of books sold in a particular month.

LESSON

2

IN FOCUS

LET'S LEARN

OXFORD UNIVERSITY PRESS TABLES AND LINE GRAPHS 240

Textbook 4 P240

Recap the bar graph and table from the Chapter Opener, In Focus and Let's Learn 1 of Lesson 1 (P234 – 235). Pose the question from the In Focus to the pupils. Get pupils to talk about other types of graphs they may have seen before.

Line graph is introduced in Let's Learn 1 with the aid of the bar graph from the Chapter Opener (P234).

Lead pupils to see that instead of bars, the dots are used to represent the reading of each month. Then guide pupils to find the number of books sold for each month with reference to the vertical scale.

2. How did the sale of books change from January to April?

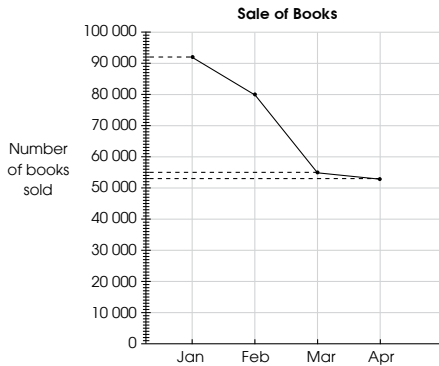

A line graph shows the pattern of information over time.

From the line graph, we can tell that the sale of books decreased from January to April.

We can also say that the number of books sold fell from January to April.



241 CHAPTER 11

OXFORD UNIVERSITY PRESS

Textbook 4 P241

Using Let's Learn 2, ask pupils:

- Do you think the number of books sold are increasing or decreasing from January to April?

Then guide pupils to see that the line graph shows a decreasing pattern.

Next get pupils to read and interpret the graph by asking pupils:

- Which two consecutive months saw the greatest drop in the sale of books?
- Which two consecutive months saw the least drop in the sale of books?

3. The line graph shows the prices of movie tickets in different years.

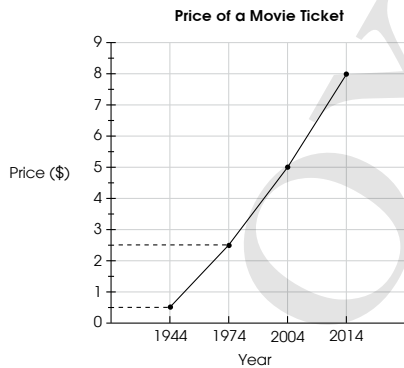

- (a) What was the price of a movie ticket in 1974? **\$2.50**
- (b) In which year was the price of a movie ticket the most expensive? **2014**
- (c) What is the difference between the price of a movie ticket in 1944 and in 2004? **\$4.50**

Did the price of the movie ticket increase or decrease over the years?



OXFORD UNIVERSITY PRESS

TABLES AND LINE GRAPHS 242

Textbook 4 P242

Discuss the context of the line graph in Let's Learn 3 with the pupils. Then work through the questions with the pupils. For class discussion, ask pupils what they think happened to the price of movie tickets from 1944 to 2014.

4. The line graph shows the change in the temperature of a glass of water left in a freezer over a period of time.

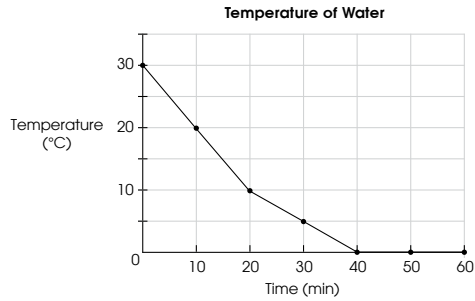

- (a) Complete the table.

Time (min)	0	10	20	30	40	50	60
Temperature (°C)	30	20	10	5	0	0	0

- (b) What was the temperature of the water in the glass at the beginning? **30 °C**
- (c) How much did the temperature drop after the glass was left in the freezer for 20 minutes? **20 °C**
- (d) What do you notice about the temperature of the water after the glass had been left in the freezer for more than 40 minutes?
It remained the same at 0°C.

Did the temperature increase, decrease or remain the same?



5. The line graph shows the amount of rainfall from August to December in 2012.

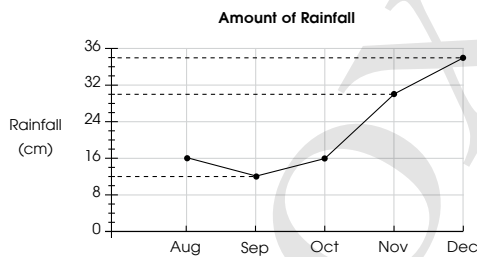

- (a) The greatest amount of rainfall was recorded in **December**.
- (b) The least amount of rainfall was recorded in **September**.
- (c) The amount of rainfall recorded was the same in **August** and **October**.
- (d) There was a decrease in the amount of rainfall from **August** to **September**.
- (e) From September to December, there was (an increase/ a decrease) in the amount of rainfall.

Let's Learn 4 features a constant reading from 40th min to the 60th min. Discuss the context of the line graph with the pupils. Ask pupils what they think will happen to the temperature of water that has been left in a freezer over a period of time.

Next draw pupils' attention to the graph from the 40th min onwards. Lead pupils to see that the reading is constant at zero for the 40th, 50th and the 60th min. Then guide pupils to fill up the table and work through the solutions.

The line graph in Let's Learn 5 shows both increasing and decreasing trend. Discuss the context of the graph with the pupils to help them make sense of the measurement of rainfall. Work through the answers with the pupils.

For class discussion, draw pupils' attention to the downward slope (August to September) and the upward slope (September to December) of the line graph and ask pupils what they have observed.

6. The table shows the number of books sold at the book fair every hour.

Time	Number of Books Sold
2.00 p.m.	30
3.00 p.m.	40
4.00 p.m.	10
5.00 p.m.	20
6.00 p.m.	20

Draw a line graph that represents the data.

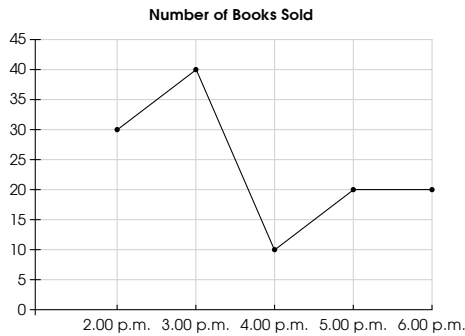

Guide pupils to draw a line graph based on the data shown in the table. Lead pupils to first plot the points on the grid lines and then draw straight lines to join the points to draw the line graph.

Work in groups of 4.

- 1 Study the table given.

Table 1 Height of five 6-year-old boys

Name	Height (cm)
Sam	121
Junhao	100
Ahmad	114
Bala	106
Tom	125

- 2 Go to <http://www.shinglee.com.sg/StudentResources/NSPM4>. Open the spreadsheet 'Tables and Line Graphs'.

- 3 Fill in the information given to create a bar graph and a line graph. Which graph would you use to present the information? Why?

- 4 Repeat 1 to 3, using information in Table 2.

Table 2 Height of Weiming

Age (years)	Height (cm)
2	80
4	94
6	110
8	121
10	140

When should we use line graphs to present the information?



ACTIVITY TIME

Assign pupils to work in groups of 4.

The objective of the activity is for pupils to fill in the table to create a bar and line graph then compare the two types of graph.



1. The line graph shows the monthly rainfall of a town from August to December.

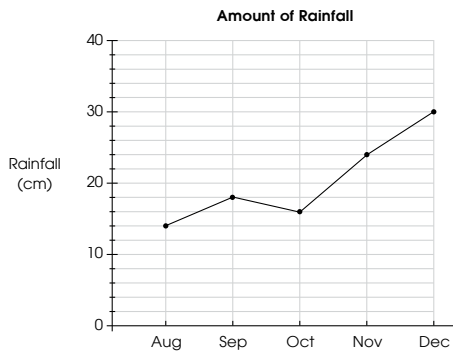

Study the line graph and answer the following questions.

- (a) Which was the wettest month? **December**
- (b) Which was the driest month? **August**
- (c) What was the difference in the amount of rainfall between the wettest month and the driest month? **16 cm**
- (d) How much more rainfall was recorded in November than in October? **8 cm**

Textbook 4 P247

Give pupils sufficient time to work on the practice questions before working through with the class. If necessary, facilitate by helping pupils make sense of the context of each graph and the markings on the vertical scale.

2. A marathon is held once a year. The line graph shows the number of runners in the marathon from 2010 to 2014.

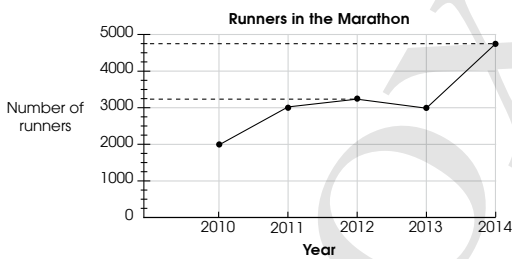

- (a) In which year was the number of runners twice that of the year before? **none**
- (b) The number of runners in **2011** was the same as that in **2013**.
- (c) Between which one-year period was the increase in the number of runners the greatest? **2013** and **2014**
- (d) Describe the change in the number of runners between 2010 and 2012.
It increased.

Which line represents the greatest increase?



If time permits, get pupils to present their answers.

For better understanding, select items from Worksheet 2 and work these out with pupils.

Textbook 4 P248

3. The table shows the temperature in Karachi over a 12-hour period.

Time	Temperature (°C)
9.00 a.m.	20
11.00 a.m.	22
1.00 p.m.	25
3.00 p.m.	24
5.00 p.m.	22
7.00 p.m.	19
9.00 p.m.	18

Draw a line graph that represents the data.

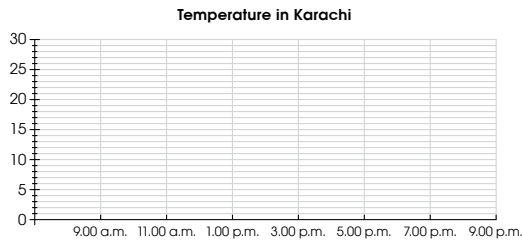

Complete Workbook 4B, Worksheet 2 • Pages 107 – 110

Check if pupils are able to draw the line graph correctly. Remind them to plot the points first, based on the data shown in the table, and use a ruler to draw the line graph.

Independent seatwork

Assign pupils to complete Worksheet 2 (Workbook 4B P107 – 110).

Answers Worksheet 2 (Workbook 4B P107 – 110)

1.

Year	2002	2003	2004	2005	2006
Number of trophies	50	30	40	20	35

2. (a) Sunday
 (b) Thursday
 (c) Monday, Tuesday and Friday
 (d) 100

3. (a)

From 2010 to 2011	200
From 2011 to 2012	100
From 2012 to 2013	300

- (b) 2012 to 2013
 (c) increased

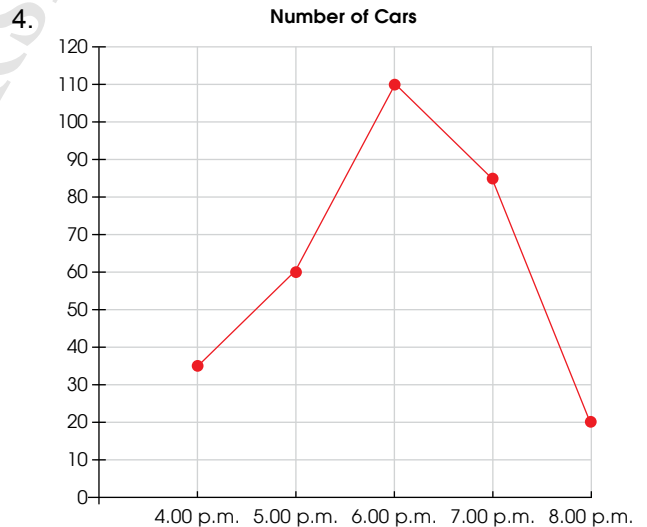

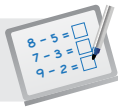
**Specific Learning Focus**

- Complete a table from given data.
- Read and interpret data from tables.
- Solve 1-step problems using data from tables.
- Read and interpret data from line graphs.
- Solve 1-step problems using data from line graphs.

Suggested Duration

Lesson 1: 4 periods
Lesson 2: 6 periods

Prior Learning

Pupils should be well-versed with tally charts and representing data presented in tables by drawing horizontal and vertical bar graphs. Pupils have learnt to interpret picture graphs and bar graphs, deduce information from the graphs, and answer questions related to the data trend (e.g. most or least popular item).

Pre-emptive Pitfalls

This chapter should be a relatively easy chapter. Relating tables and data to real-life situations will enhance pupils' interest in the topic and hence help them to understand the statistical strand of Mathematics.

Introduction

In Lesson 2, pupils are introduced to line graphs. Pupils are required to interpret data in a table and tell the trend of the data. For example, if the data is about the favourite food among a group of people, they should be able to tell the least and most popular food, and hence relate the least popular food to the least quantity, and the most popular food to the greatest quantity. Revisit bar graphs, and guide pupils to draw a bar graph based on the information given in the table in 'In Focus' (Textbook 4 P235). Emphasise the horizontal and vertical scale of a bar graph, and the markings of values on the axes, upon deciding on the intervals between values. Guide pupils to relate the information in the table to the bar graph. Ask pupils if they prefer the bar graph or the table, giving mathematical reasoning to support their answer. Revisit the concept of tally marks, where tally marks are grouped in fives, with the fifth tally mark in each group as a slash across four vertical tally marks. In Let's Learn 3 (Textbook 4 P237), put the results shown in the second row of the table on the vertical axis of the bar graph. The subject of the data, which in this case is the name of pupils (shown in the first row of the table), is represented on the horizontal axis. Emphasise that the bars in a bar graph are drawn with gaps between them. In Lesson 2, line graphs are introduced as the systematic plotting of points that relate to the horizontal and vertical scale, and are then joined by straight lines.

Problem Solving

Both bar and line graphs, just like pictograms, represent information. Interpretation of the data, analysing the data trend (increase or decrease) and drawing inferences from the data form the critical thinking and application of Data Analysis and Statistics. Emphasise the significance of upward and downward slope in a line graph.

Activities

'Activity Time' (Textbook 4 P238, 246) encourage pupils to explore statistic data provided in other sources (newspapers/online resources) and then create their own market survey, where they can collect the results and then represent the data using a bar or line graph, depending on which one they think is better. Encourage verbal discussions for their choice of bar or line graph. Provide pupils with chart paper and markers and ask them to present their data, to be put up on the softboard.

Resources

- newspapers or magazines
- chart paper
- ruler
- computer (ICT)
- markers

Mathematical Communication Support

Drawing inferences from the interpretation of data is the key aspect of statistics. Reading and interpreting bar and line graphs to solve problems can be done by verbalising the questions in the Textbook and Workbook in class. Once the pupils are confident, they can then be assigned independent seatwork. Comparing data and drawing inferences backed by mathematical reasoning (steepness of the line graph, downward or upward slope, height of the bars) need to be analysed when interpreting the graphs and drawing conclusion. Discuss various angular motions in real life, like the gradient of an airplane taking off from the ground or the opening of a window. Two-dimensional figure cut-outs can be distributed to pupils and they can visually predict acute, obtuse and right angles in the shapes (Activity Handbook 3 P40). Explain the concepts of angles as:

- An angle is formed when two lines meet at a point.
- When two perpendicular lines meet at a point, a right angle is formed.
- An angle smaller than a right angle is an acute angle.
- An angle greater than a right angle but smaller than 180° is an obtuse angle.

PROBLEM SOLVING, MATHS JOURNAL AND PUPIL REVIEW



MIND WORKOUT

The table shows the number of visitors at an art exhibition over a period of one week.

Day	Friday	Saturday	Sunday
Number of visitors	1950	2600	2550

Which line graph matches the information given in the table?

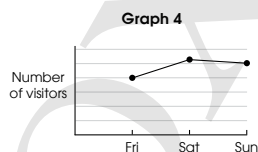
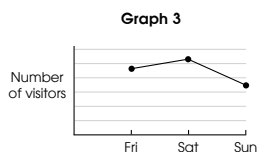
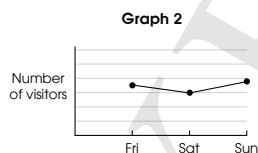
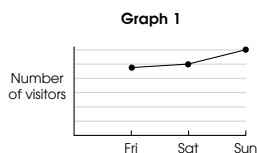

Ans: Graph 4

OXFORD
UNIVERSITY PRESS

TABLES AND LINE GRAPHS 250



MIND WORKOUT

Pupils are to make sense of the numbers in the table and visualise how the curve should look like. Remind pupils not to write values on the vertical scale for this exercise but to estimate instead.

Textbook 4 P250



Mind Workout

Date: _____

The number of pupils in each of the four co-curricular activity (CCA) groups is shown in the table below.

CCA	Tennis	Soccer	Choir	Band
Number of pupils	25	29	27	19

Which bar graph matches the information given in the table? **Graph C**

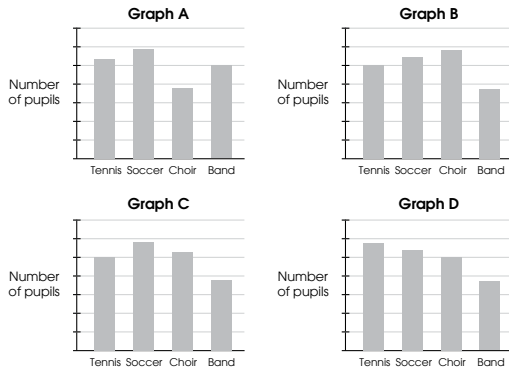

OXFORD
UNIVERSITY PRESS

Tables and Line Graphs 111

Workbook 4B P111



Mind Workout

This Mind Workout is an extension of the Mind Workout in the textbook (P250). If necessary, facilitate by asking pupils:

- Which CCA has the tallest bar?
- Which CCA has the shortest bar?

MATHS JOURNAL

The following line graph shows the amount of money Kate saved.

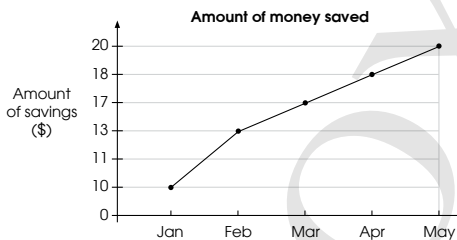

Priya and Tom are talking about the graph.



The increase in savings from February to March and March to April is the same.



The increase in savings from February to March is greater than the increase in savings from March to April.

Who is correct? Explain.

I know how to...

- present information in the form of a table.
- read and interpret tables and line graphs.
- solve problems using information from tables and graphs.

SELF-CHECK



251 CHAPTER 11

OXFORD
UNIVERSITY PRESS

Textbook 4 P251

MATHS JOURNAL

Pupils may be quick to conclude that Priya is right based on the steepness of the slope. Focus their attention on the vertical axis, ask pupils what they think is 'not correct'. Get pupils to present their findings. Then lead them to compare Kate's savings (February to March and March to April) by reading off the data points and comparing the differences.

Before the pupils do the self-check, review the important concepts once more by asking for examples learnt for each objective.

This self-check can be done after pupils have completed **Review 11** (Workbook 4B P112 – 113).

SELF-CHECK



1. (a) 50
(b) 40
(c) 35
(d) 20

2. (a) 800
(b) 100
(c) 2011, 2012
(d) It increases.

OXFORD
UNIVERSITY PRESS

Time

CHAPTER 12

Nora and her family are taking AX123 to return to Islamabad. What time is their flight in the 12-hour clock?

Time	Flight	Destination	Gate	Status
12:00	VQ2382	BRUNEI	A4	DEPARTED
12:15	PT301	BANGKOK	C4	DEPARTED
12:30	LR468	HONG KONG	B13	GATE CLOSING
12:35	WR980	JAKARTA	G3	BOARDING
13:00	AX123	ISLAMABAD	A21	GATE OPEN
13:25	ES218	LONDON	D1	GATE OPEN
14:35	RC2189	BRISBANE	F12	
15:00	TAT497	TAIPEI	B2	



24-HOUR CLOCK

IN
FOCUS

Nora and her family flew back from Singapore to Islamabad.

Time	To	Flight	Status
13 00	Islamabad	AX123	Departed

Their flight departed from Singapore at 13 00.
What is the departure time in the 12-hour clock?

OXFORD UNIVERSITY PRESS
LESSON
1
TIME 252

Textbook 4 P252

Related Resources

NSPM Textbook 4 (P252 – 265)
NSPM Workbook 4B (P114 – 127)

Materials

Stopwatch, geared clock, drawing block, markers

Lesson

Lesson 1 24-Hour Clock
Lesson 2 Duration of Time
Lesson 3 Solving Word Problems

Problem Solving, Maths Journal and Pupil Review

INTRODUCTION

In Grade Three, pupils learnt to tell time and duration of time using the 12-hour clock. In Grade Four, they will now learn to tell time using the 24-hour clock. They will solve problems involving start time, finishing time and duration using both the 12 and 24-hour clock. The learning experiences will help pupils develop a sense of 10 seconds by finding out how many numbers they can count in that duration. Pupils will also work in groups to create word problems involving 24-hour clock for other groups to solve.

LESSON

1

24-HOUR CLOCK

LEARNING OBJECTIVE

1. Tell time in 24-hour clock.

Time
CHAPTER 12

Nora and her family are taking AX123 to return to Islamabad. What time is their flight in the 12-hour clock?

Time	Flight	Destination	Gate	Status
12:00	VQ202	SHANGHAI	A5	DEPARTED
12:15	PK301	BANGKOK	C4	DEPARTED
12:30	LR661	HONG KONG	B13	GATE CLOSING
12:35	WY901	JAKARTA	G3	BOARDING
13:00	AX123	ISLAMABAD	A11	GATE OPEN
13:30	ES210	LONDON	B1	GATE OPEN
14:00	SC210P	HONGKONG	F12	
15:00	TA907	WUHAN	B2	

24-HOUR CLOCK

IN **FOCUS**

Nora and her family flew back from Singapore to Islamabad.

Time	To	Flight	Status
13 00	Islamabad	AX123	Departed

Their flight departed from Singapore at 13 00.
What is the departure time in the 12-hour clock?

LESSON

1

OXFORD UNIVERSITY PRESS
TIME 252

IN FOCUS

Focus pupils' attention on the column 'Time' in the Chapter Opener. Ask pupils what they think is the departure time of the flight AX123 departing from Penang for Singapore.

Textbook 4 P252

LET'S LEARN

1. There are 24 hours in a day.

1 o'clock in the morning or **1.00 a.m.** is **01 00**.

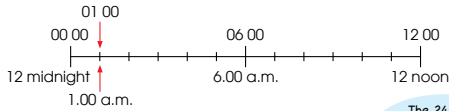

We read 01 00 as **zero one hundred hours**.
How do you read 13 00?



1 o'clock in the afternoon or **1.00 p.m.** is **13 00**.

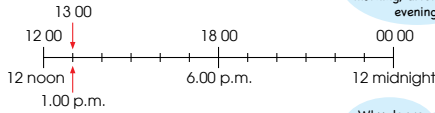

The 24-hour clock allows us to tell if the time refers to morning, afternoon or evening.



The plane departed from Singapore at 1.00 p.m.

Why do we write 1.00 p.m. as 13 00?

2. What is 1 minute after 11.59 p.m.?



1 minute after 11.59 p.m. is 12 midnight.
11.59 p.m. is 23 59.
12 midnight is 00 00.

253 CHAPTER 12

OXFORD UNIVERSITY PRESS

Textbook 4 P253

LET'S LEARN

Using Let's Learn 1, make connections between the 12-hour and 24-hour clock. Draw a time line on the board starting with 12 midnight (00 00) and ending with 12 noon (12 00) with 11 markings in between. Lead the class to fill in the time line with both 12 and 24-hour time; 1.00 a.m. is **zero one hundred hours** (01 00), 2.00 a.m. is **zero two hundred hours** (02 00), ...

Draw another time line, starting with 12 noon (12 00) and ending with 12 midnight (00 00) with 11 markings in between. Repeat the same process.

For class discussion, ask pupils why the 24-hour clock is used in flight and train schedules.

Using Let's Learn 2, explain to pupils that 11.59 p.m. or 23 59 is the last minute of the day. 12 midnight or 00 00 is the end of a day and the start of another day.

3. (a)



A train left the station at **10.15** p.m.
The time in the 24-hour clock is **22 15**.

(b)



An examination started at 11 34.
The time in the 12-hour clock is **11.34 a.m.**

PRACTICE



- Write the time using the 24-hour clock.

(a) 8.30 a.m. 08 30	(b) 12 noon 12 00
(c) 4.55 p.m. 16 55	(d) 12.05 a.m. 00 05
- Write the time using the 12-hour clock.

(a) 07 15 7.15 a.m.	(b) 12 45 12.45 p.m.
(c) 15 35 3.35 p.m.	(d) 23 10 11.10 p.m.

OXFORD UNIVERSITY PRESS

TIME 254

Textbook 4 P254

PRACTICE



Work with pupils on the practice questions.

For better understanding, select items from **Worksheet 1** and work these out with the pupils.

Independent seatwork

Assign pupils to complete Worksheet 1 (Workbook 4B P114 – 115).

3. The table shows the ferry schedule from a cruise centre to a neighbouring island.

Departure time	Cruise Operator	Status
7.10 a.m.	Star Ferry	Departed
7.40 a.m.	Fast Ferry	Departed
8.10 a.m.	Fast Ferry	Confirmed
2.00 p.m.	Happy Cruise	-
3.10 p.m.	Star Ferry	-
5.30 p.m.	Star Ferry	-

- (a) Two ferries from Fast Ferry are departing for the island. What are their departure times in the 24-hour clock?
07 40 and 08 10
- (b) What is the departure time of the last ferry from Star Ferry in the 24-hour clock?
17 30
- (c) Happy Cruise has only one ferry departing for the island. What is the departure time in the 24-hour clock?
14 00
- (d) Meiling was on board a ferry which departed at 15 10. Write the name of the cruise operator.
Star Ferry

Complete Worksheet 1 • Pages 114 – 115

Textbook 4 P255

Answers Worksheet 1 (Workbook 4B P114 – 115)

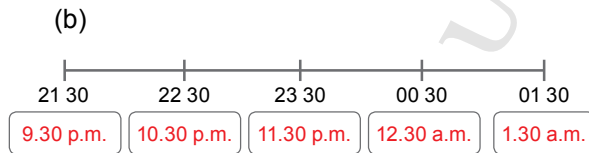
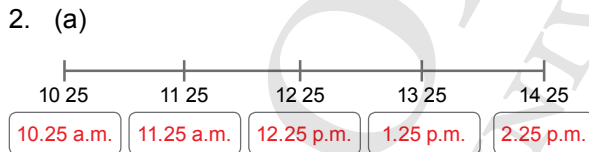
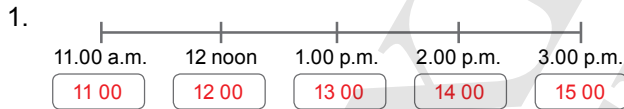

4.

24-hour clock	12-hour clock
04 40	4.40 a.m.
08 50	8.50 a.m.
12 31	12.31 p.m.
15 22	3.22 p.m.
20 40	8.40 p.m.
00 35	12.35 a.m.

3.

12-hour clock	24-hour clock
6.00 a.m.	06 00
9.10 a.m.	09 10
12.45 p.m.	12 45
2.40 p.m.	14 40
8.04 p.m.	20 04
12.15 a.m.	00 15

**Specific Learning Focus**

- Tell time in 24-hour clock.

Suggested Duration

2 periods

Prior Learning

Pupils have learnt to tell time in 12-hour clock. They should be able to calculate the duration of time and find the ending time. They should understand the notations 'a.m.' and 'p.m.' and that 12 noon is the start of the p.m. times and 12 midnight is the start of the a.m. times. Lead pupils to relate the sequence of events to time.

Pre-emptive Pitfalls

Associating and expressing time in the 24-hour clock notation might be a bit confusing for some pupils as they are probably used to the 12-hour clock.

Introduction

Introduce to pupils that the 24-hour clock easily tells us if the time is in the morning, afternoon or evening. Guide pupils to make connections between the 12-hour clock and 24-hour clock. Explain to pupils that the time 00 00 in 24-hour clock is 12.00 a.m. in 12-hour clock. Point out that 00 00 is the end of a day and the start of another day. After 00 00, for each hour that passes, the hour increases by 1. Using Let's Learn 2 (Textbook 4 P253), explain the correlation that 11.59 p.m. or 23 59 is one minute before 12 midnight or 12.00 a.m. or 00 00.

Problem Solving

Get pupils to relate the same time in 12-hour clock and 24-hour clock. For example, explain to pupils that 11 00 or 11.00 a.m. refer to the same time, just in different clock notations (12-hour and 24-hour clock notations).

Activities

Question 3 in 'Practice' (Textbook 4 P255) can be done as an activity in class, with the ferry, local train or airport timetable put up in class and questions asked. Pupils can be divided into groups and get them to present their answers to the class.

Resources

- stopwatch
- geared clock
- ferry, local train or airport schedule
- chart paper
- markers

Mathematical Communication Support

Encourage pupils to work in groups and create word problems involving 24-hour clock for other groups to solve. Articulate the times in different forms (e.g. fourteen hundred hours in 24-hour clock is 2.00 p.m. in 12-hour clock). Encourage individual responses when asking for the time in 12-hour or 24-hour clock.

LEARNING OBJECTIVE

1. Measure time in seconds.

DURATION OF TIME

LESSON
2

IN
FOCUS

What is Raju's timing?

We can use a stopwatch to measure seconds.

LET'S LEARN

Measuring Time in Seconds

1.

→

We write 's' for seconds.

The stopwatch shows that 16 **seconds** has passed. Raju ran 100 m in 16 s.
2.

Priya ran a 400-m race. Her finishing time is shown on the stopwatch.

She ran 400 m in 1 min 15 s.

OXFORD UNIVERSITY PRESS
TIME 256

Textbook 4 P256

IN FOCUS

Recap measuring time in minutes which they learnt in Grade Three. Elicit the answer from pupils on the time shown in the In Focus.

LET'S LEARN

Using Let's Learn 1, explain that the stopwatch measures in minutes and seconds. Hence, the time shown on the stopwatch is 16 seconds. Tell pupils that there are 60 seconds in a minute.

Next, allow pupils to experience a 16 seconds time frame using a stopwatch.

For Let's Learn 2, guide pupils to read the timing on the stopwatch as 1 min 15 s.

3.

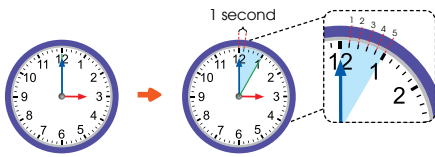

Each small marking on the clock face stands for 1 second. The second hand shows 5 s, so 5 s have passed.

4.

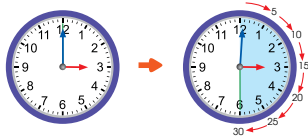

After 30 seconds, the second hand moves from 12 to 6.

5. How many seconds have passed?

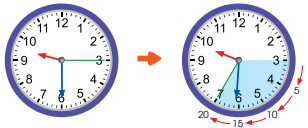

The second hand moved from 3 to 7. 20 s have passed.

257

CHAPTER 12

OXFORD UNIVERSITY PRESS

Textbook 4 P257

Using Let's Learn 3, explain that each small marking on the clock face is 1 second. When the second hand (green) moves from a number to the next, 5 s have passed.

For Let's Learn 4, lead the pupils to count (in 5s) the number of seconds passed when the second hand moves from 12 to 6. Then conclude that when the second hand turns through half the clock face, 30 s have passed.

Repeat the same process for Let's Learn 5. Lead the pupils to count (in 5s) the number of seconds passed when the second hand turns from 3 to 7 (20 s).

6.

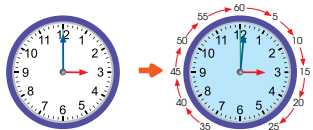

The second hand makes a complete round in 60 s. The minute hand moves by one small marking. 1 minute after 3.00 p.m. is 3.01 p.m.

1 min = 60 s



ACTIVITY TIME

Work in pairs.

- 1 Guess how many numbers you can count in 10 s. What you need:
- 2 Ask your partner to time 10 s on the and count starting from 1. Which number did you stop at?
- 3 Take turns and repeat 1 to 2.
- 4 Try doing other activities in 1 min.

IN

FOCUS



Kate reached the shopping centre at 11 35. She spent 1 hr 10 min shopping before going home. At what time did she leave the shopping centre?

OXFORD UNIVERSITY PRESS

TIME 258

Textbook 4 P258

ACTIVITY TIME

For Let's Learn 6, lead the pupils to count (in 5s) the number of seconds passed when the second hand turns one complete round. Then conclude that the second hand turns one complete round in 60 s and when the second hand turns one complete round, the minute hand moves by one small marking. Hence, 1 min is equal to 60 s.

The activity allows pupils to develop a sense of a 10 seconds time frame. Other suggested activities:

- How many words can you write in 10 seconds?
- How many circles can you draw in 10 seconds?
- How many multiples of 4 can you list in 10 seconds?

IN



FOCUS

Discuss with pupils how the problem can be solved. Get pupils to explain their answers.

LET'S LEARN

Duration in 24-hour clock

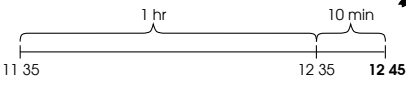

We can use a timeline to show the time taken.

1.  
 She left the shopping centre at 12 45.

2. Meiling and her family took a flight from Penang to Hong Kong.

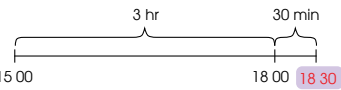

The flight was 3 hr 30 min long.
 At what time did they reach Hong Kong?

 Meiling and her family reached Hong Kong at 18 30. 

Can you draw the timeline using the 12-hour clock?

3. Tom left his house at 09 55.
 He returned home at 12 25.
 How long was he away from home?

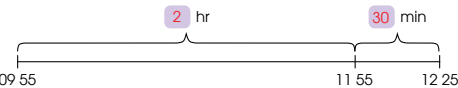
 He was away from home for 2 hr 30 min.

Textbook 4 P259



LET'S LEARN

Use a timeline to show how the problem can be solved. Remind pupils to leave their answers in 24-hour clock.

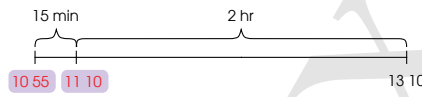

Use the timeline to find the arrival time in Let's Learn 2. Explain to pupils that it is easier to add the hours first, followed by the minutes. If time permits, get pupils to draw the timeline using the 12-hour clock.

Continue to show pupils how the timeline is used to solve problems involving the duration of time. Remind pupils not to repeat the common mistake of subtracting 11 55 from 12 25 to find the duration. For class discussion, get pupils to suggest other ways of segmenting the timeline.

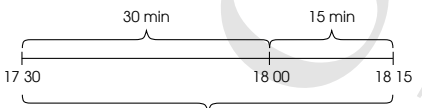

4. Weiming spent 2 hr 15 min at a carnival.
 He left the carnival at 13 10.
 What time did he arrive at the carnival?

 He arrived at the carnival at 10 55. 
 15 min = 5 min + 10 min

5. A flight from Perth to Singapore was supposed to arrive at 17 30.
 There was a delay and it landed at 18 15 instead.
 How long was the flight delayed for?

 The flight was delayed for 45 min. 
 Is there another way to find the duration of the delay?

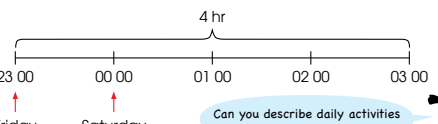
6. A flight from Singapore to Hong Kong is scheduled at 23 00 on Friday.
 The flight is 4 hours long.
 When will the plane reach Hong Kong?

 The plane will reach Hong Kong at 03 00 on Saturday. 
 Can you describe daily activities using the 24-hour clock?

Textbook 4 P260

Work through Let's Learn 4 with the pupils to find the start time (the time Weiming arrived at the carnival) using the timeline. Explain to pupils that it is easier to subtract the hours first, followed by the minutes.

Allow pupils to work in pairs for Let's Learn 5 before going through. Remind pupils to use a timeline to find the duration of the delay. For class discussion, ask pupils to suggest other ways of finding the duration of the delay.

Let's Learn 6 requires pupils to find the end time that crosses over to the next day. Work through the example with the class using a timeline. Focus pupils' attention on 00 00, which is the beginning of another day (Saturday).



PRACTICE



1. Sam reached the concert hall at 13 35. He waited for 15 minutes before the concert started. The concert lasted for 2 hr 20 min. What time did the concert end?

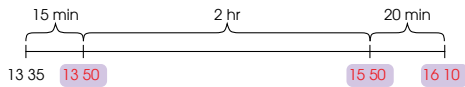

The concert ended at 16 10.

2. Junhao left his house at 17 25 and went for a walk. He returned home at 19 10. How long did he walk?

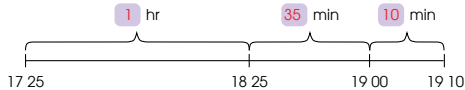

He walked for 1 hr 45 min.

3. Xinyi and her family boarded a flight from Singapore to Taiwan. The duration of the flight was 4 hr 45 min. They reached Taiwan at 22 40. What time did they board the flight?

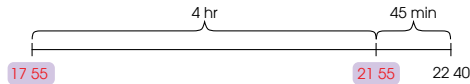

They boarded the flight at 17 55.

Complete Worksheet 2 • Pages 116 – 119

Textbook 4 P261

Work with pupils on the practice questions.

For better understanding, select items from **Worksheet 2** and work these out with the pupils.

Independent seatwork

Assign pupils to complete Worksheet 2 (Workbook 4B P116 – 119).

Answers Worksheet 2 (Workbook 4B P116 – 119)

1. (a) 10 15
(b) 14 05

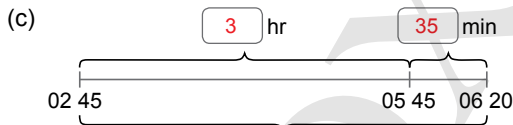

The flight was 3 hr 35 min long.

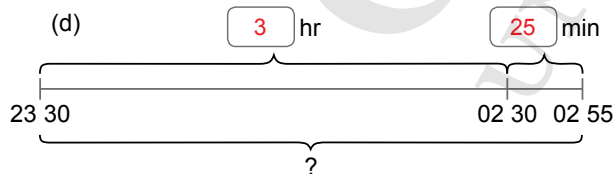

The awards show lasted for 3 hr 35 min.

- (e) 10 20
(f) 22 15

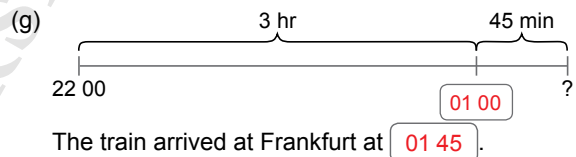

The train arrived at Frankfurt at 01 45.

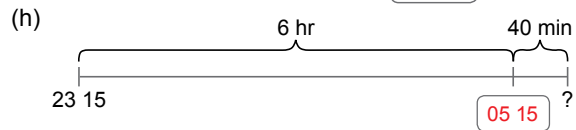

Raju woke up at 05 55.

**Specific Learning Focus**

- Measure time in seconds.

Suggested Duration

2 periods

Prior Learning

This lesson is in continuation from Lesson 1. In Grade 3, pupils learnt to calculate duration of time, starting and ending times in the 12-hour clock notation.

Pre-emptive Pitfalls

In Grade 4, pupils will also learn to calculate duration of time, starting and ending times, but using times in the 24-hour clock notation. Pupils need to be well-versed with the 24-hour clock before the teacher can proceed to conduct the lesson on duration of time.

Introduction

Let pupils experience how long 16 seconds are using a stopwatch. They should feel the time elapsed in 16 seconds. Explain that 60 seconds is equivalent to a minute.

Problem Solving

Explain to pupils that to get the ending time, they should first add the hours to the starting time, and then add the minutes. If the minutes add up to more than 60, convert 60 minutes to 1 hour and add to the starting time, then add the remaining minutes. Suggest ways to calculate the duration of time. For example, in Let's Learn 3 (Textbook 4 P259), to find the duration from 11 55 to 12 25, we can find the duration from 12 00 to 12 25 first, which gives 25 minutes, and then add the 5 minutes (between 11 55 and 12 00) to the 25 minutes to give 30 minutes. Similarly, to calculate the starting time, ask pupils to subtract the hours first and then subtract the remaining minutes if there are. Emphasise the times in 24-hour clock notation while solving all questions.

Activities

Encourage group work when solving questions in the Textbook and Workbook.

Resources

- stopwatch
- geared clock

Mathematical Communication Support

Verbalise all questions using times in 24-hour clock and 12-hour clock.

SOLVING WORD PROBLEMS

LEARNING OBJECTIVE

1. Solve word problems involving time in 24-hour clock.

SOLVING WORD PROBLEMS

LESSON
3

IN FOCUS



Siti took 25 minutes to finish her breakfast. She spent another 1 hr 20 min watching television. She then left the house at 10 45. What time did Siti start eating breakfast?

LET'S LEARN

1.

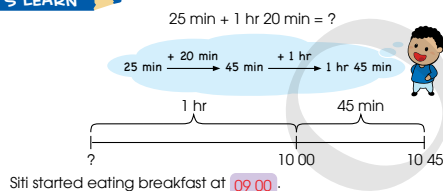

2.

Bina and Priya arrived at the shopping mall at 10 10. They spent 1 hr 45 min shopping before going for lunch. They finished their lunch at 13 15.

- (a) What time did Bina and Priya go for lunch?
- (b) How long did they take to finish lunch?

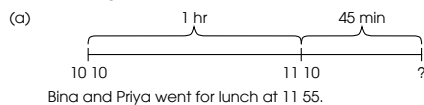

OXFORD
UNIVERSITY PRESS

TIME 262

IN FOCUS

Allow pupils to read the problem silently and highlight important elements. Then discuss with the pupils how the problem can be solved.

LET'S LEARN

Guide pupils to see the sequence of events before Siti left the house and the duration of each event. Then illustrate the solution using the timeline.

Work through Let's Learn 2 with the pupils to find (a) the end time and (b) the duration.

Textbook 4 P262

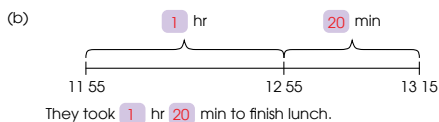

3. Sam and his family took a coach from Singapore to Ipoh. The coach left Singapore at 22 30 on Friday. When they got to Ipoh, they took another 35 min to travel to their hotel and arrived at the hotel at 06 50 on Saturday. How long did the coach ride take?

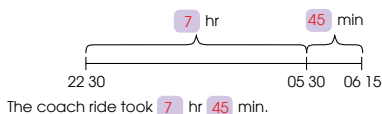
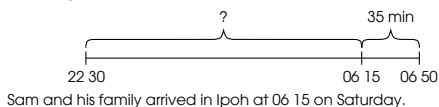

4. A train takes 6 hr 45 min to travel from Town A to Town B. The train left Town A at 23 25, but it was delayed by 30 minutes. When did the train reach Town B?

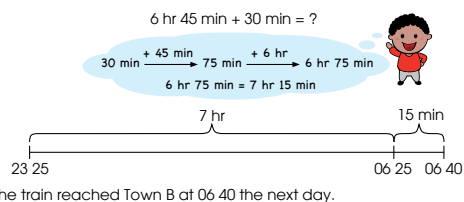

Textbook 4 P263

Work through Let's Learn 3 with the pupils. The first timeline illustrates the timings and the durations of the sequence of events given in the question. The second timeline isolates the required elements to solve for the duration.

Recap the conversion of hours and minutes to minutes and vice versa before working through Let's Learn 4 with the pupils. Highlight the crossing over to the next day.

Work in groups of 3 to 4.

- 1 The table shows information on various flights from Singapore to other countries.

Country	Departure time	Arrival time
Hong Kong	23 45	03 30
Perth	02 55	08 10
Shanghai	08 50	14 00
Kuala Lumpur	19 45	20 50
Taipei	19 35	00 15

- 2 Create three word problems using the information.

- 3 Exchange your word problems with other groups to solve. Solve the word problems.

Use a timeline to help you solve the word problems.

PRACTICE

Solve.

- Nora went to the park to exercise. She cycled for 1 hr 30 min and ran for another 55 minutes. It was 12 15 when she finished her exercise. What time did she start to exercise? 09 50
- Farhan and his family started waiting for the train at 09 15. They waited for 35 minutes and boarded the train.
 - What time did Farhan and his family board the train? 09 50
 - They reached the next town at 19 55.
 - 09 50
 - 10 hr 5 min
- Meiling boarded a plane from Beijing at 23 40. When she reached Singapore, she spent another 1 hr 45 min at the airport and left the airport at 07 35. What was the duration of the flight? 6 hr 10 min

Complete Worksheet 3 • Pages 120 – 123

Textbook 4 P264

ACTIVITY TIME

The activity allows pupils to work in groups to create word problems using information from the table for other groups to solve. Remind pupils to use the timeline.

PRACTICE

Work with pupils on the practice questions.

For better understanding, select items from **Worksheet 3** and work these out with the pupils.

Independent seatwork

Assign pupils to complete Worksheet 3 (Workbook 4B P120 – 123).

1.

 16 45 17 45 18 15

 The train reached Town B at 18 15.

2.

 20 00 03 00 03 30

 The duration of the party was 7 hr 30 min.

3.

 23 50 00 50 01 35

 The football match was 1 hr 45 min long.

4. (a) $2 \text{ hr } 30 \text{ min} + 55 \text{ min} = 3 \text{ hr } 25 \text{ min}$
 She spent 3 hr 25 min on both activities.

- (b)

 13 15 13 40 16 40

 Her piano lesson started at 13 15.

5. (a) $2 \text{ hr } 35 \text{ min} + 2 \text{ hr } 15 \text{ min} = 4 \text{ hr } 50 \text{ min}$
 He spent a total of 4 hr 50 min to paint the rooms.

- (b)

 13 10 17 10 18 00

 He stopped painting at 18 00.

6.

 21 20 23 20 05 20 05 35

 She arrives at Changi Airport at 21 20.

7.

 22 45 23 40 00 10

 The delay was 30 min long.

PROBLEM SOLVING, MATHS JOURNAL AND PUPIL REVIEW

MIND WORKOUT

After every hour, Weiming's watch slows down by 2 minutes and Tom's watch gets faster by 1 minute. They both set their watches at 6.00 a.m. After the first hour, their watches showed the following times.



Weiming



Tom

Use a timeline to help you.



What is the actual time when the times shown on their watches are 15 minutes apart? **Ans: 11 00**

MATHS JOURNAL

Priya would like to spend 3 hours in Sentosa visiting four different attractions. Use the schedule below to suggest a plan where Priya can visit all four attractions in 3 hours.

Crane Dance	Images of Singapore	Lake of Dreams	An Hour in 4D Show
First show: 19 00 Last show: 22 00 Show runs every 30 minutes	Open from 10 00 to 19 30	21 30 daily Show lasts for 20 minutes	Show Times 11 00 14 00 17 00 19 00 21 00

I know how to...

- tell time to the second.
- read time using the 24-hour clock.
- find the duration, starting time and finishing time.
- solve word problems on time.

265 CHAPTER 12

OXFORD
UNIVERSITY PRESS

Textbook 4 P265



MIND WORKOUT

A non-routine problem which requires pupils to 'Make a List' which they have encountered earlier in Chapter 2 textbook (P56) and workbook (P51). To facilitate, guide pupils to set up and fill in the table:

Time	Weiming's watch	Tom's watch	Difference
06 00	06 00	06 00	0 min
07 00	06 58	07 01	3 min
08 00	07 56	08 02	6 min
09 00			

7. A ferry was scheduled to depart from Hong Kong to Macau at 22 45. However, there was a delay and it reached Macau at 00 10. The ferry took 55 minutes to travel from Hong Kong to Macau. How long was the delay?



The delay was 30 min long.



Mind Workout

Date: _____

Bina and her family flew from Singapore to Tokyo. Their flight departed from Singapore at 21 00 on 12 May. The duration of their flight was 7 hours. The time in Tokyo when they arrived was 05 00 on 13 May. What is the time difference between Singapore and Tokyo?

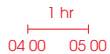
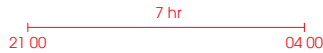

The time difference between Singapore and Tokyo is 1 hr.

OXFORD UNIVERSITY PRESS

Time 123



Mind Workout

To facilitate, ask pupils:
At what time did the plane arrive in Tokyo using Singapore time?
What is the difference in the arrival time using Singapore time and Tokyo time?

Workbook 4B P123



MIND WORKOUT

After every hour, Weiming's watch slows down by 2 minutes and Tom's watch gets faster by 1 minute. They both set their watches at 6.00 a.m. After the first hour, their watches showed the following times.



Weiming



Tom

Use a timeline to help you.





What is the actual time when the times shown on their watches are 15 minutes apart? **Ans: 11 00**

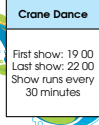

MATHS JOURNAL

Priya would like to spend 3 hours in Sentosa visiting four different attractions. Use the schedule below to suggest a plan where Priya can visit all four attractions in 3 hours.

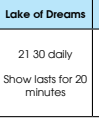
Crane Dance	Images of Singapore	Lake of Dreams	An Hour in 4D Show
 First show: 19 00 Last show: 22 00 Show runs every 30 minutes	 Open from 10 00 to 19 30	 21 30 daily Show lasts for 20 minutes	 Show Times 11 00 14 00 17 00 19 00 21 00

I know how to...

- tell time to the second.
- read time using the 24-hour clock.
- find the duration, starting time and finishing time.
- solve word problems on time.

SELF-CHECK



265

CHAPTER 12

OXFORD UNIVERSITY PRESS



MATHS JOURNAL

To facilitate the activity, help pupils make sense of the schedule of the different attractions. Show an example of how Priya can plan her visit.

Before the pupils do the self-check, review the important concepts once more by asking for examples learnt for each objective.

This self-check can be done after pupils have completed **Review 12** (Workbook 4B P124 – 127).

SELF-CHECK



Textbook 4 P265

1.

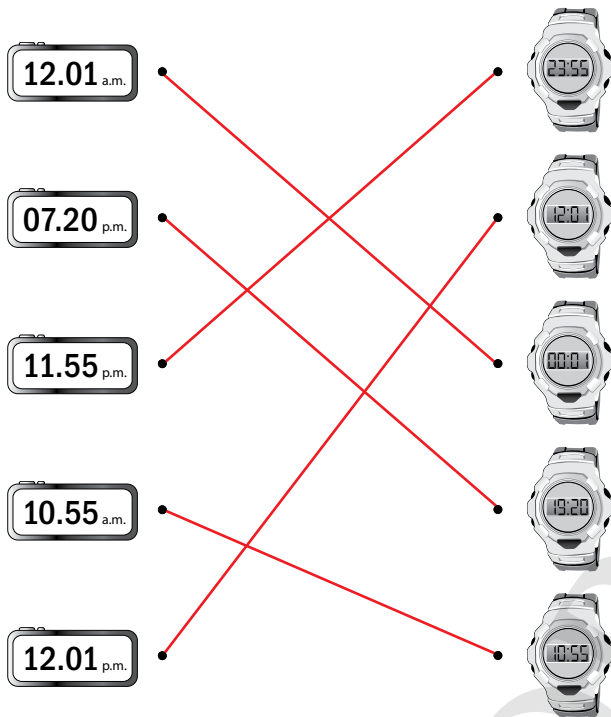

5.

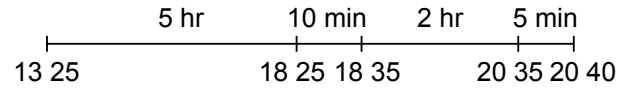

He spent 2 hr 5 min having his dinner.

*6.

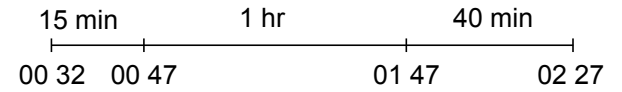

They arrived at the supermarket at 00 32.

2. (a)

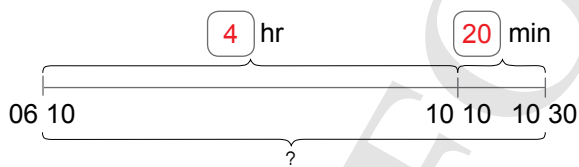

The flight duration was 4 hr 20 min.

(b)

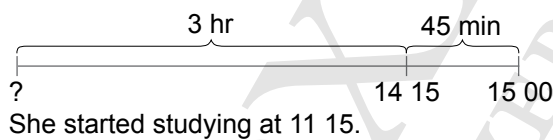

She started studying at 11 15.

(c)

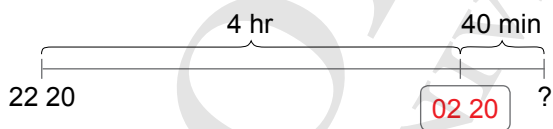

The movie marathon ended at 03 00.

3. (a)

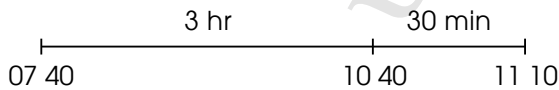

The duration of the test was 3 hr 30 min.

(b)

$3 \text{ hr } 30 \text{ min} - 45 \text{ min} = 2 \text{ hr } 45 \text{ min}$
Farhan took 2 hr 45 min to finish the test.

4.

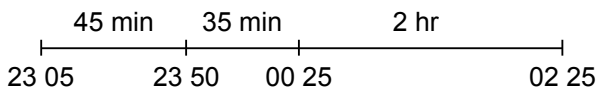

(a) The movie started at 23 50.

(b) 23 05

1. $20 \div 4 = 5$
The length of the square is 5 cm.
2. $12 \div 2 = 6$
The length of the rectangle is 6 cm.
3. (a) $8 \times 8 = 64$
Length \rightarrow 8 cm
Perimeter $\rightarrow 8 \text{ cm} \times 4 = 32 \text{ cm}$
(b) $48 \text{ cm} - 9 \text{ cm} - 9 \text{ cm} = 30 \text{ cm}$
Length $\rightarrow 30 \text{ cm} \div 2 = 15 \text{ cm}$
Area $\rightarrow 15 \text{ cm} \times 9 \text{ cm} = 135 \text{ cm}^2$
4. (a) $5 \text{ m} \times 4 \text{ m} = 20 \text{ m}^2$
The area of the floor is 20 m^2 .
(b) $5 \text{ m} - 1 \text{ m} = 4 \text{ m}$
 $4 \text{ m} - 3 \text{ m} = 1 \text{ m}$
 $4 \text{ m} \times 1 \text{ m} = 4 \text{ m}^2$
The area of the floor covered by the carpet is 4 m^2 .
(c) $20 \text{ m}^2 - 4 \text{ m}^2 = 16 \text{ m}^2$
The area of the floor not covered by the carpet is 16 m^2 .
5. $7 \text{ cm} \times 7 \text{ cm} = 49 \text{ cm}^2$
Area $\rightarrow 49 \text{ cm}^2 \times 3 = 147 \text{ cm}^2$
Perimeter $\rightarrow 7 \text{ cm} \times 8 = 56 \text{ cm}$
6. Perimeter
 $25 \text{ cm} + 21 \text{ cm} + 25 \text{ cm} + 21 \text{ cm} + 9 \text{ cm} + 9 \text{ cm}$
 $= 110 \text{ cm}$
Area
 $25 \text{ cm} - 9 \text{ cm} - 9 \text{ cm} = 7 \text{ cm}$
 $9 \text{ cm} \times 7 \text{ cm} = 63 \text{ cm}^2$
 $25 \text{ cm} \times 21 \text{ cm} = 525 \text{ cm}^2$
 $525 \text{ cm}^2 - 63 \text{ cm}^2 = 462 \text{ cm}^2$
7. $8 \text{ cm} \times 4 = 32 \text{ cm}$
 $32 \text{ cm} - 4 \text{ cm} - 4 \text{ cm} = 24 \text{ cm}$
 $24 \text{ cm} \div 2 = 12 \text{ cm}$
The length of the rectangle is 12 cm.
8. $125 \text{ cm} \times 60 \text{ cm} = 7500 \text{ cm}^2$
 $30 \text{ cm} \times 20 \text{ cm} = 600 \text{ cm}^2$
 $7500 \text{ cm}^2 - 600 \text{ cm}^2 = 6900 \text{ cm}^2$
The area of the table top not covered by the table mat is 6900 cm^2 .

9. (a)

Type of Food	Number of Pupils
Chicken wing	3
Noodles	6
Burger	7
Roti prata	2
Cake	5
Others	4

- (b) 4
(c) 4
(d) 8
10. (a) 40
(b) April
(c) 15
(d) 40

1. (a) 12
 (b) 19
 (c) 16
 (d) 35

2. (a) August, September
 (b) 150 mm
 (c) 1175 mm

3. (a) Friday, Saturday
 (b) 8
 (c) Ann received her allowance on Monday.

4.

12-hour clock	24-hour clock
7.50 a.m.	07 50
12.54 p.m.	12 54
3.15 p.m.	15 15
8.57 p.m.	20 57
12.09 a.m.	00 09
2.20 a.m.	02 20

5.

24-hour clock	12-hour clock
08 10	8.10 a.m.
20 45	8.45 p.m.
00 34	12.34 a.m.
15 35	3.35 p.m.
12 07	12.07 a.m.
10 05	10.05 a.m.

6. $30\text{ cm} - 8\text{ cm} = 22\text{ cm}$
 Area $\rightarrow 30\text{ cm} \times 22\text{ cm} = 660\text{ cm}^2$
 Perimeter $\rightarrow 30\text{ cm} + 22\text{ cm} + 30\text{ cm} + 22\text{ cm}$
 $= 104\text{ cm}$

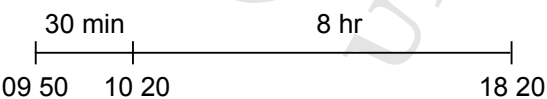
7. (a) 
 He starts work at 09 50.

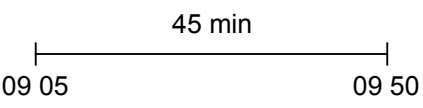
- (b) 
 The latest time he must start travelling to work is 09 50.

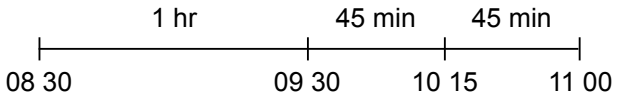
8. 
 They left the beach at 11 00.

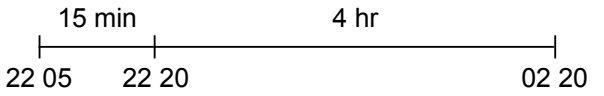
9. 
 The plane departed from Singapore at 22 05.

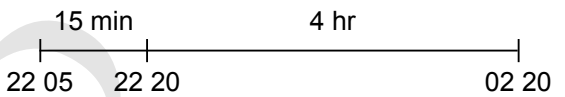
10. 
 It would have taken 5 hr 50 min to reach Ipoh.

1. 4
2. 1
3. 3
4. 2
5. 1
6. 2
7. 2
8. 3
9. 4
10. 1
11. 4
12. 1
13. 2
14. 3
15. 2
16. Forty thousand, three hundred and five
17. $\frac{3}{50}$
18. $2\frac{5}{6}$ hr
19. $40 \div 5 = 8$
 $8 \times 3 = 24$
20. 1, 2, 3, 4, 6, 8, 12, 24
21. 0.07
22. 1.44 m
23. 8892
24. $\$95.55 \div 7 = \13.65
25. (a) 02 30
(b) 1.45 p.m.
26. 3 hr + 5 hr 30 min = 8 hr 30 min
27. 6 cm
28. $12 \div 3 = 4$
 $35 \div 7 = 5$
 $4 \times 5 = 20$
29. $20 + 5 + 3 = 28$
 $28 + 5 + 28 + 5 = 66$
30. $8 + 5 + 8 + 5 = 26$
31. (a) 250
(b) 350
32. (a) $30 + 24 = 54$
(b) $9 \times 3 = 27$
33. 135°
34. 20 05
- *35. $3 + 1 = 4$
 $24 \div 4 = 6$
 $6 \times \$2.60 = \15.60
Mrs Tan needs to pay \$15.60 for 24 apples.
36. $485 - 30 = 455$
 $455 \div 5 = 91$
 $91 \times 2 = 182$
Tom received 182 cards.
37. $9106 - 3894 = 5212$
 $5212 \div 2 = 2606$
 $2606 + 3894 = 6500$
The greater number is 6500.

$$38. \frac{4}{5} - \frac{1}{3} = \frac{7}{15}$$

$$\frac{4}{5} \div \frac{7}{15} = 1\frac{4}{15}$$

Meiling and Raju ate $1\frac{4}{15}$ tarts altogether.

$$39. 36 \div 3 = 12$$

$$12 \times 8 = 96$$

There are 96 balls in the box.

$$40. 21.6 \ell - 3.3 \ell = 18.3 \ell$$

$$18.3 \ell \div 4 = 4.575 \ell$$

$$\approx 4.6 \ell$$

The capacity of each pail is 4.6 ℓ.

$$41. \$19.90 \times 4 = \$79.60$$

$$\$82.95 - \$79.60 = \$3.35$$

The pair of socks cost \$3.35.

$$42. \$11.70 - \$1.30 = \$10.40$$

$$\$10.40 \div 4 = \$2.60$$

One bag of lemons cost \$2.60.

$$43. 25 \text{ cm} \times 18 \text{ cm} = 450 \text{ cm}^2$$

$$23 \text{ cm} \times 16 \text{ cm} = 368 \text{ cm}^2$$

$$450 \text{ cm}^2 - 368 \text{ cm}^2 = 82 \text{ cm}^2$$

The area of the board that will not be covered by paper is 82 cm².

$$44. 1050 - 314 = 736$$

$$736 \div 4 = 184$$

$$184 \times 5 = 920$$

Kate had 920 beads at first.

$$*45. \$2.75 + \$2.15 = \$4.90$$

$$\$4.90 \div 2 = \$2.45$$

Each bottle of milk cost \$2.45.

NAVIGATING THROUGH THE ASSESSMENT EXERCISES AND ACTIVITIES

For teachers to assess pupils' achievement of the learning objectives, the Teacher's Resource Book provides direction for teachers on how to use the following assessment and exercises. Summarising the evaluative aspect of this series, the following exercises can be utilised optimally.

TEXTBOOK

CHAPTER OPENER

Chapter Opener consists of familiar events or occurrences that serve as an introduction of the topic to pupils.

IN FOCUS

Questions related to the lesson objectives are asked as an introductory activity for pupils. The activity allows pupils to explore different ways to solve the problem.

LET'S LEARN

Main concepts are introduced in Let's Learn. The consolidation and formalising of concepts are achieved. The exercises can be used by teachers to test their pupils' prior knowledge. Teachers can provide valuable assessment-based feedback to pupils. Having pupils attempt these exercises will help teachers identify the focus of each lesson and the adjustments they need to make to their teaching in order to help pupils meet the intended learning outcomes.

ACTIVITY TIME

Most of the activities in the book are to be carried out in pairs or groups. Pupils explore mathematical concepts in a fun way through games. Observing pupils' approach and dexterity while doing the activity will give a clear indication to teachers on how the lesson should be conducted.

PRACTICE

The questions in Practice enable teachers to gauge if pupils have grasped the concepts. Practice can be done as an independent exercise in class or as homework.

Through the questions, teachers get to understand what their pupils have learned. They will be able to find the answers to the following questions:

- Are there any common gaps in my pupils' knowledge of the topic which I need to revisit?
- In which aspects of my pupils' learning of the topic did they achieve mastery?
- What are the strengths and weaknesses in my planning for teaching?



MIND WORKOUT

Pupils' critical and problem-solving skills are enhanced when working on the Mind Workout. Teachers can use the exercises to challenge advanced learners. It is advisable to use the exercise as an independent assignment for pupils.

MATHS JOURNAL

Maths Journal enhances pupils' skills such as mathematical communication, reasoning, organisation and tabulation of data. The exercises can be done in a group or individually in class or at home.

SELF-CHECK

Key concepts required in the syllabus that must be learnt are highlighted in Self-Check. It would be beneficial for pupils when teachers revise the key concepts in class as this allows pupils to assess their own learning at the end of each chapter and facilitates their revision in preparation for the examination.

Worksheets

Well-structured questions covering all the concepts taught in each lesson, are found in each worksheet. A suggested approach would be to have pupils do alternate questions from each worksheet or do the questions that will build their foundation of the concepts. The skipped questions can be revisited during revision before the examination. The worksheets in the workbooks can be done as a complimentary practice exercise to augment the concepts learnt.



Maths Journal

Maths Journal tests pupils' understanding of the mathematical concepts learnt in the chapter and further enhances their learning of the concepts.



Mind Workout

Mind Workout consists of higher-order thinking tasks which enable pupils to apply relevant heuristics and extend the concepts and skills learnt.

Revision

Revision exercises at the end of a set of chapters consist of questions that enable pupils to apply all the concepts and skills taught. The exercises can be done before an examination or a test. They serve as good revision exercises for pupils to do in class or as homework with guidance from their parents when necessary. They also enable teachers to evaluate the pupils' understanding of the concepts across strands and topics and can be used as an effective preparatory exercise for examinations.

Review

The Review Exercise consists of questions that requires the application of a consolidation of concepts learnt in the chapter. The exercises can be done as a group assignment for teachers to gauge the pupils' ability to grasp the consolidated concepts learnt in the chapter. Group assignments help pupils to learn together as they gather feedback from one another. Teachers can also get pupils to submit their completed exercises and mark them as a form of informal assessment.

Mid-Year and End-of-Year Revisions

These are assessment exercises with multiple choice questions, short-answer questions and word problems. Teachers can use the revision exercises as mock examinations to help pupils prepare for the examinations. Feedback provided to pupils will be extremely beneficial as they will be aware of the areas that they are weak in and work on them. The revision exercises test pupils' ability to recall the concepts taught and apply them. They also allow teachers to analyse the effectiveness of their spiral approach of teaching concepts. Teaching concepts by revisiting, re-linking to other concepts and creating a mind map help pupils do their examinations in a more effective way. A good evaluative assessment should not consist of questions that encourage rote learning, but should consist of questions that encourage learning by the spiral approach.

Examination papers should not be considered by teachers as the only means of evaluation. Informal evaluation involves classroom discussions, participation, exchange of ideas, multiple strategies, activities, group assignments, presentations and above all, mind-mapping, before they embark on independent work. It is essential for the pupils to receive feedback on their work which provides an important opportunity for reflection on what they have learnt. Similarly, teachers should be able to diagnose the progress and achievement of the pupils and decide on the future course of action, which is where the assessment activities and exercises come in.

